

Step-down rectifier makes a simple dc power supply

NATHAN OSOKA, DESIGN AUTOMATION INC, KK IT SUM, CONSULTANT, AND
DAVID CHAMIL, SURREY SPACE CENTRE

Most equipment operating from the ac power mains needs low-voltage dc. Traditionally the power supply comprises a 50/60-Hz step-down transformer followed by a rectifier, or it comprises a switch-mode power supply (SMPS) that consists of a rectifier followed by a step-down dc/dc converter. Both types can easily include isolation.

However, electrical isolation of the internal circuitry is unnecessary for many applications. Low-power equipment without user inputs or outputs can use double-insulated enclosures to comply with electrical-safety requirements. Examples include clocks, certain battery chargers, TV receivers, and auxiliary supplies for the primary-side control circuits of SMPSs. At higher power levels—in motor drives, for example—all the equipment, including the output, may be live. For these applications, you get little benefit from having an isolated auxiliary supply and it is advantageous

A simple and useful nonisolated rectifier features voltage step-down operation, acceptable Class A line-current harmonics, inherent short-circuit protection, and, optionally, a regulated output.

to use a small, lightweight, low-cost power supply with few components, such as the simple rectifier in [Figure 1](#).

Direct rectification normally gives a voltage approaching the peak value of the mains voltage, but placing an impedance in series with the ac input reduces the dc output voltage. If the

impedance is resistive, low efficiency results. However if the impedance is reactive, the circuit is essentially lossless, except for diode losses and a small power loss in the parasitic series resistance.

Using either a capacitor or an inductor reduces the line-current harmonics to lower than those of a circuit without the series reactance. The choice between an inductor and a capacitor depends on their relative size, cost, parasitic losses, and availability. An inductor can attenuate spikes that might be on the ac input voltage but can also cause overshoot on the dc output voltage at turn-on. This overshoot results from a resonance between the series inductor and the output reservoir capacitor, especially at light loads. In general, low-power applications favor the capacitor and high-power applications favor the inductor.

The rectifier in [Figure 1](#), a capacitor-fed version, is not new. Commercial battery chargers have used the circuit since at least the 1970s. However, few people know about or understand the circuit. Published information regarding this rectifier exists in brief descriptions in manufacturers' applications notes and a handbook ([References 1 through 3](#)). An encyclopedic compendium of rectifiers does not even list the exact circuit, although it does show a similar circuit ([Reference 4](#)). Considering IEC 1000-3-2 ([Reference 5](#)) and similar regulations, it is currently necessary to investigate the rectifier's line-current harmonic characteristics.

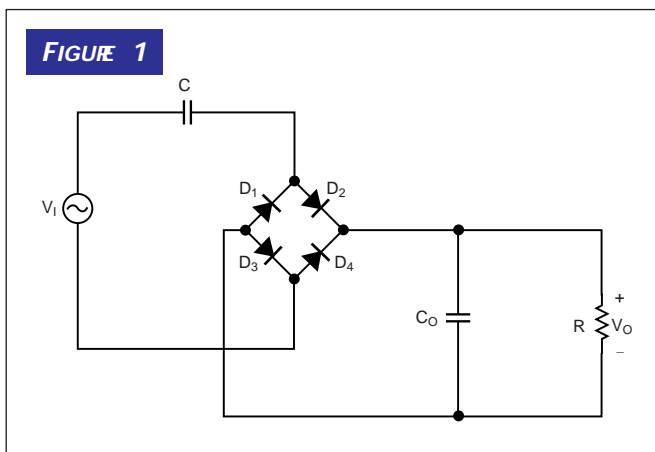

A simple capacitor-fed rectifier uses a large reservoir capacitor, C_0 , to keep the output voltage, V_0 , nearly constant throughout the operating cycle.

Analyze the circuit

Despite the apparent simplicity of the circuit, the details of its operation are not obvious. (This article is an abridged version of an IEEE conference paper, and [Reference 6](#) con-

SIMPLE STEP-DOWN, NONISOLATED RECTIFIER

tains a more detailed analysis.) The operational cycle comprises four time intervals (**Figure 2**). The large reservoir capacitor, C_o , keeps the output voltage, V_o , nearly constant throughout the cycle. You can initially assume that C_o is infinite and later apply a ripple correction for C_o 's finite capacitance. The mean (dc) output current, I_o , is

$$I_o = \frac{\omega}{\pi} \int_{t_2}^{t_4} i_1(t) dt = 4fC(\sqrt{2}V_1 - V_o - V_D), \quad (1)$$

where i_1 is the line current, V_1 is the rms ac input voltage (assumedly sinusoidal), V_o is the dc output voltage with infinite C_o , and V_D is the forward-conducting voltage of one diode.

Let the magnitude of the capacitive reactance at ω be

$$X \triangleq \left| \frac{-1}{\omega C} \right| = \frac{1}{\omega C}. \quad (2)$$

(Capacitive reactance is actually negative, so keep in mind that the notation "X" is for convenience, and $X=|X|$.)

Using **Equation 1** and the fact that $V_o = I_o R$, the rectifier's dc output voltage is

$$V_o = \frac{2R}{\pi X} \cdot \frac{\sqrt{2}V_1 - V_D}{1 + \frac{2R}{\pi X}}. \quad (3)$$

The output voltage depends on the amount of capacitive reactance present, normalized with respect to the load resistance. In other words, X/R is the main design parameter.

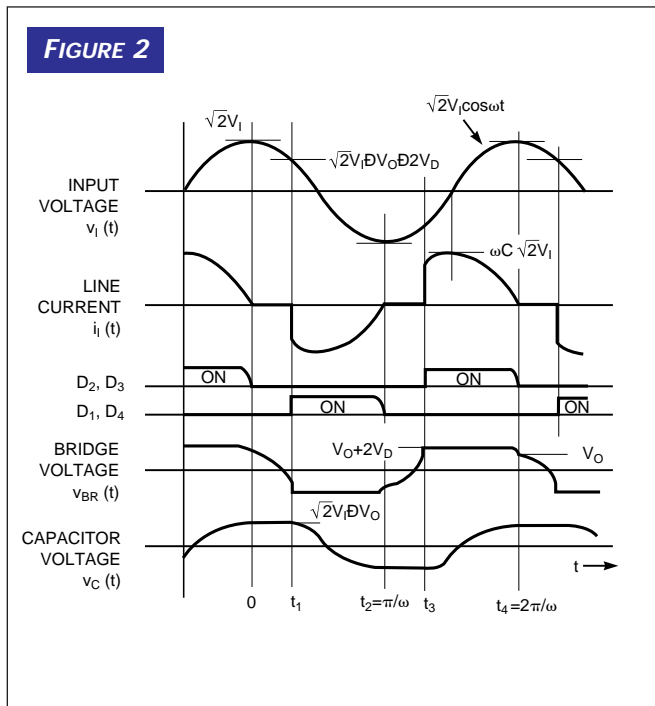

The rectifier's principal steady-state waveforms indicate four distinct operational regions: 0 to t_1 , t_1 to t_2 , t_2 to t_3 , and t_3 to t_4 .

With $X/R \ll 1$, the output voltage approaches the peak value of the input voltage, as expected. When $X/R \gg 1$, the output voltage is low. You can rearrange **Equation 3** into

$$X = \frac{2R}{\pi} \cdot \frac{\sqrt{2}V_1 - V_o - V_D}{V_o}. \quad (4)$$

Assuming that $V_D \ll V_1$, a dimensionless plot of X/R vs V_1/V_o is useful for design purposes (**Figure 3**).

Rearranging **Equation 1** gives the dc output characteristic for the case when $I_o > 0$:

$$V_o = \sqrt{2}V_1 - V_D - \frac{I_o}{4fC}. \quad (5)$$

Thus, you can represent the rectifier by a Thevenin-equivalent circuit comprising a voltage source of $\sqrt{2}V_1 - V_D$ in series with a resistance of $1/4fC$. This resistance is lossless because it is due to capacitive reactance on the ac side of the rectifier.

Then, by setting $I_o = 0$ in **Equation 5**, you find the open-circuit voltage:

$$V_{O(OPEN)} = \sqrt{2}V_1. \quad (6)$$

On the other hand, setting $V_o = 0$ yields the short-circuit output current:

$$I_{O(SHORT)} = \sqrt{32}fCV_1. \quad (7)$$

Thus, the rectifier has the useful feature of inherent overload protection. The rectifier now appears to the ac supply as a simple capacitive reactance, and the rms line current is

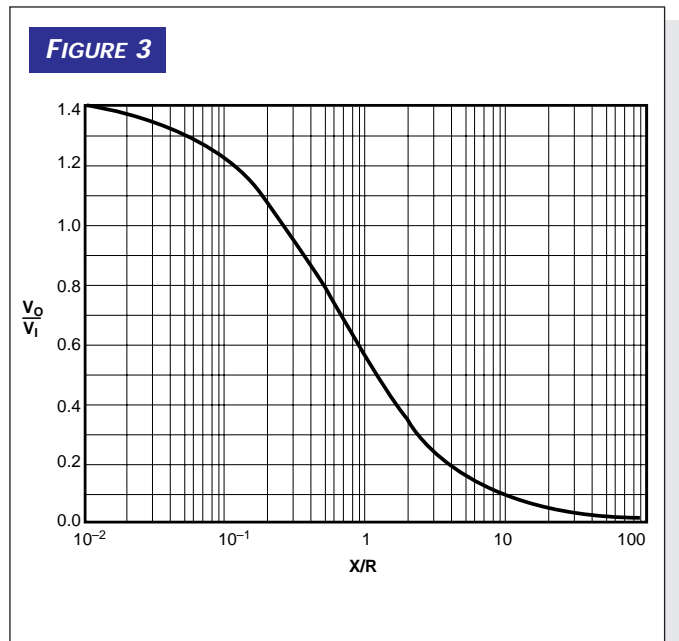

Plotting X/R as a function of V_o/V_1 , with $V_D = 0$, shows that increasing the series capacitive reactance reduces the output voltage.

SIMPLE STEP-DOWN, NONISOLATED RECTIFIER

$$I_{I(\text{SHORT})} = 2\pi f C V_1 \quad (8)$$

If $V_o \ll V_1$, the rectifier approximates a dc current source, which makes the circuit useful for applications such as constant-current charging of NiCd batteries, in which case the battery replaces C_o and R (Reference 1).

Correct for finite C_o

The actual output voltage is lower than the value predicted using $C_o = \infty$, because of the presence of ripple. Assuming that the ac ripple waveform is symmetrical about the mean output voltage level, you can multiply V_o by a ripple correction as follows:

$$V_{O(\text{CORRECTED})} = V_o(1 - r/2), \quad (9)$$

where the ripple factor, r , is defined in terms of ΔV_o , the peak-to-peak output voltage ripple:

$$r = \frac{\Delta V_o}{V_{O(\text{CORRECTED})}} \quad (10)$$

A reasonable assumption is that the ripple and thus the ripple factor, r , should be inversely proportional to f , C_o , and R , at least to a first approximation. In reality, r also varies with X/R because the conduction angle of the diodes changes. Taking this approach, you can use Equation 11 to estimate the value of r :

$$r \approx \frac{0.24 - 0.10 \log_{10}(X/R)}{f C_o R} \quad (11)$$

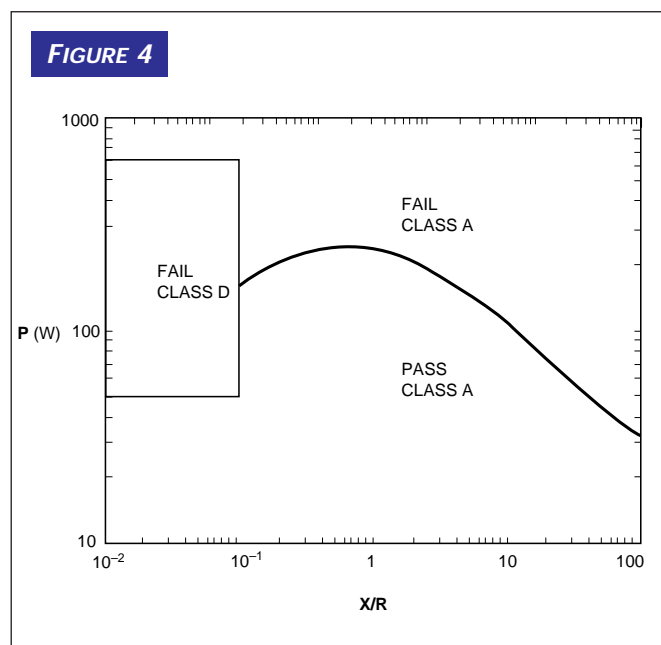

The rectifier complies with Class A requirements over a useful range of power. Maximum power, P , of 250W is available when $X/R \approx 0.5$.

This equation results from a combination of performing analysis and fitting a function to values of r obtained by PSpice simulation, with X/R in the 512-to-1 range of $0.03125 \leq X/R \leq 16$.

Simulation results verify operation

A series of PSpice simulations to verify the analysis uses the parameter values of $V_1 = 120V$ rms, $f = 60$ Hz, $R = 100\Omega$, and $C_o = 1$ mF. The value of C varies among runs. The simulation uses the default Spice model for each diode with a series resistance set to 0.5Ω . Table 1 compares the steady-state output voltage with the theoretical predictions obtained from Equation 3 using $V_D = 0.8V$ and the ripple correction of Equations 9 and 11.

The theoretical and simulation results agree to better than $\pm 2\%$ over the 512-to-1 range of X/R . The discrepancy is greatest at low X/R , for which the circuit's performance approaches that of a conventional rectifier. The reason for this discrepancy is that the input current has a spiky waveform that causes a significant voltage across the diodes' ohmic series resistance, but the theoretical analysis doesn't consider this voltage. However, this result is of little consequence because the rectifier mainly targets step-down applications, for which X/R is high.

The design steps for the rectifier are as follows:

1. Represent the dc load as an equivalent resistance,

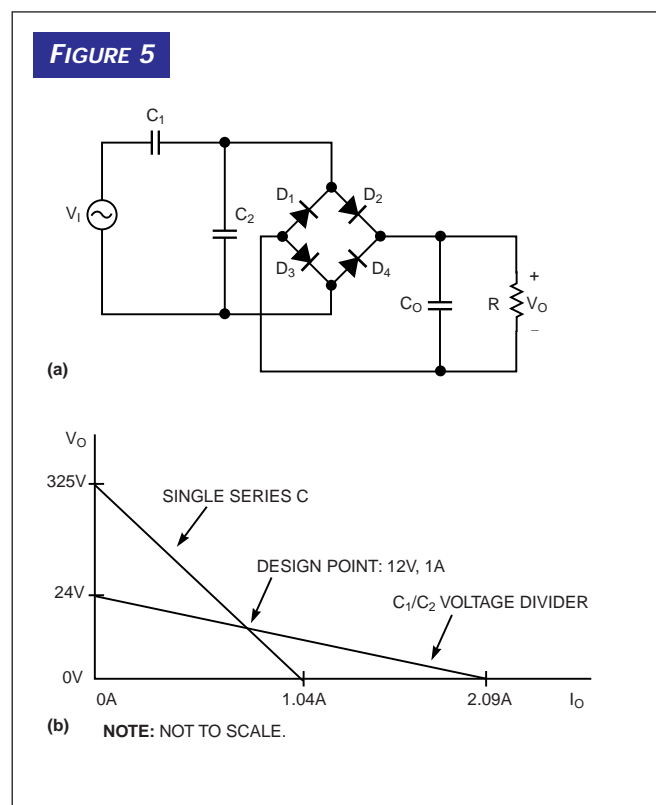

A capacitive voltage divider comprising C_1 and C_2 reduces the no-load output voltage (a) and substantially improves the load regulation of the original circuit (b).

SIMPLE STEP-DOWN, NONISOLATED RECTIFIER

$R = V_{O(\text{CORRECTED})} / I_O$, where $V_{O(\text{CORRECTED})}$ is the desired dc output voltage.

- Define a desired ripple factor, r , from [Equation 10](#).
- Find the infinite- C_O output voltage using a rearranged [Equation 9](#): $V_O = V_{O(\text{CORRECTED})} / (1-r/2)$.
- Use [Equation 4](#) to find X . Or, for a less accurate result, obtain X/R from [Figure 3](#), and multiply by R . Then calculate $C = 1/2\pi fX$.
- Use [Equation 11](#) to calculate the necessary output smoothing capacitance, C_O .
- Find the short-circuit output current from [Equation 7](#).

You can follow these steps to find component values for a real rectifier. Consider a design with the following parameters: $V_I = 230\text{V}$, $f = 50\text{ Hz}$, and $V_{O(\text{CORRECTED})} = 12\text{V}$ with $0.5\text{V}_{\text{p-p}}$ ripple superimposed at $I_O = 1\text{A}$. Then, perform the following calculations:

- DC load resistance $R = 12\text{V}/1\text{A} = 12\Omega$.
- Ripple factor $r \approx 0.5\text{V}/12\text{V} = 0.042$.
- Infinite- C_O output voltage $V_O = 12\text{V}/(1-0.042/2) = 12.26\text{V}$.
- A suitable diode bridge has $V_D = 0.85\text{V}$. Then,

$$X = \frac{2 \cdot 12.26}{\pi} \cdot \frac{\sqrt{2} \cdot 230 - 12.26 - 0.85}{12.26} = 199\Omega \quad (12)$$

(Note that in [Equation 12](#) and subsequent calculations, R now equals 12.26. Increasing R from 12 to 12.26 is necessary to maintain the specified load current of 1A.) Now, $C = 1/(2\pi \times 50 \times 199) = 16.0\ \mu\text{F}$.

- The output capacitance is

$$C_O = \frac{0.24 - 0.10 \log_{10}(199/12.26)}{50 \cdot 12.26 \cdot 0.042} = 4.62\ \text{mF} \quad (13)$$

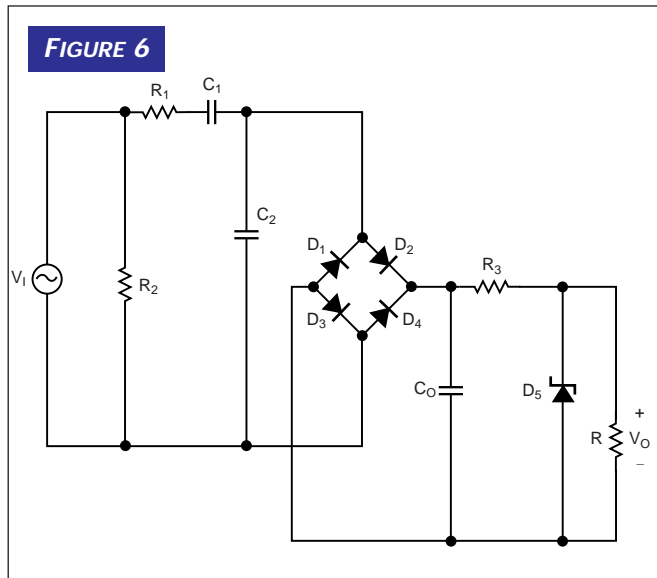

In addition to the C_1/C_2 voltage divider, which provides over-voltage protection, a shunt regulator comprising R_3 and D_5 further improves the basic circuit by stabilizing the output voltage.

- The short-circuit output current is $\sqrt{32} \times 230 \times 50 \times 16.0 \times 10^{-6} = 1.04\text{A}$. This number is only 4% higher than the nominal current in normal operation.

Confirm the design

The design was constructed with measured values of $C = 15.75\ \mu\text{F}$ (nominally two $8\text{-}\mu\text{F}$ 440V-ac, metallized polypropylene-film capacitors), $V_D = 0.85\text{V}$ at 1A dc (GBPC106 diode bridge: 600V, 2A), and $C_O = 5.83\ \text{mF}$ (nominally a 4.7-mF , 63V-dc, electrolytic capacitor). During performance measurements, a power amplifier delivered an undistorted 230V, 50-Hz sine wave, and a rheostat acted as the dc load. The design was also analyzed and simulated using the measured values of the circuit parameters. [Table 2](#) compares the three sets of results, which agree over a range of output voltages ($30.00\text{V}/0.11\text{V} = 273\text{-to-1}$).

Study the input-current harmonics

The line-current waveform of the capacitor-fed rectifier is smoother than that of a conventional rectifier, so you might expect the harmonics to be lower. PSpice simulation results show that the larger the value of X/R , the lower the harmonic distortion. This property is valuable because the rectifier is intended for low output voltages.

IEC 555-2 (1987) is the original specification for harmonic-current emissions from electronic equipment, but electromagnetic-compatibility standard IEC 1000-3-2:1995 later subsumed this specification. As EN 61000, this European standard now carries the force of law within Europe. It is important, therefore, to examine this rectifier to see whether it can comply. (The United States does not yet impose comparable regulations on line-current harmonics.)

To analyze the rectifier's harmonic content, assume ideal diodes, $V_D = 0$, and an infinite output capacitance, $C_O = \infty$. The rms input current is then

$$I_1 = I \sqrt{1 - \frac{2\alpha - \sin 2\alpha}{2\pi}} \quad (14)$$

where $I = I_{(\text{SHORT})}$ (see [Equation 8](#)), and $\alpha = \omega t_1$. A detailed analysis and [Equation 3](#) give α as

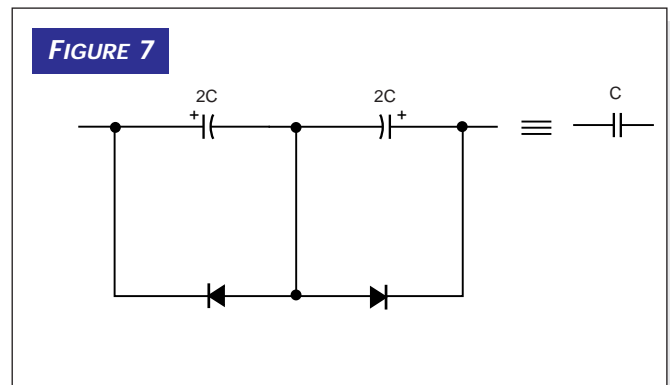

Two back-to-back electrolytic capacitors and two antiparallel diodes can emulate an ac-rated capacitor.

SIMPLE STEP-DOWN, NONISOLATED RECTIFIER

$$\alpha = \cos^{-1} \left(1 - \frac{4R}{\pi X} \cdot \frac{1}{1 + 2R/\pi X} \right) \quad (15)$$

The rms value of the fundamental is

$$I_{I(1)}(\alpha) = \frac{I}{\pi} \sqrt{\frac{1 + 2(\pi - \alpha)^2 + 2(\pi - \alpha)\sin 2\alpha - \cos 2\alpha}{2}} \quad (16)$$

The input current contains only odd harmonics because of the waveform's symmetry. Harmonic currents for $n=3, 5, 7, 9$, and so on are as follows:

$$I_{I(n)}(\alpha) = \frac{2I}{\pi(n^2 - 1)} \sqrt{\frac{1 + n^2 - (n^2 - 1)\cos^2 \alpha}{-2(\cos \alpha \cos n\alpha + n \sin \alpha \sin n\alpha)}} \quad (17)$$

The third harmonic dominates, irrespective of α .

You can now set these results within the context of IEC 1000-3-2. Two classes of equipment are relevant to rectifiers. If a rectifier's active power consumption is 50 to 600W and its line-current waveform fits within a given template, the rectifier belongs to Class D. Otherwise, it belongs to Class A. Different harmonic limits apply for each category, Class D being the stricter. (The 50W lower limit applies from July 1998; before that date, it is 75W.)

For the previous design example, $X/R=199/12=16.6$, so $\alpha=0.387$, and the input current is 1.14A rms. The output power is 12W, so the power factor is approximately $12/(230 \times 1.14)=0.045$. The extremely low power factor is due to the series capacitor, not harmonic currents; the THD is only 9.5%. This rectifier's leading displacement factor ($\cos \phi_1$) can assist in compensating for lagging displacement factors elsewhere.

Rectifier meets Class A, not Class D limits

An in-depth analysis in Reference 6 shows that the circuit always violates Class D limits for any valid combination of output power, P , and X/R . For parameter values for which the rectifier does not fall into Class D, you must evaluate the circuit according to Class A. Fortunately, Class A has absolute, rather than relative, harmonic-current limits, which favor low-power equipment.

For $V_i=230V$ rms and various combinations of P and X/R , comparing calculated odd harmonic currents as high as the 39th harmonic to the published limits shows that the rectifier complies with the Class A requirements over a useful range of power. When $X/R=0.104$, power as high as 65W is available, rising to a maximum of 250W when $X/R \approx 0.5$ ($V_o \approx 180V$) and trailing off again at high values of X/R . Thus, although the rectifier doesn't comply with IEC 1000-3-2, Class D, it does fall into Class A for significant voltage step-down ratios. The circuit then meets IEC 1000-3-2 for power levels as high as 250W, depending on the voltage step-down ratio.

Figure 4 shows the class and pass/fail regions in the X/R - P parameter plane. You can correlate the X/R and P parameters to output current and voltage. For example, to obtain a 5V-dc output from a 230V supply, $X/R=41$. Figure 4 shows

TABLE 1—OUTPUT-VOLTAGE COMPARISON

X/R	Theoretical* (V)	Simulation (V)	Absolute discrepancy (V)	Relative discrepancy (%)
0.03125	155.76	153.12	2.64	1.7
0.0625	149.19	147.50	1.69	1.1
0.125	137.30	137.00	0.30	0.2
0.25	118.25	118.00	0.25	0.2
0.5	92.47	92.95	-0.48	-0.5
1	64.39	65.15	-0.76	-1.2
2	40.07	40.55	-0.48	-1.2
4	22.84	23.12	-0.28	-1.2
8	12.30	12.38	-0.08	-0.6
16	6.40	6.46	-0.06	-0.9

*Calculated from Equation 9.

that for $X/R=41$, as much as 50W is available, which equates to an output current of 10A.

Capacitive division improves regulation

If you disconnect the dc load of the basic rectifier in Figure 1, the circuit's output voltage rises to the peak value of the input voltage. C_o , the rectifier diodes, and, momentarily, a reconnected load must accommodate this output voltage unless you use one of several methods to provide better load regulation.

For example, a capacitive voltage divider comprising C_1 and C_2 substantially reduces the large value of the no-load output voltage (Figure 5a). Because both arms of the divider are reactive, efficiency remains 100% with ideal components. A simple way to analyze this circuit is to represent V_i , C_1 , and C_2 by a Thevenin-equivalent network, comprising a voltage source V'_1 in series with an effective capacitance, C , where $C=C_1+C_2$ and

You can use this new V'_1 and C in the earlier design pro-

$$V'_1 = V_i \frac{C_1}{C} \quad (18)$$

cedure. Say, for example, that you want to reduce the previous design example's maximum output voltage, which occurs at no load, to 24V. Now you can use Equation 4 to perform step 4 of the design procedure. Note that in place of the peak ac input voltage of $\sqrt{2} \times V_r$, you substitute 24V. Then, using $V_o=12.26V$ and $R=12.26\Omega$, Thus, $C=1/2 \pi 50 \times 6.93=459 \mu F$. From Equation 18,

$$X = \frac{2 \cdot 12.26}{\pi} \cdot \frac{24 - 12.26 - 0.85}{12.26} = 6.93\Omega \quad (19)$$

$C_1=CV'_1/V_i=34 \mu F$, where $V'_1=\sqrt{2} \times 230V$. Hence, $C_2=C-C_1=425 \mu F$. At step 5, you can calculate the output capacitance, C_o , as follows:

The modified Thevenin equivalent of the rectifier's out-

SIMPLE STEP-DOWN, NONISOLATED RECTIFIER

$$C_o = \frac{0.24 - 0.10 \log_{10}(6.93/12.26)}{50 \cdot 12.26 \cdot 0.042} = 10.3 \text{ mF.} \quad (20)$$

put comprises a 23.15V-dc source in series with a resistance of $1/4fC=10.9\Omega$, giving much better voltage regulation than the original design. For example, at the half-load current of 0.5A, the calculated voltage rises to $23.15-0.5 \times 10.9=17.7V$, which is 1.48 times the full-load voltage of 12V, instead of 168V, which is 14 times the full-load voltage. A graph of dc output voltage vs load current for the first example and for the modified version using the C_1/C_2 voltage divider clearly shows much-reduced load regulation of the second circuit (Figure 5b).

The short-circuit output current is now $23.15V/10.9\Omega=2.12A$, which is double that of the original circuit. Because the diode bridge effectively short-circuits C_2 , the input current under these conditions is which evaluates in this case to 2.46A.

$$I_{I(\text{SHORT})} = 2\pi f C_1 V_1, \quad (21)$$

PSpice simulation confirms the validity of this design. The main drawback is the increased number and size of the capacitors, although this aspect may be unimportant at low power levels.

Another method to improve regulation, in lieu of using C_2 , is to connect a zener diode or metal-oxide varistor across the dc output to provide voltage limiting. The breakdown voltage should be somewhat larger than the normal maximum voltage.

Yet another trick is to use a shunt regulator, such as R_3 and D_5 (Figure 6), to stabilize the output voltage. In this case, the breakdown voltage should equal the desired output voltage, and X should be low enough to maintain current through the zener diode under all conditions.

Carefully choose C

Film or ceramic capacitors are convenient for values of series capacitance, C, as high as several microfarads. For higher values, electrolytic capacitors are usually smaller and less costly. When you use polarized types, you need to connect the two capacitors back to back and shunt them with antiparallel diodes to prevent reverse voltage (Figure 7). The capacitors' ripple-current rating should be at least equal to the largest ac-line current, such as the current with the load short-circuited.

However, for safety and reliability, C should be a Class X capacitor—rated for continuous ac-line operation—because it is effectively connected across the line if the output is a low voltage or a short circuit. Suitable dielectrics include polypropylene film and paper, such as those used in motor-run and lighting-ballast capacitors. Fast voltage transients cause high currents to flow through C, so it is beneficial to place a small resistance in series as a current-spike limiter, such as R_1 in Figure 6. A value of X/10 usually suffices for this resistor. The cost is lower efficiency because R_1 dissipates power equal to $I_1^2 R_1$. Recall that I_1 is the rms value of the input current, which is higher than the dc output current because of the input current's waveform.

TABLE 2—EXPERIMENTAL, ANALYTICAL, AND SIMULATION RESULTS

	Experiment	Analysis	Simulation
R=0.11Ω (short circuit):			
$V_{O(\text{CORRECTED})}$ (V)	0.11	0.00	0.11
I_o (A)	1.01	1.02	1.03
ΔV_o (Vp-p)	—	—	0.15
R=6.06Ω:			
$V_{O(\text{CORRECTED})}$ (V)	6.00	5.93	6.08
I_o (A)	0.99	1.00	1.00
ΔV_o (Vp-p)	0.44	0.29	0.39
R=12.37Ω (design point):			
$V_{O(\text{CORRECTED})}$ (V)	12.00	11.97	12.16
I_o (A)	0.97	0.98	0.98
ΔV_o (Vp-p)	0.44	0.39	0.41
R=18.75Ω:			
$V_{O(\text{CORRECTED})}$ (V)	18.00	17.87	18.11
I_o (A)	0.96	0.96	0.97
ΔV_o (Vp-p)	0.44	0.45	0.43
R=25.53Ω:			
$V_{O(\text{CORRECTED})}$ (V)	24.00	23.90	24.14
I_o (A)	0.94	0.95	0.95
ΔV_o (Vp-p)	0.50	0.48	0.45
R=32.26Ω:			
$V_{O(\text{CORRECTED})}$ (V)	30.00	29.67	29.94
I_o (A)	0.93	0.93	0.93
ΔV_o (Vp-p)	0.50	0.51	0.47
Notes: I_o =output current, $V_{O(\text{CORRECTED})}$ =desired dc output voltage, ΔV_o =output voltage ripple, and R is calculated from V_o/I_o using experimental values.			

If you pull the power plug from the ac wall outlet while the rectifier is operating, C can retain energy that depends on the line-voltage phase at the moment of disconnection. Subsequently, if you touch the power plug, you might receive an electric shock. To prevent this possibility, you can connect a high-value bleed resistor across the rectifier's ac input, such as R_2 in Figure 6. The time constant, $C \times R_2$, should be less than 1 sec. Again, the resistor reduces efficiency, dissipating the power of V_1^2/R_2 . Alternatively, if you don't use the C_1-C_2 divider, placing R_2 in parallel with C somewhat reduces the power in R_2 . Finally, the rectifier is frequency-sensitive, so take care when designing equipment to be used at both 50 and 60 Hz. EDN

References

1. *Nickel-Cadmium Battery Application Handbook, Third Edition, No. 211B5000AC, Gainesville, FL, General Electric Co, Battery Business Department, 1986, pg 3-23 to 3-24.*
2. "117V ac/220V ac—5V/20A switching-mode power supply according to the single-phase feed-forward converter principle, TDA 4718 and SIPMOS FET," Application note,

SIMPLE STEP-DOWN, NONISOLATED RECTIFIER

Siemens AG.

3. Nührmann, D, *Das große Werkbuch Elektronik, Teil B*, Franzis-Verlag, Munich, 1989, pg 2583.

4. Scoles, GJ, *Handbook of Rectifier Circuits*, Ellis Horwood, Chichester, UK, 1980, pg 110.

5. "Limits for harmonic current emissions (equipment input current 16A per phase)," IEC standard 1000, Part 3, Section 2, 1995.

6. Sokal, Nathan O, K Kit Sum, and David C Hamill, "A capacitor-fed, voltage-step-down, single-phase, non-isolated rectifier," Conference Proceedings, IEEE 12th Annual Applied Power Electronics Conference, February 1998, IEEE Catalog No. 98CH36154, Paper No. 5.2, Volume 1, pg 208.

Acknowledgment

The authors thank YH Lim for his assistance in making the experimental measurements and R Redl, AS Kislovski, TA Lipo, and RP Severns for helpful suggestions.

Authors' biographies

Nathan O Sokal is president and founder of Design Automation Inc (Lexington, MA), where he has worked for 33 years. The company provides electronics-design review, product design, and consulting for equipment-manufacturing clients. Sokal holds eight patents in power electronics and has published one book and more than 100 technical papers. He holds BSEE and MSEE degrees from the Massachusetts Institute of Technology

(Cambridge, MA). You can reach him at 73507.247@compuserve.com. If you supply your e-mail address, he will send you a MIME-encoded zipped MS Word 7.0 file of the conference paper in Reference 6. Or, send a self-addressed #10 envelope for a paper copy.

*K Kit Sum is an independent consultant (Milpitas, CA) in power-electronics design. He has a BSEE from Northern Polytechnic (London) and is the author of *Switch Mode Power Conversion*, which is published by Marcel Dekker Inc (New York). Sum also holds a PhD in oriental medicine from Samra University of Oriental Medicine (Los Angeles).*

David C Hamill is a senior lecturer at the Surrey Space Centre, University of Surrey, Guildford, UK. He teaches and researches power electronics for space applications and has developed dc/dc converters for small satellites. He has a PhD from the University of Surrey and is a member of IEE and IEEE. In his spare time, he participates as a member of the Donkey Breed Society, the British Mule Society, and the American Donkey and Mule Society.

VOTE

Please use the Information Retrieval Service card to rate this article (circle one):

High Interest	Medium Interest	Low Interest
582	583	584