



```

REM Follow line - program demonstrates line tracker
REM print sensor number that line is currently under
REM ss 2/9/98

CONST CRLF AS STRING = "\013\010"
DECLARE baseline AS LONG ARRAY
DECLARE sensor_output AS LONG ARRAY
DECLARE deviation AS LONG ARRAY
GLOBAL index AS INTEGER, channel AS INTEGER, n AS INTEGER, lost AS
INTEGER

REM sensor array calibration must be done while not over a line
SUBROUTINE calibrate_sensor_array()
    n = 100
    FOR channel = 0 TO 7
        baseline[channel] = 0
        FOR index=1 TO n
            baseline[channel]=baseline[channel]+AIN(channel)
        NEXT
        baseline[channel] = baseline[channel] / n
    NEXT
END

REM read all input channels into array, calc deviation of each channel
from baseline
SUBROUTINE read_sensor_array()
    n = 10
    FOR channel = 0 TO 7
        sensor_output[channel] = 0
        FOR index = 1 TO n
            sensor_output[channel] =
            sensor_output[channel] + AIN(channel)
        NEXT
        sensor_output[channel] = sensor_output[channel]/n -
        baseline[channel]
        REM deviation will be expressed as percent
        deviation[channel] = ABS((sensor_output[channel] *
        100) / baseline[channel])
    NEXT
END

REM find the channel with maximum deviation from baseline
FUNCTION find_line() AS INTEGER
    LOCAL max_deviation AS LONG, best_guess AS INTEGER
    find_line = -1
    FOR channel = 0 TO 7
        IF deviation[channel] > max_deviation
            max_deviation = deviation[channel]
            best_guess = channel
        ENDIF
    END

```

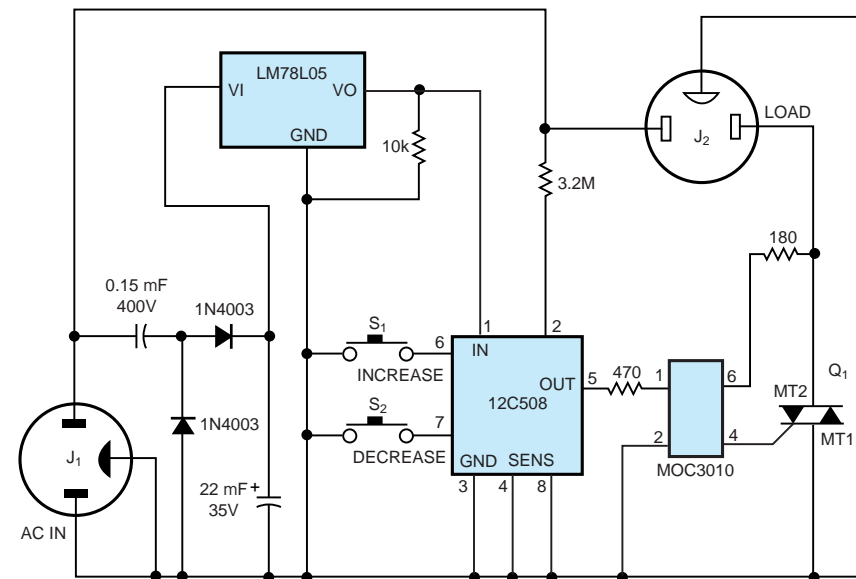

11D22121 DIANE

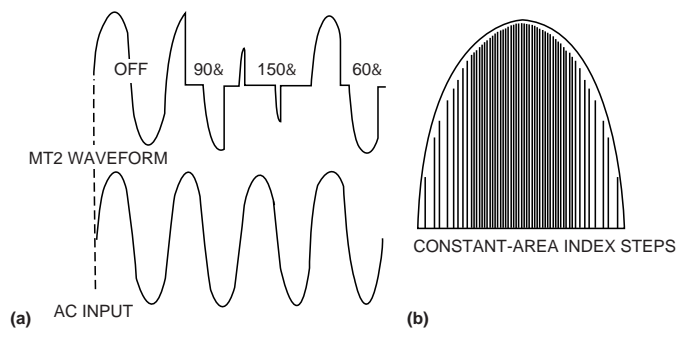

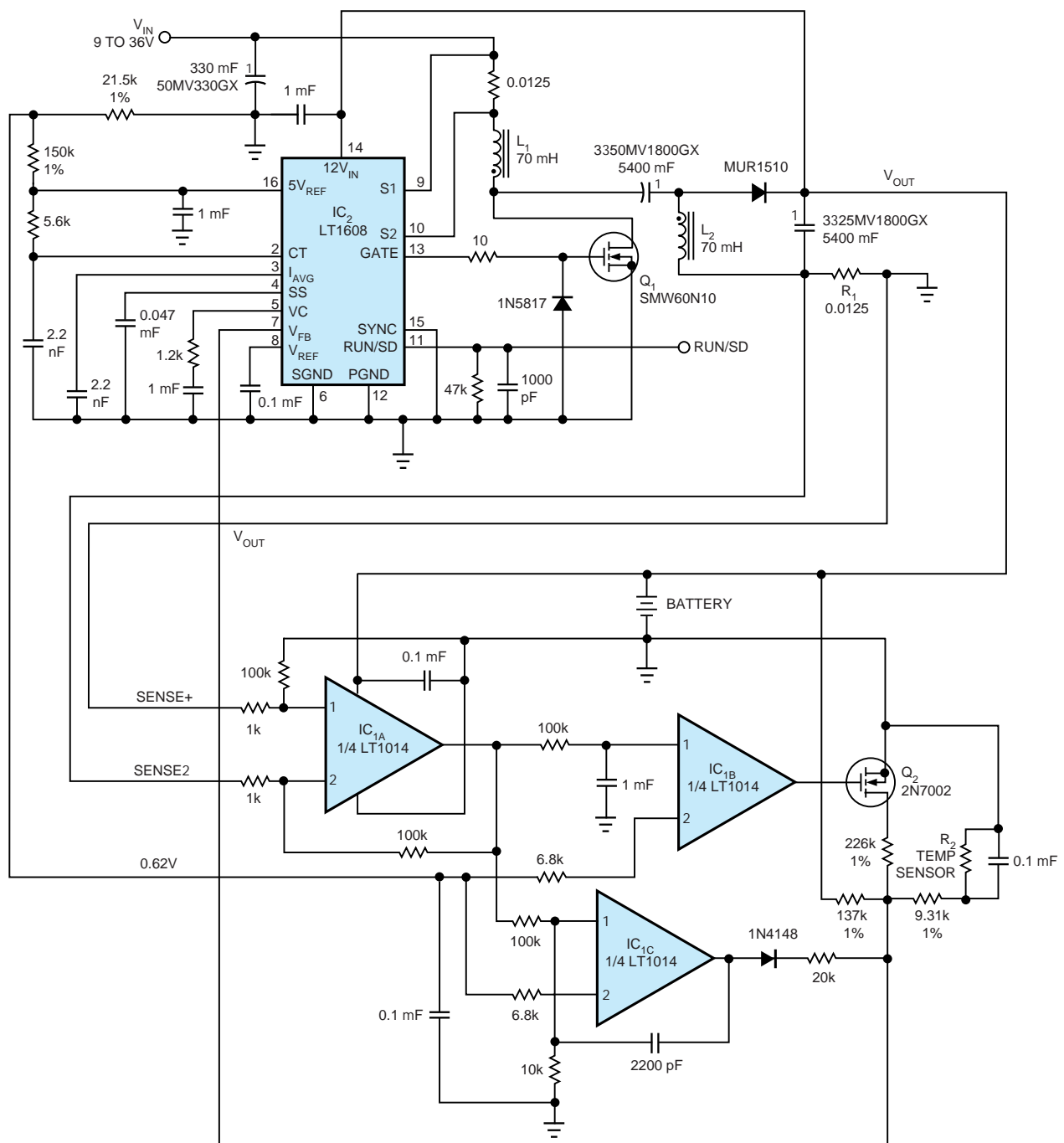

**NOTES:**  
 Q<sub>1</sub> AND D<sub>1</sub> NEED HEAT SINKS.  
 L<sub>1</sub> AND L<sub>2</sub> = COILTRONICS CTX01-14002.

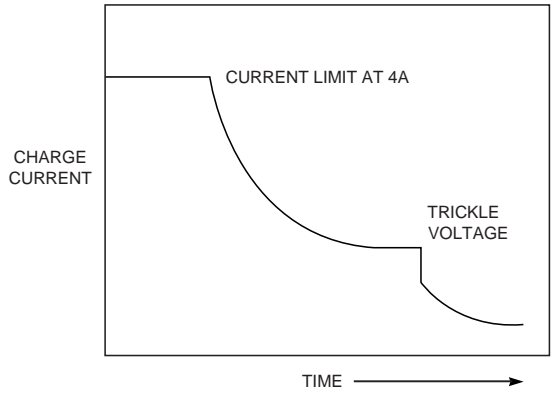



```

'72 is Up Scan Code
KEY 20, CHR$(0) + CHR$(72)
'73 is UpPg Scan Code
KEY 15, CHR$(0) + CHR$(73)
'80 is Down Scan Code
KEY 21, CHR$(0) + CHR$(80)
'81 is DnPg Scan Code
KEY 16, CHR$(0) + CHR$(81)
'75 is Left Scan Code
KEY 22, CHR$(0) + CHR$(75)
'77 is Right Scan Code
KEY 23, CHR$(0) + CHR$(77)
'1 is ESC Scan Code
KEY 17, CHR$(0) + CHR$(1)

ON KEY(15) GOSUB UpPage
ON KEY(16) GOSUB DownPage
ON KEY(20) GOSUB UpLine
ON KEY(21) GOSUB DownLine
ON KEY(22) GOSUB Left
ON KEY(23) GOSUB Right
ON KEY(17) GOSUB Finish

SCREEN 12
DEF SEG = &H40
DEF SEG = PEEK(&HFE) + 256 * PEEK(&HFF)
LINE (0, 4)-(639, 4)
FOR i% = 0 TO 32
  j% = i% * 19.5
  LINE (j%, 4)-(j%, 0)
NEXT i%

h% = 20
addr0% = &H180
fl% = 0
KEY(17) ON
WHILE fl% = 0

KEY(15) ON
KEY(16) ON
KEY(20) ON
KEY(21) ON
KEY(22) ON
KEY(23) ON

LOCATE 1, 40
PRINT (addr0% - &H180) / 80;
FOR i% = 0 TO 255
  FOR j% = 0 TO 128
    NEXT j%
  NEXT i%

```

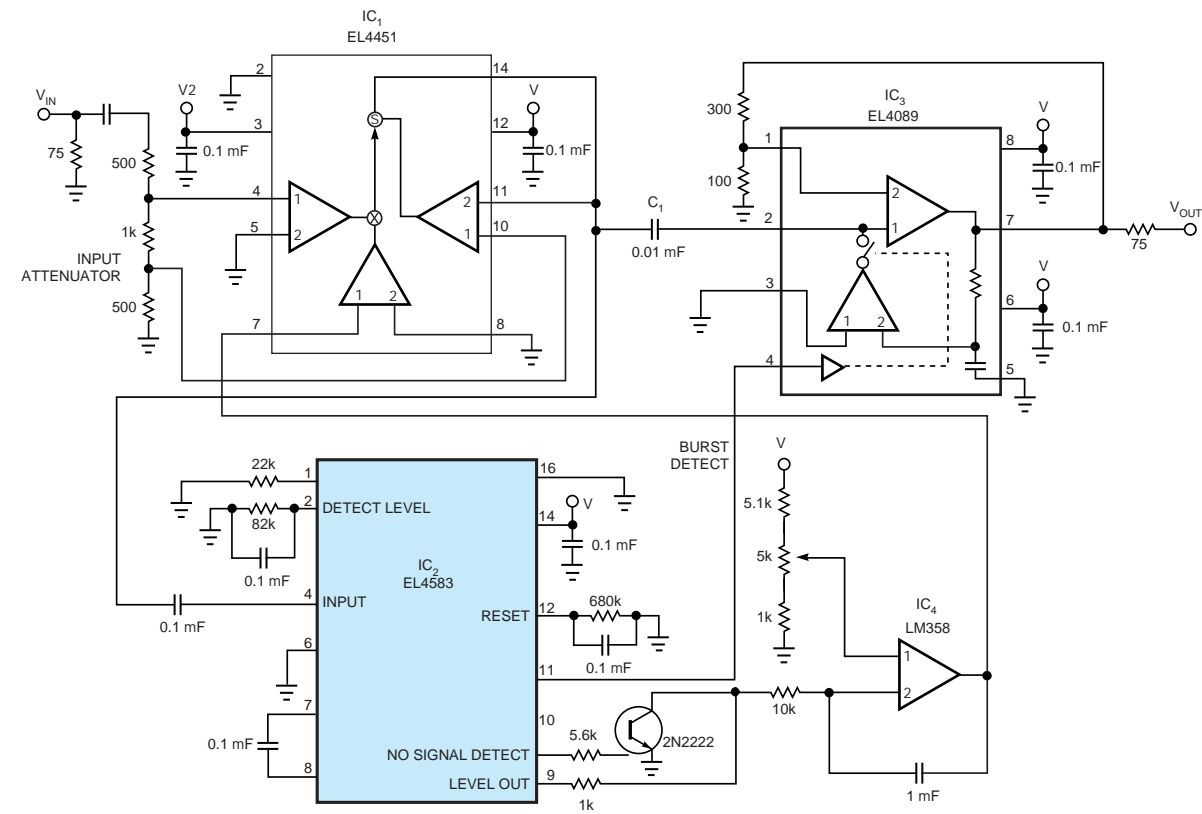

```

CASE &HF8
  LINE (x%, y%)-(x% + 4, y%)
  LINE -(x% + 4, y% + h%)
  LINE -(x% + 7, y% + h%)
CASE &HFC
  LINE (x%, y%)-(x% + 5, y%)
  LINE -(x% + 5, y% + h%)
  LINE -(x% + 7, y% + h%)
CASE &HFE
  LINE (x%, y%)-(x% + 6, y%)
  LINE -(x% + 6, y% + h%)
  LINE -(x% + 7, y% + h%)
CASE ELSE
  LINE (x%, y%)-(x% + 7, y% + h%)
PRINT addr0%
END SELECT
NEXT j%
NEXT i%
WEND

```

```

KEY(15) OFF
KEY(16) OFF
KEY(20) OFF
KEY(21) OFF
KEY(22) OFF
KEY(23) OFF
KEY(17) OFF

```

```

DEF SEG
END

```

```

UpLine:
IF addr0% <= (&H3CE0 * 2) THEN
  CLS 1
  addr0% = addr0% + &H50
END IF
RETURN

```

```

DownLine:
IF addr0% > &H180 THEN
  CLS 1
  addr0% = addr0% - &H50
END IF
RETURN

```

```

UpPage:
IF addr0% <= (&H3CE0 * 2) THEN
  CLS 1
  addr0% = addr0% + &H460
END IF
RETURN

```



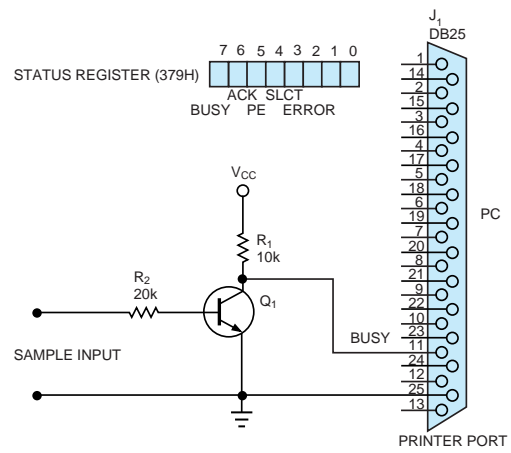

11D2210 PATTY