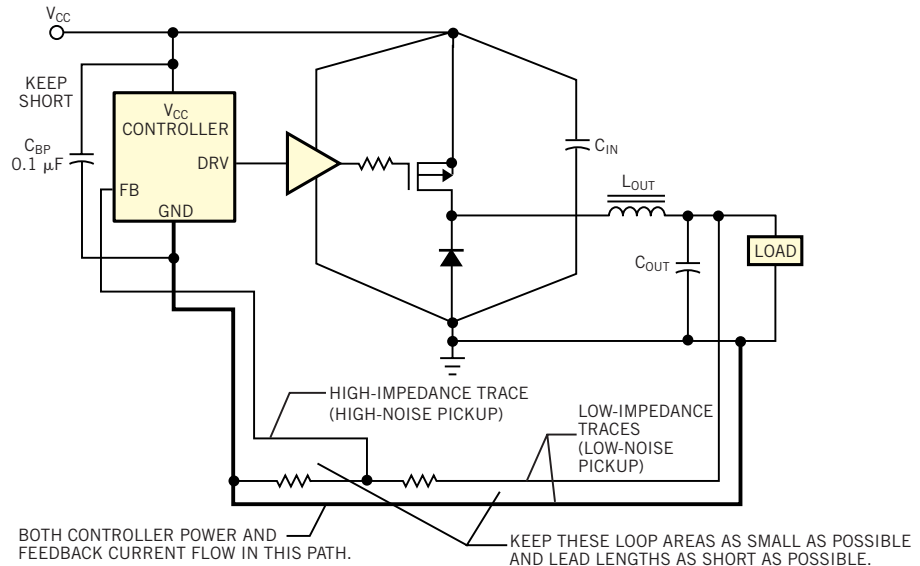

Figure 3



The controller stage is very sensitive to noise pick-up.