

Edited by Bill Travis and Anne Watson Swager

Circuit forms low-frequency circulator

Richard Kurzrok, Queens Village, NY

THE ELECTRONIC circulator made its debut ten years ago (Reference 1). It functioned at VHF as a three-port unit using a Com-linear (now part of National Semiconductor, www.nsc.com) CLC 406 operational amplifier. The circuit in **Figure 1** extends the circulator's performance to four-port operation at low frequencies, using the readily available 941 (equivalent to the ubiquitous 741) and LM318 op amps. **Table 1** shows the measured data for the 741-equivalent op amp. **Table 2** shows the measured data for the LM318 op amp. The four-port circulators in **Figure 1** use 50Ω impedance levels. The circuit can readily accommodate other impedance levels, such as 75 and 600Ω. You can see that for typical circulator operation at frequencies below 50 kHz, you can use the 741-

Figure 1

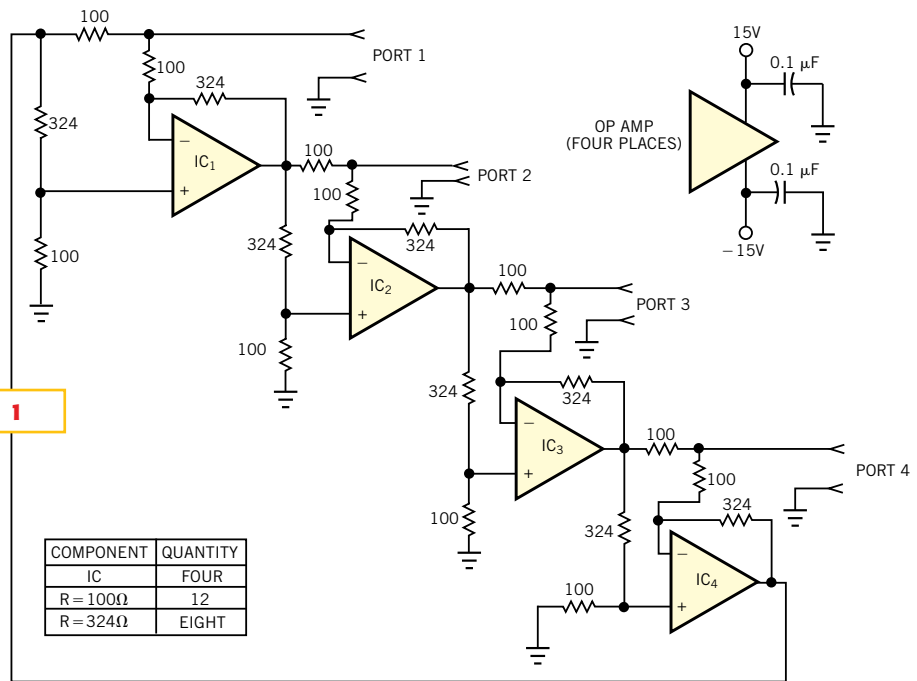

An electronic circulator is useful for isolation and equalization.

TABLE 1—MEASURED DATA FOR 741-EQUIVALENT OP AMP

Frequency (kHz)	Forward loss (dB)	Reverse isolation (dB)
2	0.5	50.2
20	0.5	44.1
50	1	38
100	4.1	33

equivalent op amp. For typical operation at speeds as high as 1 MHz, you would use the LM318 op amp. The resistors in **Figure 1** are metal-film units with ±1% tolerances. The circulator breadboards use open (not shielded) construction,

TABLE 2—MEASURED DATA FOR LM318 OP AMP

Frequency	Forward loss (dB)	Reverse isolation (dB)
10 Hz to 100 kHz	0	Greater than 56
100 kHz	0.1	Greater than 56
500 kHz	0.5	45
1 MHz	0.9	34
1.6 MHz	0	29.5
3.3 MHz	3	25.5

and the components are soldered to the vector board. The ICs use commercially available sockets soldered to the vector board.

- Circuit forms low-frequency circulator 107
- Use printer port as programmable frequency generator 108
- Trace voltage-current curves on your PC 112
- Circuit makes simple FSK modulator 116

You can use the electronic four-port circulators in various applications with the fourth port terminated. You can configure baseband-amplitude and group-delay equalizers using the electronic circulator (references 2 and 3). You can also use the circuit as a low-frequency return-loss bridge or as an electronic isolator. Low-frequency op amps are available as quads with four independent op amps. You can configure a miniaturized, low-

cost version of the circulator using surface-mount pc-board techniques.

REFERENCES

1. Wenzel, C, "Low Frequency Circulator/Isolator Uses No Ferrite or Magnet," *RF DESIGN*, July 1991.
2. Kurzrok, R, "Amplitude Equalizer is Circulator Coupled," *Microwaves*, Volume 10, September 1971, pg 50.
3. Kurzrok, R, "Circulator-Coupled

Equalizers Applicable to High-Speed Data Links," *Applied Microwave & Wireless*, June 2001, pg 86.

Is this the best Design Idea in this issue? Vote at www.ednmag.com.

Use printer port as programmable frequency generator

K Kanniappan, IGCAR, Tamil Nadu, India

A SIMPLE AND INEXPENSIVE circuit (Figure 1) and a simple C program (Listing 1) are all you need to turn your PC's printer port into a programmable frequency generator. Using a few low-cost and readily available components, the circuit occupies little space and is easily attachable to the printer port. The circuit has advantages over a 555-based

stable multivibrator in that it eliminates the tedious task of adjusting a potentiometer while you watch a frequency counter or oscilloscope. With the circuit in Figure 1, you need only enter the desired frequency, and the PC does the rest. The circuit uses a MAX5130 low-power, programmable, 13-bit DAC, IC₁; an OP07 buffer; and an AD537 VFC (voltage-to-

frequency converter). The PC controls the DAC using a three-wire serial interface. It also uses the data lines D0 to D2 of the data port (0×378_h) of the printer interface to send the CS (chip-select), data, and CLK (clock) signals to the DAC. Depending on the data it receives from the PC, the DAC produces a voltage output of 0 to 4.0955V in 8192 steps with a step resolu-

Figure 1

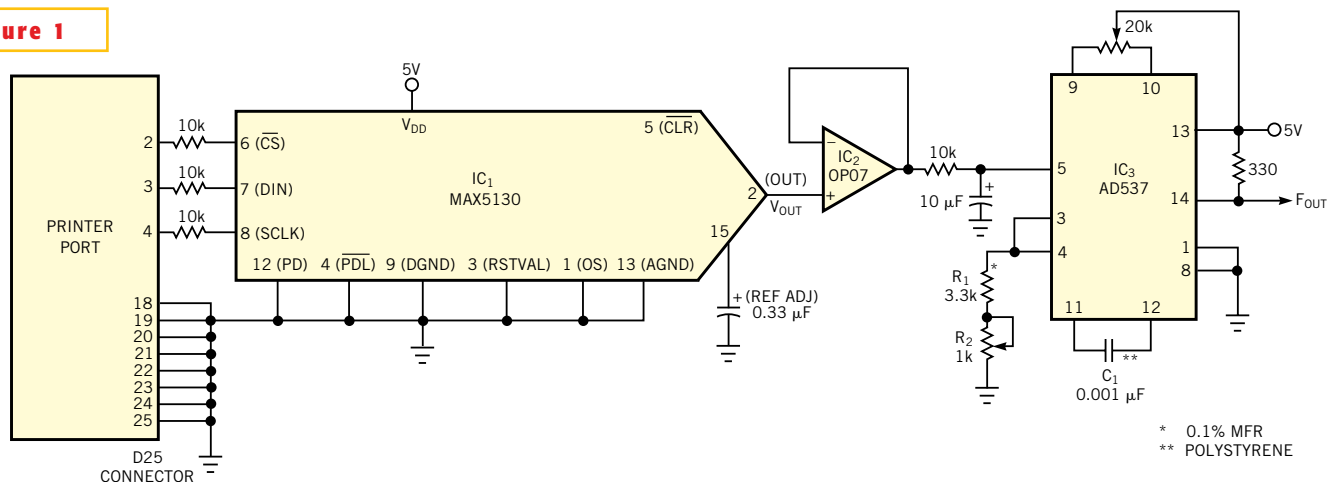

* 0.1% MFR
** POLYSTYRENE

Turn your PC's printer port into a programmable frequency generator with this simple circuit.

tion of 0.5 mV. Thus, a data word of $0 \times 000_h$ produces a DAC output of 0V, and a data word of $0 \times 1fff_h$ produces a DAC output of 4.0955V. Using the 2.5V internal reference, the DAC output and the data input follow the equation $V_{OUT} = 2.5(DATA/8192) \times GAIN$.

After IC₂ buffers it, the DAC output drives the VFC and sets its frequency output according to the following equation: $f_{OUT} = V_{OUT} / (10(R_1 + R_2)C_1)$ Hz. For the values of R₁, R₂, and C in **Figure 1** and the cited DAC-output range, the output of the VFC and hence the frequency of the programmable-frequency generator varies from 0 to 10 kHz in 8192 steps with a frequency resolution of 1.22 Hz. You choose and trim the values of R₁ and R₂ to produce a current range of 0 to 1 mA for a DAC output of 0 to 4.0955V.

These values ensure good linearity (typically 0.01%) between V_{OUT} and f_{OUT}. Potentiometers P₁ and P₂ adjust f_{OUT} at the lower and higher ends of the frequency range, respectively. The C program in **Listing 1** obtains the desired frequency from the user and calculates the required output from the DAC to apply to the VFC. It then works out the ACTUALDATA to send to the DAC for mode control. The d2b routine converts the ACTUALDATA into 16-bit binary data. The program enables the DAC (\overline{CS}) low and then serially clocks the binary equivalent of ACTUALDATA, starting one bit at a time from the MSB to the LSB, to the data pin of the DAC. With the LSB set at the data pin, the low-to-high transition of the clock latches the ACTUALDATA completely into the DAC and sets f_{OUT} to the

desired value. You can download **Listing 1** from the Web version of this article at EDN's Web site, www.ednmag.com. You can easily change the frequency range by changing the value of C. For example, with R₁ and R₂ unchanged, you can extend the frequency to 100 kHz by changing C to 0.001 μF instead of 0.01 μF. You can also increase the frequency range by using a VFC with a higher frequency capability.

Is this the best Design Idea in this issue? Vote at www.ednmag.com.

LISTING 1—PROGRAMMABLE FREQUENCY GENERATOR

```
#include<stdio.h>
#include<conio.h>
#include<math.h>
#include<bios.h>
#include<dos.h>

#define CLK1 0x04 /* Clock Pulse High*/
#define CLK0 0xfb /* Clock Pulse Low*/
#define CS1 0x01 /* Chip Select high to deactivate DAC*/
#define CS0 0xfe /* Chip Select low to activate DAC*/
#define DATA1 0x02 /* Data Pulse High*/
#define DATA0 0xfd /* Data Pulse low*/

int c[16],dport,ACTUALDATA,out,k; /*Global Declarations*/
float VOUT; /*DAC OUTPUT*/

void d2b(unsigned int x, int*c)/*Routine for Decimal to Binary Conversion*/
{
    int i;
    for(i=0;i<=15;i++)
        *(c++)=(x>>i) & 0x1;
}

float ftov() /*Hertz to DAC output Conversion Routine*/
{
    int HERTZ;
    printf("\n\nEnter the frequency within 0 to 10000Hz:");
    scanf("%d",&HERTZ);
    VOUT=0.00040955*HERTZ;
    printf("\n VOUT=%f\n",VOUT);
    return VOUT;
}

void CLOCK_DAC(void)/*Routine for clocking the DAC*/
{
    out|=CLK1;
    outportb(dport,out);/*Setting the clock high*/
    delay(1);
    out&=CLK0;
    outportb(dport,out);/*Setting the clock low*/
    delay(1);
}

void LOAD_DACDATA(int*c)/*Routine for loading actual data into the DAC*/
{
    out|=CS1;
    outportb(dport,out);/*Chip Select high to disable DAC*/

    delay(1);
    out&=CS0;
    outportb(dport,out);/*Chip Select low to enable DAC*/
    delay(1);
    printf("\nDATA loaded into the DAC=");
    for(k=15;k>=0;k--)
    {
        out|=c[k];
        outportb(dport,out);
        printf("%d",c[k]);
        delay(1);
        CLOCK_DAC();
    }
    out|=CS1;
    outportb(dport,out);
    delay(1);
}

main()
{
    int v,inc;
    float y;
    unsigned int x;
    double fraction, integer, number;
    clrscr();
    printf("\tUse Your Printer Port as a Programmable Frequency Generator");
    printf("\n\t\t\t\t\tby\n");
    printf("\tK.Suresh,MSD,IGCAR,Kalpakkam,TamilNadu-603102,India");
    dport= peek(0x40,8);/*Check up for availability of Printer Port*/
    if (dport==0)
    {
        printf("\n\n LPT NOT AVAILABLE! EXITING.....");
        exit(1);
    }
    printf("\n\nAddress of the printer port found =0x%X",dport);
    ftov();
    y=(VOUT*8192)/(2.5*1.6384);
    v=y/1;
    number=y;
    fraction = modf(number, &integer);
    if (fraction<0.44)
        inc=0;
    else inc=1;
    ACTUALDATA=16384+v+inc; /*Actual data including the Control Word for DAC*/
    d2b(ACTUALDATA,c);
    LOAD_DACDATA(c);
    return 0;
}
```

Trace voltage-current curves on your PC

Clayton Grantham, National Semiconductor, Tucson, AZ

SOME YEARS AGO, one of the fundamental electronic instruments was the laboratory curve tracer. A CRT display would sweep out terminal behavior (current versus voltage) from which you could derive mathematical models. Classic presentations of diodes, transistors, and other devices enlightened designers about linear and nonlinear operation. From the displays, you could determine the bias points for optimum design performance. Today, however, you rarely find the classic curve tracers in the lab. Instead, you find design-simulation

software, such as Spice, that's removed from hands-on, empirical analysis. Spice models now exist for almost all electronic components. Characterization analyzers still make the voltage-current measurements but not at the design-engineer level. Rather, departments are dedicated to characterizing processes and components and incorporating these characteristics into the simulated models. The low-cost circuit in **Figure 1** allows you to return to the hands-on approach by using your PC as a limited curve tracer.

The curve tracer sweeps out seven log-

arithmic-scaled currents from 1 μA to 1 mA while measuring the voltage, 0 to 5V (3.3V on some PCs), at each step. The circuit uses a programmable current source to force increasing discrete current values and samples the voltage at the I_{OUT} terminal at each step. A classic curve tracer continuously sweeps a voltage while measuring the sourced current. The program control resides in Excel (running in Office 2000) macros that perform I/O operations through the LPT₁ port of the PC. You can download the Excel program from EDN's Web site, www.ednmag.com.

Figure 1

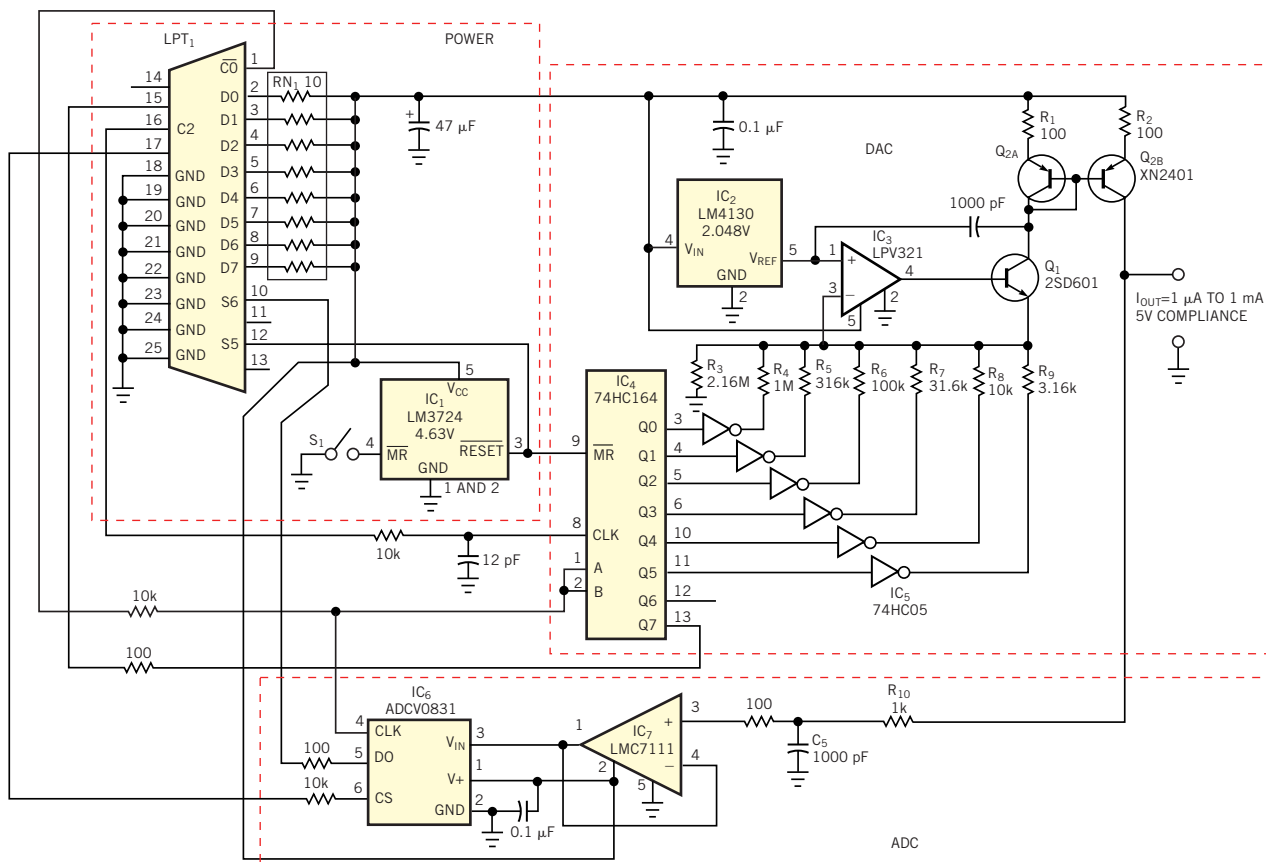

Remember the classic Tek curve tracers? You can easily configure something similar on your PC.

The program uses the free file “Input32.dll” to bit-wise control the parallel port’s digital I/O. The author of the .dll file is Jonathan Titus, editorial director of *Test and Measurement World*. You load CurveTracer.xls with its macros, connect the circuit of **Figure 1** to the parallel port, and then run a macro called ControlPanel.

A user form pops up in the spreadsheet and connects the curve-tracer force and measurement actions with the electronics (**Figure 2**). The possible operations are a single voltage measurement, a single forced-current output, or a sweep of current steps lasting 2.8 msec each and a voltage measurement at each step. The voltage measurements go into cells B4 to B10 in the spreadsheet. The resulting graph shows an x-y scatter plot of the data in cells A4 to B10. With this use of macros within Excel, all the graphing, analysis, and data storage common to Excel are still available to use. You can test the terminal behavior of many electronic components with this simple curve tracer. Resistors yield a linear plot whose slope is the resistor value ($R=V/I$). Diodes exhibit a nonlinear plot ($I_D = I_S e^{qV_D/kT}$). You can also plot a diode’s terminal behavior on a logarithmic current scale with a simple click within Excel’s charting capabilities. Some other application examples are forward-biased transistor junctions, LEDs, and relay coils.

The components in **Figure 1** provide operation as low as 3V and low power consumption (low quiescent current). In the PWR block, resistor network RN₁ isolates and combines eight LPT₁ outputs at D0 to D7 to power the circuit. The supervisory circuit, IC₁, monitors the voltage from the LPT1 port. Use the LM3724 4.63V option for 5V PCs and the 3.08V option for 3.3V PCs. The reset output of IC₁ goes back to the parallel port at terminal S5 for software-error checking and clears IC₄ at start-up. IC₁ also has a manual reset that provides direct user control. If you press momentary switch SW₁, the output current resets to 1 μA. IC₂ through IC₅, Q₁, Q₂, and associated resistors R₁ through R₉ form a current-output D/A converter. Servoamplifier IC₃ sets Q₁’s collector current. This current is a function of IC₂’s reference voltage divid-

Figure 2

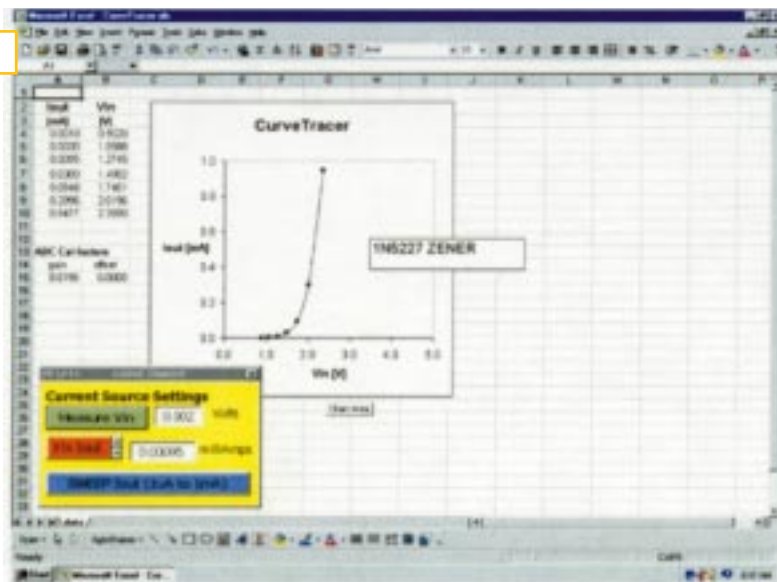

This curve-tracer user form, which floats in front of an Excel spreadsheet, controls the curve tracer’s electronics.

ed by the parallel combination of R₃ to R₉. For the lowest current, 1 μA, only R₃ connects (2.048V/2.16 MΩ). For the highest current (1 mA), all the resistors connect in parallel (2.048V/2.16 kΩ).

You select resistor values for a cumulative half-decade change in I_{OUT}. I_{OUT} steps by the square root of 10 in value. With only these seven resistors, the circuit covers three decades of current range. The pnp pair, Q_{2A} and Q_{2B}, mirrors Q₁’s collector current to the terminal I_{OUT}. Emitter-degeneration resistors R₁ and R₂ improve the mirror’s output resistance. Shift register IC₄ and open-drain inverter IC₅ select which of the resistors to connect via program control. IC₄’s input and clock connect the parallel port at C0 and C2 for serial shift-in operation. IC₅’s on-resistance is lower than 40Ω. IC₆ and IC₇ perform voltage measurements (the ADC block). IC₇, a rail-to-rail op amp buffers the lowpass filter comprising R₁₀ and C₅. The serial output of IC₆, D0, connects to the parallel port at S6. IC₆’s clock input provides timing control. When IC₆’s chip-select input goes low, a conversion starts. Pulling I_{OUT} above the PC’s 5V level or below ground could result in circuit and PC damage. To be safe, operate this curve tracer with unpowered components.

The macros in the downloadable list-

ing contain the basic interface features for changing the current-output values and measuring the voltage input. Within module 1, the declaration of Input32.dll must include its directory path. To minimize the effects of differing PC-clock and LPT₁-bus speeds in different PCs, the user form performs a 10-sec timing calibration at initialization. This calibration attempts to set the I_{OUT} steps during a sweep to 2.8 msec. The software uses this time-delay coefficient throughout the program. Also, software-calibration coefficients within the code minimize voltage-measurement gain and offset errors. The spreadsheet maintains these coefficients for ease of changing. Use a voltmeter and a resistor of known value to calibrate. The initial gain coefficient in the spreadsheet for a 5V PC is 5V divided by 2⁸ - 1 (5/255 = 0.0196). The initial offset coefficient is zero. You can also calibrate the I_{OUT} current values in the spreadsheet. The user-form references these spreadsheet values. With external calibration, you can attain better than 1% error.

Is this the best Design Idea in this issue? Vote at www.ednmag.com.

Circuit makes simple FSK modulator

Shyam Tiwari, Sensors Technology Ltd, Gwalior, India

THE NEED FOR a compact telemetry system poses a challenge

Figure 1

for designing a small, light, low-component-count system. Interfacing serial data from the microprocessor is also difficult because most low-cost RF transmitters do not accept dc levels at the input. Commercial FSK (frequency-shift-keying) modulators are bulky and need many passive components. The circuit in **Figure 1** uses a single NOT gate (inverter), an On Semiconductor NL27WZ14 in a surface-mount package, to generate continuous FSK data from TTL-level signals. The outputs from this circuit are compatible

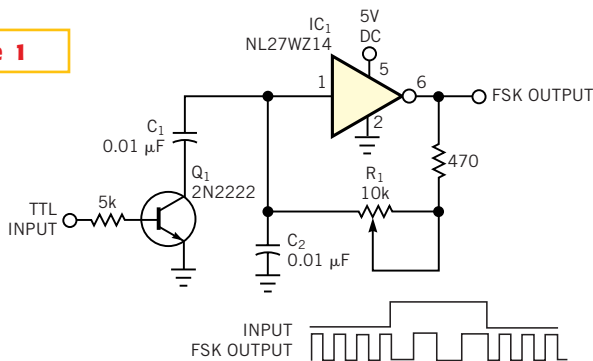

An FSK modulator uses a single inverter with minimal added components.

with available transmitters. When the TTL input has a low level, the circuit is a continuously running oscillator, producing approximately 2400 Hz (adjustable

with R_1). When the input assumes a high level, the oscillator's frequency reduces by one-half with the introduction of a capacitor in the timing circuit via Q_1 . The inverter IC can accommodate an operating frequency of approximately 80 kHz. You can easily operate the FSK modulator at higher frequencies, such as 4800 and 9600 Hz, by reducing the values of the timing capacitors C_1 and C_2 .

Is this the best Design Idea in this issue? Vote at www.ednmag.com.