

Edited by Bill Travis and Anne Watson Swager

## Transistor latch improves on/off circuitry

Eugene Palatnik, SIMS-BCI, Waukesha, WI

**F**IGURE 1 SHOWS AN example of on/off circuitry commonly used in battery-operated devices.

The p-channel MOSFET,  $Q_1$ , serves as a power switch. When you push the On button,  $S_1$ ,  $Q_1$ 's gate goes low.  $Q_1$  turns on and supplies battery voltage to the dc/dc converter. Depending on the battery voltage in the device, the dc/dc converter might convert the voltage either up or down. In either case, it supplies  $V_{CC}$  to the  $\mu C$ . The  $\mu C$  goes through its power-up software sequence and programs one of its general-purpose I/O pins, setting it to logic one. This operation, in turn, causes saturation of the npn transistor,  $Q_2$ , which "confirms" the power-up state. Later, when the  $\mu C$  decides to power itself off, the  $\mu C$  simply sets its I/O output to logic zero, and  $Q_1$  returns to its off state. The circuit is simple and reliable but has a significant disadvantage. It usually takes a fraction of a second for the dc/dc converter to reach its stable output voltage. Then, the  $\mu C$ 's Reset pulse usually lasts 50 to 200

**Figure 1**

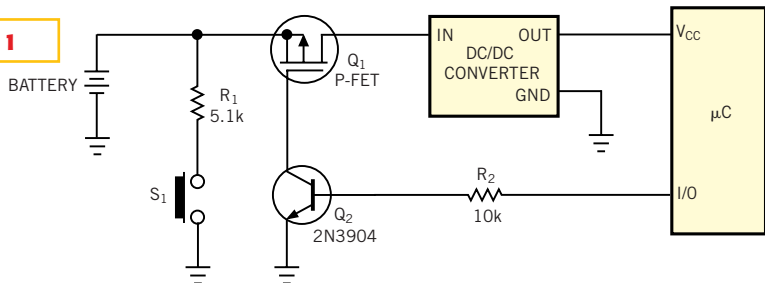

This on/off circuitry is effective but can suffer from turn-on ambiguity.

msec. After the release of Reset, the  $\mu C$  must go through its "housekeeping" start-up code before it has a chance to set its I/O pin to logic one. This delay in some portable systems may be user-unfriendly, because if you don't depress the On button long enough, the system will not power up. The circuit in **Figure 2** eliminates this uncertainty.

The circuit includes a simple two-transistor latch, which the On button switches to the on state. As in **Figure 1**, the p-channel MOSFET,  $Q_1$ , serves as a power switch. When you push the On button,  $S_1$ , it causes saturation of the npn transistor,  $Q_4$ , via the base-current-limiting resistor,  $R_5$ . The collector current of  $Q_4$  flows through  $R_1$  and the base-emitter junction of npn transistor  $Q_3$ , thereby saturating  $Q_3$ .  $Q_3$  redirects some current into the

base-emitter junction of npn transistor  $Q_3$ , thereby saturating  $Q_3$ .  $Q_3$  redirects some current into the

**Figure 2**

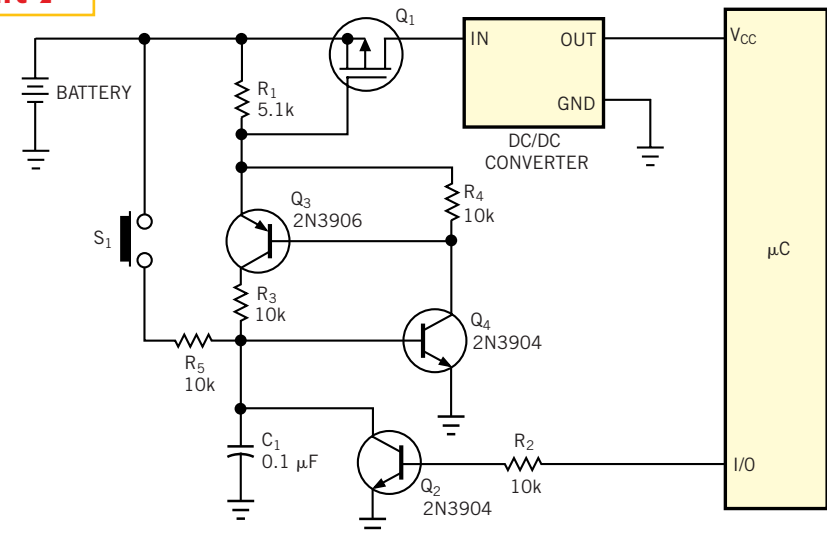

A two-transistor latch provides positive turn-on when you push the button.

Transistor latch improves on/off circuitry .....	157
High-side driver feeds IGBTs and MOSFETs.....	158
Economical circuit drives white LEDs.....	160
Real-time-clock chip makes low-power oscillator.....	162
Everything you wanted to know about wideband, low-frequency transformers.....	162
$\mu C$ makes effective frequency counter....	164
Software provides interrupt system for 8051.....	168
Look-up table facilitates bit flipping.....	168

base-emitter junction of  $Q_4$  and finishes the latching process. At this point, both  $Q_3$  and  $Q_4$  are saturated, and the voltage on the gate of  $Q_1$  is a function of the voltage drop across the base-emitter junction of  $Q_3$  and the saturation voltage of  $Q_4$ . This voltage is approximately 0.9V. The  $\mu\text{C}$  need not confirm the on state of the latch. When the  $\mu\text{C}$  powers up and finishes its housekeeping start-up code, it programs the I/O pin to logic zero.

Later, when the  $\mu\text{C}$  decides to power itself off, it programs the I/O pin to log-

ic one and stops.  $Q_2$  turns off  $Q_4$ , resetting the latch to its initial off state.  $R_4$  lowers the equivalent input impedance of  $Q_3$ . This function improves EMI and ESD noise immunity and prevents the circuit from turning itself on in the presence of strong electromagnetic fields. Capacitor  $C_1$  in combination with  $R_5$  protects  $Q_4$  and  $Q_2$  from direct ESD into the push-button. Some portable devices use undervoltage-lockout circuitry. This circuitry usually uses a voltage comparator with a built-in voltage reference. If the

battery voltage drops below the threshold, the output of the comparator (usually an open-drain type) switches low. If your portable system uses this type of circuitry, you can connect the open-drain output of the comparator in parallel with  $Q_2$ , thus preventing the latch from turning on if the battery voltage is too low.

**Is this the best Design Idea in this issue?** Vote at [www.ednmag.com/ednmag/vote.asp](http://www.ednmag.com/ednmag/vote.asp).

## High-side driver feeds IGBTs and MOSFETs

Carlisle Dolland, Honeywell Engines and Systems, Torrance, CA

**T**HE LOW- TO MODERATE-POWER system in **Figure 1** provides the interface between a pulse-width modulator

and a high-side IGBT (insulated-gate-bipolar-transistor) or MOSFET switch. You can use it to interface TTL or CMOS

circuitry to an H-bridge if you buffer it by a FET driver, such as an ICL7667 or an MIC4423. When OA is positive,  $D_1$  conducts, charging the capacitance of the FET through  $R_1$ . The value of  $R_1$  and the output impedance associated with the drive signal determine the turn-on time of the FET. After the capacitance is charged, the voltage across  $R_1$  is essentially 0V, and  $Q_1$  is off. During the PWM dead time, the gate capacitance discharges through  $Q_1$  and  $R_2$ .  $R_2$  and the  $h_{fe}$  of  $Q_1$  determine the turn-off time of the FET. This circuit achieves turn-on and -off times of less than 150 nsec.

In systems that require higher power, you can use a dual-FET circuit (**Figure 2**).  $R_1$  and  $R_2$  and the output impedance of the PWM or FET driver determine the turn-on time.  $R_1$  and  $R_2$  and the  $h_{fe}$  values for  $Q_1$  and  $Q_2$  determine the turn-off time. The Schottky diodes,  $D_3$  and  $D_4$ , prevent current flow through the collector-base junctions of  $Q_1$  and  $Q_2$  when the drive signal is negative. You can obtain switching speeds higher than 50 nsec at turn-on and 100 nsec at turn-off with this circuit, depending on the output impedance of the transformer drive signal.

**Is this the best Design Idea in this issue?** Vote at [www.ednmag.com/ednmag/vote.asp](http://www.ednmag.com/ednmag/vote.asp).

**Figure 1**

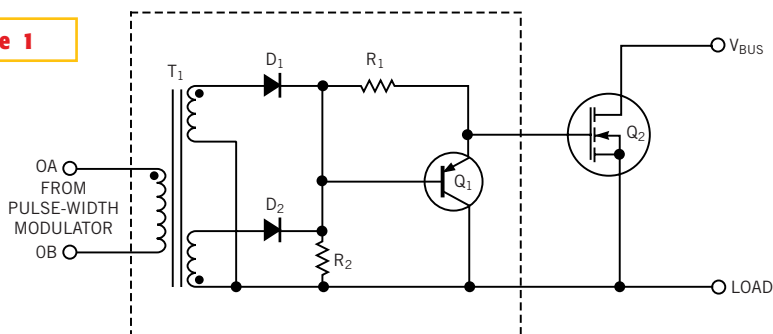

You can use this low-cost circuit to drive high-side FETs or IGBTs.

**Figure 2**

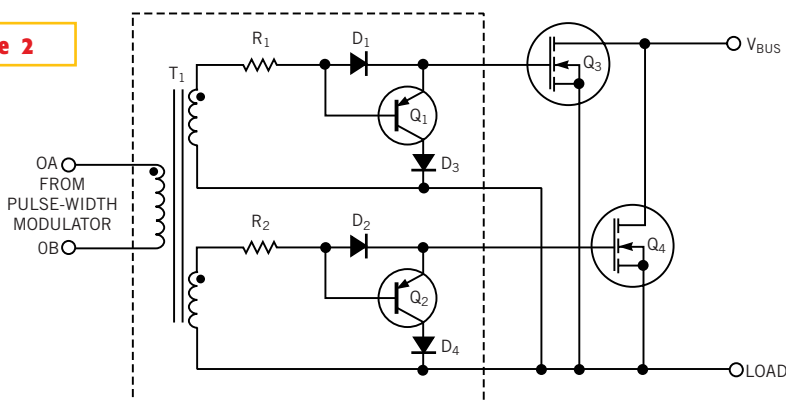

Two FETs in parallel provide more power than the circuit in **Figure 1**.

# Economical circuit drives white LEDs

Eddy Wells, Texas Instruments

**N**EWLY AVAILABLE white LEDs are replacing CCFLs (cold-cathode fluorescent lamps) in handheld applications using a backlit LCD. These applications include PDAs (personal digital assistants), digital cameras, and cellular telephones, to name a few. Advantages of white LEDs over CCFLs include longer life, higher efficiency, and significantly lower operating voltages. Regulating the current in the LED (typically 10 to 30 mA) controls the brightness; the forward voltage in each LED is approximately 3V. The circuit in **Figure 1** provides a means of efficiently controlling LED current in a series-connected string. The TL5001 PWM-controller IC is an older, industry-standard, inexpensive driver. The boost topology of the circuit allows operation from a single or dual lithium-ion cell. The ratings of  $Q_3$ ,  $SD_1$ , and the maximum allowed duty cycle of the IC (programmed with pin DTC) determine the maximum output voltage of the circuit.  $V_{CC}$  comes from a separate 5V supply.

**Figure 1**

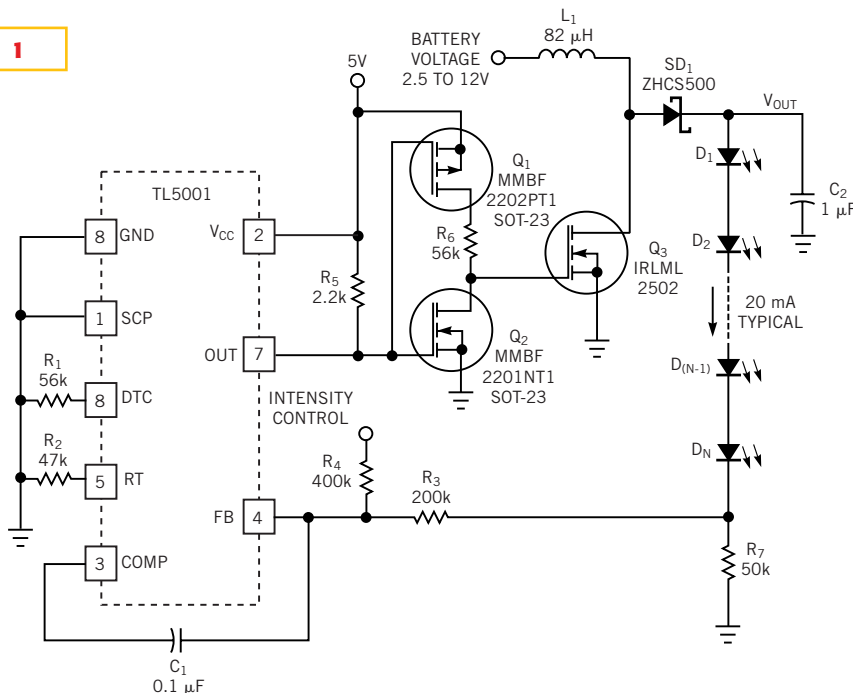

White LEDs provide ideal backlighting for small LCDs.

Trade-offs in the selection of inductor  $L_1$  include size, dc resistance, and inductance value. An 82- $\mu$ H inductor (with 200-m $\Omega$  dc resistance) results in continuous inductor current at higher LED currents, but the current becomes discontinuous at lower levels. The RT pin programs the oscillation frequency at approximately 200 kHz. Because the TL5001 has a relatively weak (20-mA) open-collector output driver and is intended to drive a buck-topology circuit, the circuit uses a low-cost inverter stage comprising  $Q_1$  and  $Q_2$  to efficiently drive  $Q_3$ .  $R_6$  provides controlled turn-on and fast turn-off for  $Q_3$ . The reverse-breakdown voltage of  $SD_1$  must be greater than the  $C_2$ -filtered  $V_{OUT}$ .  $R_7$  senses current in the white-LED string; the error amplifier at the FB pin of

**Figure 2**

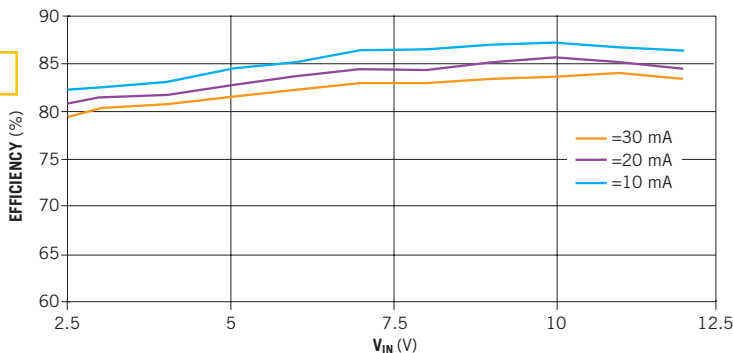

The circuit in Figure 1 provides more than 80% conversion efficiency.

the IC controls the feedback signal at this pin to 1V. You can control the LEDs' intensity by summing in a control voltage via  $R_4$ . **Figure 2** shows the efficiency of a four-LED string. You could obtain approximately 2% higher efficiency by adding a gain-of-5 op-amp stage between  $R_7$  and  $R_3$ , resulting in a lower voltage drop across  $R_7$ . Of course, this slight efficiency improvement adds to the system

cost. For higher power applications, such as notebook computers, you can attach additional LED strings to  $V_{OUT}$ . To maintain uniform intensity in each string, you should add a dummy resistor of the same value as  $R_7$  to each string.

**Is this the best Design Idea in this issue?** Vote at [www.ednmag.com/ednmag/vote.asp](http://www.ednmag.com/ednmag/vote.asp).

# Real-time-clock chip makes low-power oscillator

Yongping Xia, Teldata Inc, Los Angeles, CA

**M**ANY SYSTEMS use watch-crystal-based, 32.768-kHz oscillators. In battery-powered designs, the 32-

kHz oscillator may consume a fairly high percentage of the total power budget. Reduced power consumption equates to

longer battery life, smaller batteries, and smaller products. Ricoh (www.ricoh.com) manufactures more than 10 types of real-time-clock chips, including the RS5C372B (**Figure 1**). This device is an eight-pin IC with a built-in oscillator, programmable periodic interrupts, and an I<sup>2</sup>C interface to a  $\mu$ C. The only function the device in **Figure 1** uses is the 32-kHz oscillator. Using only the IC and the crystal, the circuit consumes low current over its 1.5 to 6V power-supply range, as the table in **Figure 1** shows. The CMOS-based output delivers a waveform with an amplitude of 0V to  $V_{DD}$ .

**Figure 1**

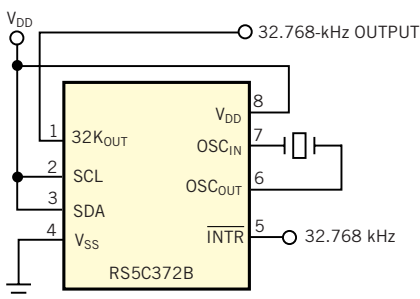

$V_{DD}$ (V)	CURRENT ( $\mu$ A)
1.5	0.9
2	1.1
2.5	1.3
3	1.6
3.5	2.1
4	2.6
4.5	3.2
5	3.9
5.5	4.7
6	5.6

This ultra-low-power oscillator uses only the oscillator portion of a real-time-clock chip.

**Is this the best Design Idea in this issue?** Vote at [www.ednmag.com/ednmag/vote.asp](http://www.ednmag.com/ednmag/vote.asp).

# Everything you wanted to know about wideband, low-frequency transformers

Richard Kurzkrok, Queens Village, NY

**W**IDEBAND, LOW-FREQUENCY transformers are useful components in various passive circuits, such as the return-loss bridge (**Reference 1, Figure 2**). **Figure 1a** shows a conventional transformer. If you connect the transformer windings differently, you can configure a transmission-line transformer (**Reference 2, Figure 1b**). These transformers use a magnetic core of modest size, and unit cost is reasonable. The basic transformer uses a Fair Rite (www.fair-rite.com) toroid (type 597700601), which has a nominal outer diameter of 0.825 in., a nominal inner diameter of 0.525 in., and a nominal thickness of 0.25 in. The toroid uses number 77 material and has an inductance factor (AL) of 1175. To obtain useful performance at audio frequencies, the trans-

**Figure 1**

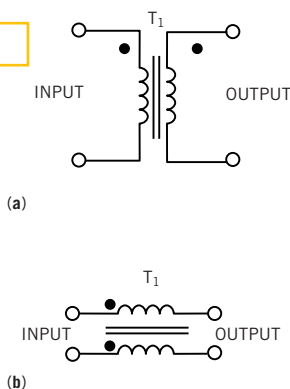

You can use a wideband transformer in conventional mode (a) or in a transmission-line configuration (b).

former uses a 129-turn bifilar winding of number 26 magnet wire. To avoid the use of expensive commercial bifilar wire, you can twist together monofilar red and green windings using a hand drill before winding it on the toroid.

**Table 1** gives the measured performance with 50 $\Omega$  source and load impedances of the conventional transformer in **Figure 1a**. **Figure 1b** shows the schematic diagram of a one-to-one transmission-line transformer. **Table 2** gives the measured performance with 50 $\Omega$  source and load impedances. This transformer provides bandwidth enhancement with useful behavior down to dc. You can use the conventional transformer in **Figure 1a** in a passive return-loss bridge (**Figure 2**) or for stand-alone dc isolation. **Table 3** gives the measured performance of the 50 $\Omega$

return-loss bridge. At 1 MHz, the return-loss bridge exhibits a forward insertion loss of 12 dB and an open-circuit-to-short-circuit ratio of 0.5 dB. You can use the conventional transformer to isolate a grounded signal from a balanced test piece. We built the circuits for the wideband transformers and return-loss bridge using single-clad vector board and enclosed them in die-cast aluminum boxes with BNC connectors.

REFERENCES

1. Wetherhold, E, "Design and Construction of a 9-kHz Highpass Filter and Assembly of a Return Loss Bridge for Filter and PLISN," *Interference Technology Engineers' Manual*, pg 220, 1993.
2. Sevick, J "Transmission Line Transformers," American Radio Relay League, 1990.

Is this the best Design Idea in this issue? Vote at [www.ednmag.com/ednmag/vote.asp](http://www.ednmag.com/ednmag/vote.asp).

**TABLE 1—PERFORMANCE OF A CONVENTIONAL TRANSFORMER**

Frequency (MHz)	Insertion loss (dB)	Frequency (kHz)	Insertion loss (dB)
10	7.2	50	<0.1
8	3.8	20	<0.1
7	2.6	10	<0.1
6	1.9	5	<0.1
4	1	2	<0.1
2	0.5	1	0.15
1	0.3	0.5	0.5
0.5	0.15	0.2	1.7
0.2	<0.1	0.15	2.6
0.1	<0.1	0.1	4.1

**TABLE 2—PERFORMANCE OF A TRANSMISSION-LINE TRANSFORMER**

Frequency (MHz)	Insertion loss (dB)	Frequency (kHz)	Insertion loss (dB)
10	1.7	100	0.15
7	1.2	50	0.15
4	0.9	20	0.1
2	0.6	10	0.1
1.5	0.5	5	0.1
1	0.4	1	0.1
0.5	0.3	0.1	<0.1
0.2	0.2	0.01	<0.1

**TABLE 3—DIRECTIVITY OF THE RETURN-LOSS BRIDGE**

Frequency (kHz)	Directivity (dB)
1000	22
500	27
200	33.5
50	38
20	41.5
10	44.5
5	>46
2	>46
1	>46
0.5	>46

**Figure 2**

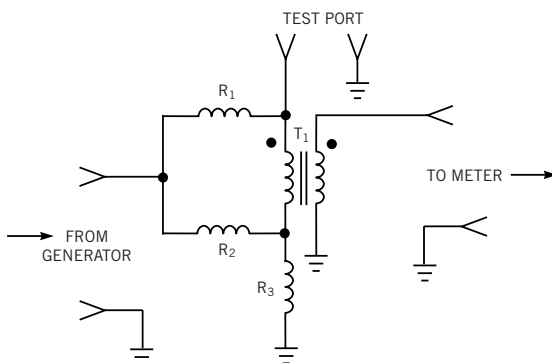

A return-loss bridge is one application for wideband, low-frequency transformers.

# μC makes effective frequency counter

Fazal Pathan, Physical Research Laboratory, Ahmedabad, India

FIGURE 1 shows an efficient and cost-effective frequency counter using an Atmel 89C2051 μC (Reference 1). The design can use any μC of the 8051 family. The circuit counts frequency and sends the count to a PC via the serial port. The signal connects to pin 3.4 of the μC. The TTL-compatible output of the μC drives the 1488, which converts the output to RS-232 voltage levels. The output

of the 1488 connects to the RxD pin on the serial port of the PC. In this design, only unidirectional communication exists between the μC and the PC. But you can use the TxD line to control another device. The assembly routine in Listing 1 shows initialization of the timer, counter, and interrupts. The main program sets up T0 to count external pulses and T1 to count time in the autoreload mode 2

(Reference 2). The main program monitors the main-program flag, frqflg, until the flag is set. Then, the main program sends the counted frequency to the PC's port using mode 1. First, it sends the special character "L" to recognize the following 3 bytes as valid data. Then it sends the value of register R2, which is the most significant byte of the counter value. This value increments every time the counter

overflows. Then, the main program sends the values of registers TH0 and TL0 to the PC's port.

After sending the data, the program

again jumps to the main routine, in which it clears the timer and counter and reinitializes them, and then starts counting again. The  $\mu$ C counts the value in

hexadecimal format; the PC can then convert it to decimal format. In this example, we used a 12-MHz crystal and a baud rate of 2400 bps. However, you can use higher clock frequencies and baud rates, because the  $\mu$ C can operate to 24 MHz. We use the system in **Figure 1** for photon counting in astronomical instrumentation. We give thanks to the Department of Space, Government of India, for material support and BG Anandarao, PhD, for encouragement. You can download **Listing 1** from EDN's Web site, [www.edn-mag.com](http://www.edn-mag.com). Click on "Search Databases" and then enter the Software Center to download the file for Design Idea #2616.

**Figure 1**

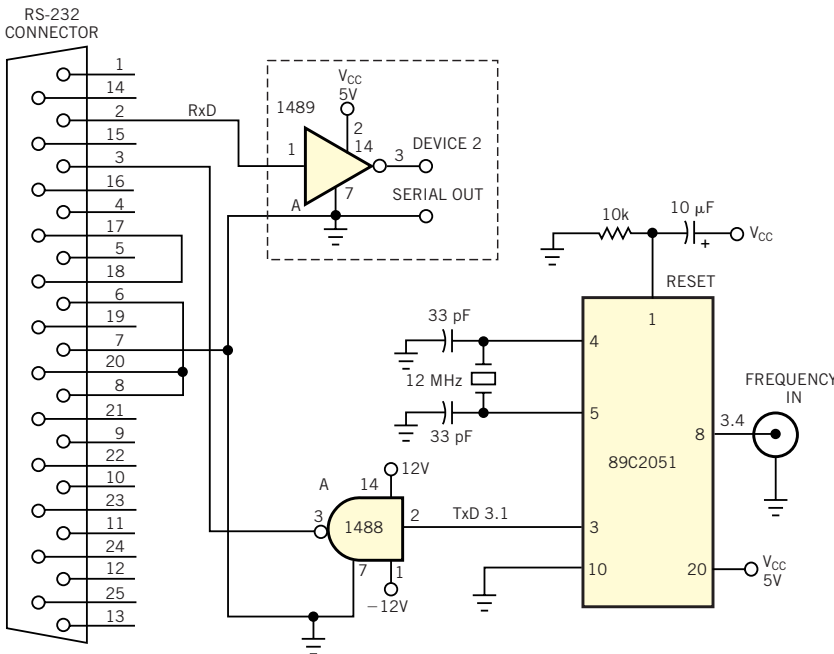

An 8051-family  $\mu$ C makes an efficient and cost-effective frequency counter.

REFERENCES

1. Data Sheet for 89C2051, [www.atmel.com](http://www.atmel.com).
2. Ayala, Kenneth J, *8051 Microcontroller: Architecture, Programming and Applications* (ISBN 0-314-77278-2), West Publishing Co, St Paul, MN.

Is this the best Design Idea in this issue? Vote at [www.edn-mag.com/edn-mag/vote.asp](http://www.edn-mag.com/edn-mag/vote.asp).

**LISTING 1—FREQUENCY-COUNTER ROUTINE FOR 89C2051**

```

; Program counts the pulses and transmits through p3.1 pin only without
handshaking signal.

;use a bit flag to signal main program
;number loaded in TH1 for 2403.8 baud

Freq:
.Equ Freqflg,0fh
.Equ Baudnum,0f3h

.Org 0000h
Mov SP, #30h
Sjmp over

.Org 000bh
Inc r2
Reti

.Org 001bh
Setb psw.3
Inc r0
Cjne r0, #00h, Checktime
Inc r1

Checktime:
Cjne r1, #27h, Goback
Cjne r0, #10h, Goback
Clr tr0
Clr tr1
Setb Freqflg

Goback:
Clr psw.3
Reti

Over:
Mov tcon, #00h
Set psw.3
Mov r0, #00h
Mov r1, #00h
Clr psw.3
Mov tmod, #25h
Mov t1l, #9ch
Mov th1, #9ch
Mov t10, #00h
Mov th0, #00h

Clr Freqflg
Mov tcon, #50h
Mov ie, #88h

Simulate:
Jbc Freqflg, Getfreq
Sjmp Simulate

Getfreq:
Anl pcon, #7fh
Anl tmod, #50h
Ori tmod, #20h
Mov th1, #Baudnum
Setb tr1
Mov scon, #40h
Mov sbuf, #'L'

Wait:
Jbc ti, Next
Sjmp Wait

Next:
Mov sbuf, r2

Wait1:
Jbc ti, Next1
Sjmp Wait1

Next1:
Mov sbuf, th0

Wait2:
Jbc ti, Next2
Sjmp Wait2

Next2:
Mov sbuf, t10

Wait3:
Jbc ti, Over
Sjmp Wait3

.End

;reset the freq. measured flag
;start timer T1 and counter T0
;enable global and T1 overflow interrupts

;have main program test "freqflg"
;loop here until freq. is measured

;set SMOD bit to 0 for Baud * 32 rate
;alter timer T1 configuration only
;set timer T1 as an 8 bit autoloader

;run T1

;set UART to model

;transmit content of the th0

;wait for T1set before next transmission
;else poll flag again

;now transmit t10
;and wait until the ti flag is set
    
```

# Software provides interrupt system for 8051

Deng Yong, Shanghai Jiaotong University, China

**B**Y USING A “PSEUDO-RETI” instruction, the program in **Listing 1** provides a three-priority-level interrupt system for the 8051  $\mu$ C. Among the three interrupt sources in the routine, External Request 0 (INT0) has the highest priority, and Internal Time/Counter 0 (IT0) has the lowest priority. In the ITO interrupt-service routine before the

“pseudo-RETI” instruction, the address of the first instruction after the “pseudo-RETI” instruction goes back into the stack. The internal nonaddressable flip-flop of the ITO clears to acknowledge a higher interrupt after execution of the “pseudo-RETI” instruction, while the ITO interrupt-service routine executes continuously until the arrival of the RETI

instruction. You can download **Listing 1** from EDN’s Web site, [www.ednmag.com](http://www.ednmag.com). Click on “Search Databases” and then enter the Software Center to download the file for Design Idea #2589.

**Is this the best Design Idea in this issue?** Vote at [www.ednmag.com/ednmag/vote.asp](http://www.ednmag.com/ednmag/vote.asp).

**LISTING 1—THREE-PRIORITY-LEVEL INTERRUPT SYSTEM FOR THE 8051**

```

ORG 0000H
LJMP START
ORG 0003H
LJMP INT0
ORG 000BH
LJMP IT0
ORG 0013H
LJMP INT1
START: MOV SP,#60H
      MOV IP,#01H           ;INT0 has high priority
      MOV TMOD,#01H
      MOV TH0,#00H
      MOV TL0,#00H
      SETB EA               ;enable INT0,INT1,IT0
      SETB EX0
      SETB EX1
      SETB ET0
      SETB TR0
      ...
INT0:  ... .....:INT0 interrupt service program

      ...
      RETI                 ;INT1 interrupt service program
INT1:  ...
      ...
      RETI
IT0:   CLR TR0             ;IT0 interrupt service program
      PUSH DPL
      PUSH DPH
      MOV DPTR,#GO_ON
      PUSH DPL
      PUSH DPH
      RETI                 ;"pseudo-RETI"
GO_ON: NOP
      ...
      MOV TH0,#00H
      MOV TL0,#00H
      POP DPH
      POP DPL
      SETB TR0
      RETI

```

# Look-up table facilitates bit flipping

Brad Bierschenk, High End Systems, Austin, TX

**I**N CERTAIN INSTANCES in embedded software, it becomes necessary to flip the order of bits in a byte, so that B7:B0 becomes B0:B7. For example, this feature could be useful with a synchronous serial port that does not allow programmed selection of bit order (MSB first or LSB first) for its shift register. If a device to which the processor sends data expects one bit order but the serial port can provide only the other bit order, you must use a software method to translate the data. One solution to this problem is to provide a look-up table in ROM, in which the value of each byte in the table is offset into the table, but with bit order reversed. In other words, the first byte is offset 0 (00000000b), the second byte is offset 1 (10000000b), the third

**LISTING 1—CODE SEGMENT FOR 80XC51 ARCHITECTURE**

```

; Load value into accumulator (hex AA)
mov  A, #10101010b
; Load lookup table address into index
mov  DPTR,#InvertTable
; Load "flipped" value into accumulator
movc A,@A+DPTR
; Accumulator should now hold hex 55

```

byte is offset 2 (01000000b), and so on. The program merely needs to load the value to be translated into a register that can serve as an offset, index the look-up table, and load the corresponding value from the index+offset location. This design uses the Philips 80xC51 architecture as an example. **Listing 1** shows a code segment for the  $\mu$ C. You can use the  $\mu$ C’s 16-bit DPTR (data pointer) plus an 8-bit

offset in its accumulator to load the accumulator with a byte value. This solution to bit flipping is dynamically more efficient than rotating a byte location through carry bits or other possible solutions. However, it’s not the most statically efficient solution, because it requires 256 bytes of ROM for the look-up table. You can download **Listing 1** and the look-up table from EDN’s Web site, [www.ednmag.com](http://www.ednmag.com). Click on “Search Databases” and then enter the Software Center to download the file for Design Idea #2621.

**Is this the best Design Idea in this issue?** Vote at [www.ednmag.com/ednmag/vote.asp](http://www.ednmag.com/ednmag/vote.asp).