

# leading edge

What's hot  
in the  
design  
community

Edited by  
Fran Granville

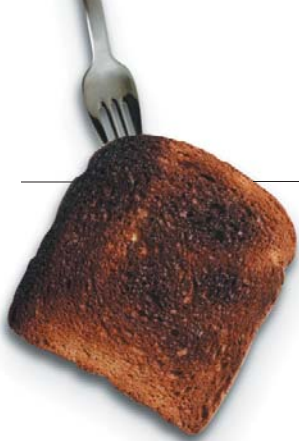

**Stick a fork in it**  
**"My interest in**  
**things electrical**  
**began at age three**  
**when I stuck a fork**  
**into a toaster and**  
**got a nasty—and**  
**presumably excit-**  
**ing—shock!"**

**—Steve Woodward,**  
**EDN contributor**  
**and free-lance technology**  
**consultant**

## Video-capture card drives multiple displays

By Warren Webb

**C**URTISS-WRIGHT CONTROLS Embedded Computing recently launched a high-resolution PCI Mezzanine Card graphics-display controller

and video-capture card for VME, CompactPCI, and PCI systems. The Topaz/PMC, powered by Silicon Motion's 128-bit SM731 graphics accelerator, supports screen resolutions as high as 1600×

1200 pixels and includes 16 Mbytes of high-speed display SDRAM to provide local storage for image and off-screen data, such as texture maps, Z-buffers, and backing storage. The card can output a

range of graphics and video formats and interface types, including single- and dual-channel analog and LVDS and single-channel DVI and Stang 3350. Supported analog interlaced formats include RS-170, PAL, NTSC, and S-Video. Video inputs include noninterlaced, interlaced, and DVI formats. According to Victor Gold, Curtiss-Wright vice president, the low-cost graphics card meets the majority of nonrugged graphics applications. With an operating temperature range of 0 to 70°C, the Topaz/PMC supports Linux, LynxOS, Windows, and VxWorks operating environments. Prices start at \$750 (single quantities).

►Curtiss-Wright Controls Embedded Computing, [www.cwembedded.com](http://www.cwembedded.com).



The Topaz/PMC card combines VGA/LVDS/DVI graphics with video, DVI, and RGB digitizers.

## Wireless PC/104-Plus module links industrial nodes

WINSYSTEMS' NEW PPM-Wireless module provides industrial users with a high-speed data network based on Mini-PCI 802.11b/g wireless modules and Ethernet. The module allows designers to replace a standard Category 5 Ethernet cable with a radio channel that simplifies cabling installation and configuration issues. With many of the features and functions of a normal PCI card but at about one-quarter the size, the 90×96-mm, PC/104-Plus-compliant module has onboard interface electronics and a MiniPCI connector. Mini-PCI cards suit use in mobile applications.

WinSystems ships the PPM-Wireless with an empty Mini-PCI socket or with an Intel Pro/Wireless 2200BG Mini-PCI card. The

Wi-Fi-certified Intel 2200BG module delivers channel speeds as high as 54 Mbps and maintains full backward compatibility with 802.11b networks. The 2200BG network connection also supports security standards, such as WPA (Wi-Fi Protected Access), and users can upgrade it using software downloads for future security standards, such as 802.11i, when it becomes available.

Typical indoor range is 100 ft at 54 Mbps or 300 ft at 1 Mbps, but it depends on which MiniPCI module you use and the system's antenna type and placement. Delivery is from stock to three weeks, and prices start at \$149 without the Mini-PCI module.

—by Warren Webb

►WinSystems, [www.winsystems.com](http://www.winsystems.com).



The PC/104-Plus PPM-Wireless module from WinSystems delivers 802.11b/g wireless-Ethernet connectivity for industrial applications.

## Video processor embraces high-speed A/V link

**A**T LAST YEAR'S CONSUMER ELECTRONICS SHOW, Silicon Image rolled out a three-chip transmitter-and-receiver family supporting the HDMI (high-definition-multimedia-interface) audio-plus-video interface it pioneered. This year, the company takes HDMI in an even more integrated

integrated direction, embedding an HDMI receiver within its \$13.95 (10,000) SiI 8100 video processor (see "Digital-multimedia interface grows up," *EDN*, Jan 22, 2004, pg 22). Targeting direct-view digital TVs, such as LCD- and CRT-based units, the SiI 8100 also supports high-definition RGB and component-video inputs to bridge the analog-to-digital transition, along with a standard-definition ITU-R BT.656 video-input port. Output options include a 10-bit triple DAC (with 8- to 10-bit gamma expansion as necessary) for RGB and component video, an 18- or 24-bit TTL (RGB) driver, and a dual-channel LVDS transmitter.

Silicon Image calls the SiI 8100 a *processor*, though, not just a signal shuttler. What goes on between the chip inputs and outputs? The device can bicubically scale incoming images to television resolutions of as many as 1920×1080 pixels (interlaced) and to PC-graphics resolutions reaching SXGA (1280×1024 pixels at 75 Hz). It can also adaptively stretch 4-to-3 aspect-ratio inputs to a 16-to-9 ratio and eliminate moiré. It converts 50-Hz video to 60 frames/sec, tackles interlaced-to-progressive-scan conversion (including inverse 2-to-2 and 3-to-2 pull-down), and creates picture-in-picture displays. Other video-processing

capabilities include white- and black-level expansion; dark- and gray-area UV suppression; hue, saturation, brightness, and contrast controls; RGB-to-component-video and component-video-to-RGB color-space conversion; and PC-compliant RGB-color adjustments.

What about the audio coming in over HDMI? The SiI 8100 extracts it, which is not a trivial function; don't forget that, as part of this task, the SiI 8100 implements HDMI's HDCP (High-bandwidth Digital Content Protection) scheme for both audio and video. The SiI 8100 then passes it on, over both S/PDIF and I<sup>2</sup>S outputs, to other system circuitry for processing and playback. Silicon Image has scheduled availability of sample units, which will come in a 256-pin LQFPs, for April, with volume production following in June.

—by Brian Dipert

► **Silicon Image**, 1-408-616-4000, [www.siliconimage.com](http://www.siliconimage.com).

### DMM PUTS 7½ DIGITS INTO PCI PLATFORM

The Signametrics SM2064 digital multimeter puts high precision into a PCI plug-in form, well-suited for test-system integrators and instrumentation users. Featuring measurement rates to 20,000 readings/sec without latency, the unit has resolution as low as 10 nV; the lowest current measurement is 50 pA.

In addition to basic voltage and current measurements, it can perform six-wire ohm readings, inductance and capacitance readings, frequency and timing measurements, and thermocouple/resistance-temperature-detection measurements. It also functions as a voltage or current source and a pulse and pattern generator.

The vendor offers front-panel-equivalent software, DLLs for Windows OS, and Linux drivers. The \$2395 unit may have more functions than you need, so Signametrics offers the basic SM2064 unit, still with the same precision specifications but 1400 readings/sec, for \$1595.—by Bill Schweber  
► **Signametrics Corp**, 1-206-524-4074, [www.signametrics.com](http://www.signametrics.com).

## DILBERT *By Scott Adams*



► Microsoft's Windows CE operating system accounted for 48.1% of the third quarter's 2.8 million PDA shipments worldwide, up from 41% the previous year, according to market researcher Gartner Inc.

# Consumer-tuned chips exemplify integration trend

AS A GIVEN APPLICATION increases in popularity, system shipments rise, competition emerges, and cost pressures consequently increase, Moore's Law inexorably comes into play. Chip vendors at the core of the system design pull functions that formerly resided in separate peripherals into their next-generation products. These core semiconductor suppliers also expand the overall capabilities of their products and thus the ability for their customers to differentiate themselves from their competition.

LSI Logic's DiMeNtion-3 chip set exemplifies the many-into-one trend, responding to the emergence of less-than-\$150 DVD recorders and the high likelihood of further price declines in the future, which today's less-than-\$50 DVD players forecast. The three-chip combination of the DMN-8603 system processor, the L3200 servo and analog-front-end device, and either the L2146 or the L2150 NTSC/PAL analog-video decoder delivers a DVD-re-

recorder bill-of-materials cost \$40 less than its 2002 equivalent, according to Consumer Products Marketing Manager Jim Fox. Some of this cost savings comes from multichip-to-single-chip feature integration; the remainder comes from the conversion to a unified flash-plus-DRAM subsystem versus the multiple redundant volatile- and non-volatile-memory arrays of past system architectures.

The DMN-8603 delivers comprehensive features: format flexibility to support DVD-RAM, DVD-RW/-R, and DVD+RW/+R, including dual-layer-writing optical discs; DivX and MPEG-4 encoding and decoding support; Super Audio CD and DVD-audio decoding for universal player designs; standard-definition-upconversion and high-definition JPEG decoding; simultaneous 480-line interlaced and progressive-scan analog-video outputs; and YesDVD Version 2.0 support (see "DVD controllers deliver the write options," *EDN*, Jan 22,

2004, pg 18). The entry-level L2150 includes 9-bit video ADCs and comes in a 32-pin TQFP; the more advanced L2146 upgrades the ADCs to 10-bit resolution, supports both RGB and component-video inputs, and comes in an 80-pin TQFP. The three-chip DVD-recorder set costs \$25 (1 million); LSI Logic has no plans to separately sell each chip.

Analyze the generation-to-generation integration of TI's imaging processors, and you get a fairly accurate forecast of future audio-processor trends (see "Imaging competitors choose divergent paths to a nebulous destination," *EDN*, March 18, 2004, pg 20). TI supplements the 192-MHz c55x DSP core of the previous-generation TMS320DA-DA250 and smaller process DA255 with an 84-MHz ARM7TDMI CPU core to construct the \$11.95 (100,000) TMS320DADA295 (see "Processor vendors hope to get an 'arm up' on the competition," *EDN*, Nov 23, 2000, pg 28). The ARM core off-

loads the DSP from some of the system-control functions that the DSP previously had to handle, enabling the c55x to focus on the multimedia tasks it best manages.

The ARM7TDMI also acts as a multimedia coprocessor as necessary. With iPod photos in mind, TI is touting the DA295's ability to decode JPEG images at 1 million-pixel/sec rates. (Note: This performance estimate does not include postprocessing.) The company also touts the DA295's ability to handle MPEG-4 simple-profile streams at QCIF frame sizes but unspecified frame rates. The company plans for the DA295 to be available in sample quantities by the end of the first quarter of 2005, with production slated for the third quarter. A \$20,000 production-ready reference design, including all necessary software, will also be available in the second quarter.—by Brian Dipert

► **LSI Logic**, [www.lsillogic.com](http://www.lsillogic.com).

► **Texas Instruments**, 1-972-995-2011, [www.ti.com](http://www.ti.com).

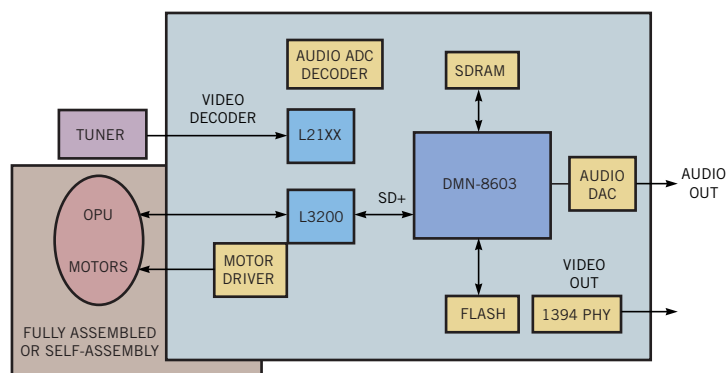

(a)

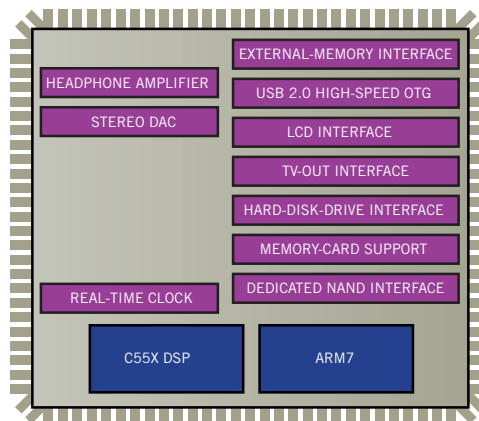

(b)

LSI Logic's DiMeNtion-3 chip set (a) and Texas Instrument's TMS320DADA295 (b) are case studies for the degree of integration necessary in high-volume consumer-electronics applications.

► Laptop makers equipped some 79% of their products sold in 2004 with built-in wireless connections, and that number will rise to nearly 100% this year, according to Instat/MDR.

# Graphics-memory-management scheme resurrects, advances past initiative

**W**HEN INTEL BEGAN, in the late 1990s, championing the AGP (accelerated graphics port), one commonly touted capability was AGP Aperture mode—that is, the ability to employ system memory as part or all of the graphics card’s frame buffer. Intel’s i740 graphics accelerator supported AGP Aperture mode, as did a series of 3Dlabs chips whose Virtual Texturing feature the company also implemented over PCI (see “Make way for the graphics Goliath,” *EDN*, March 13, 1998, pg 12). And some integrated graphics cores within core-logic chip sets from Intel and others, which connect to the remainder of the core-logic circuitry over an internal AGP bus, also implement AGP Aperture mode.

However, aside from the earlier cited Intel and 3Dlabs examples, discrete graphics chips have not widely adopted AGP Aperture mode. Part of the reason is memory performance: Cost-focused main memory has slower peak and sustained transfer rates than graphics-tuned DRAM. Part of the reason is system-performance overhead: An intermediary AGP-plus-core-logic bottleneck between the graphics chip and the main memory increases latency, and AGP 1.0 implementations offered only 266-Mbyte/sec downstream transfer rates from main memory to the graphics subsystem. (The latest generation AGP 8x delivers 2.133-Gbyte/sec peak

downstream speeds.) Also, all AGP variants support only PCI-derived, 266-Mbyte/sec peak upstream speeds from the graphics subsystem to main memory, thereby explaining why vendors have limited AGP Aperture mode use to mostly one-way, downstream applications, such as texture caching. And part of the reason for that restriction is cost; although graphics-tuned memory is more expensive than main memory on a cost-per-megabyte basis, it has still benefited from the downward DRAM-price spiral of recent years. Why hassle with the implementation issues of AGP Aperture mode when, for a minor increment in cost, you can simply increase the size of the local frame buffer on the graphics board?

That said, a minor increment in cost is still something more than “no cost,” and profit-squeezed chip and board manufacturers are looking to slash expenses from the bill-of-materials equation whenever and wherever they can. So it is, then, that Nvidia has revisited the concept of main memory as graphics memory



**Low-end GeForce 6200 clock rates enable passive cooling on the \$79 TurboCache variant.**

with its GeForce 6200 TurboCache products, as competitor ATI Technologies will also do with its upcoming HyperMemory line. What’s changed to make the concept more feasible this time around? In two words: PCI Express. Each serial PCI Express Version 1 link is capable of *full-duplex*, 250-Mbyte/sec peak transfer speeds. A 16-bit PCI Express bus between core logic and the graphics accelerator can theoretically, therefore, simultaneously receive and transmit 4 Gbytes/sec of instructions and data. First generation Intel PCI Express implementations in the i915 and i925 core-logic chip sets provide only 3-Gbyte/sec downstream and 1-Gbyte/sec upstream speeds, but subsequently introduced chip sets

from Intel should improve in this area, as do chip sets from Nvidia and other suppliers. Keep in mind, too, that “PCI Express Aperture Mode” implementations are more complicated with AMD CPUs than Intel microprocessors because AMD Athlon 64, Opteron, and Sempron processors integrate the DRAM controller, thereby potentially creating incremental overhead between main memory and graphics subsystem versus in the Intel-based case.

Nvidia plans at least three desktop-PC-targeted TurboCache variants of Nvidia’s GeForce 6200 graphics processor, a four-pixel-pipeline spin-off of the GeForce 6800 (see “Graphics advancements

span PCs to cell phones,” *EDN*, June 24, 2004, pg 14). A \$79 board employs the 32-bit local-memory-interface version of the 350-MHz GeForce 6200; contains a 16-Mbyte, 350-MHz DDR frame buffer; and addresses as much as 128 Mbytes of memory, including system memory. For \$99, you get a 64-bit interface to 32 Mbytes of local frame buffer, and, for \$129, you get 64 Mbytes of local frame buffer—again over the 64-bit memory-bus option—and the ability to access as much as 256 Mbytes of graphics memory.

Will TurboCache “fundamentally redefine the price/performance of entry-level PCs,” as Nvidia’s marketers tout, or will it be nothing more than “TurboCash,” a means by which Nvidia can improve its chip profit margins at a given retail price point by removing graphics memory from the board? Time will tell; competitive price pressure and the comparable pricing of previous generation Nvidia boards with larger local frame buffers will both play a part in TurboCache’s success, along with the degree to which consumers long trained in a bigger-is-better frame-buffer mantra embrace the revised TurboCache pitch. Nvidia also plans power-optimized GeForce Go 6200 TurboCache parts for notebook PCs; in this application, the TurboCache-memory-budget concept has a greater likelihood of success.

—by Brian Dipert  
►Nvidia, 1-408-486-2000, [www.nvidia.com](http://www.nvidia.com).

# Credit a fork's shorting the toaster: Q and A with Steve Woodward

By Warren Webb, Technical Editor

WITH MORE THAN 30 contributions to his credit, Steve Woodward is one of *EDN's* most prolific Design Ideas authors. His offerings started in 1974 with an idea entitled "Simple 10-kHz V/F features differential inputs," for which he won the annual prize for the best Design Idea. As a self-proclaimed "certified, card-carrying analog dinosaur," most of Woodward's ideas solve issues in that nebulous "nondigital" area of design engineering that gives us the thorniest problems. His Design Idea titles, such as "Self-heated transistor digitizes airflow" in 1996 and "Circuit controls microneedle etching" in 2003 demonstrate how he likes to adapt electronics to the physical world.

Woodward is an instrumentation, sensors, and metrology free-lance consultant to organizations such as Agilent Technologies, The Jet Propulsion Laboratory, the Woods Hole Oceanographic Institute, Catalyst Semiconductor, Oak Crest Science Institute, and several international universities. With six patents to his credit, he has authored more than 160 professional articles. He has also served as a member of technical staff at the University of North Carolina. He lives with his wife, Clare, and sons in Chapel Hill, NC.

**EDN:** *When you were growing up, what got you excited about technology, and where did you learn engineering?*

**Woodward:** I'm told by my mother that my interest in things electrical began at age three when I stuck a fork into a toaster and got a nasty—and presumably exciting—shock! But then Mom is known for "creative" stories. Truthfully, I can't remember a time when I wasn't fascinated by technology—both real and fanciful. Issac Asimov was my favorite author—for obvious reasons.

I was born in Fort Smith, AK, moved to California in 1960, and received my high-school and undergraduate-college education in the LA area. I got a BSE (cum laude) from CalTech, Class of '68. I then moved to Chapel Hill, NC, for grad school (master's degree in computer science in 1970), and here we are still today.

**EDN:** *What are you working on now, and what is your biggest technical challenge?*

**Woodward:** Actually, a recently published *EDN* Design Idea comes from a current project to help develop a space-flight-capable, self-contained, tunable diode-laser spectrophotometer.

Such projects entail many design challenges with their requirements for low power consumption and endurance of environmental extremes. But one of the hardest is to confine component selection to existing lists of certified-space-capable, preferred components.

The process of flight certification of components is an expensive and lengthy process and is funded only spottily and—primarily—by individual instrument development projects. As a result, the components that appear in these lists—for example, the NPSL [NASA Parts Selection List] have typically been there for a long time. They're therefore often quite obsolete.

[Consider] the constraints of weight and power consumption already imposed by design for planetary exploration. Imposing the additional fiscal one of needing to design with older parts to avoid the large expense of qualifying newer ones outside the budget of the project can make an engi-

neer's life very interesting indeed.

**EDN:** *Has your work been affected by the trend toward outsourcing engineering talent?*

**Woodward:** Well, as a free-lance consultant, I'm one of those "outsources." So, I guess I'd happily say "yes."

**EDN:** *What do you do for fun?*

**Woodward:** I enjoy spending time with my family, swimming, shooting, and generalized tinkering. I'm also a private pilot, and you may see me flying around the Chapel Hill skies in a Piper Cherokee Warrior.

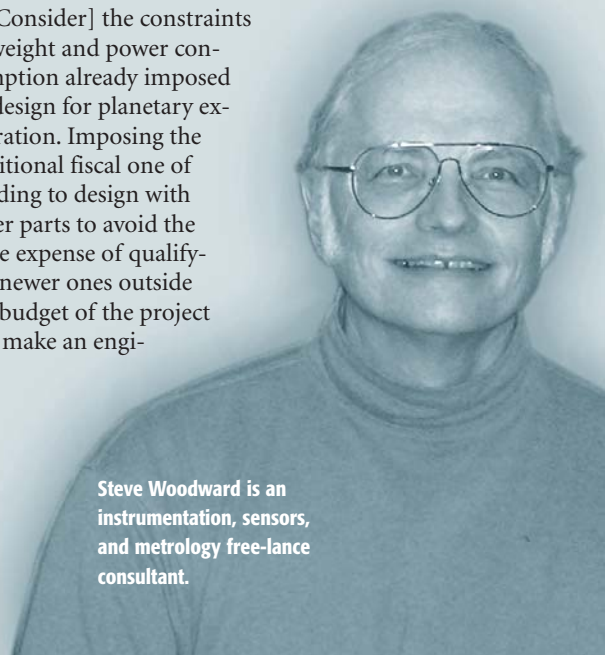

Steve Woodward is an instrumentation, sensors, and metrology free-lance consultant.

► The number of electronic-payment transactions reached 44.5 billion in 2003, according to a study by the Federal Reserve. Checks were still the single largest noncash payment type in 2003, however, with the total number at 36.7 billion. That figure compares with 30.6 billion electronic payments and 41.9 billion checks paid in 2000, the last year for which the Fed has similar data.