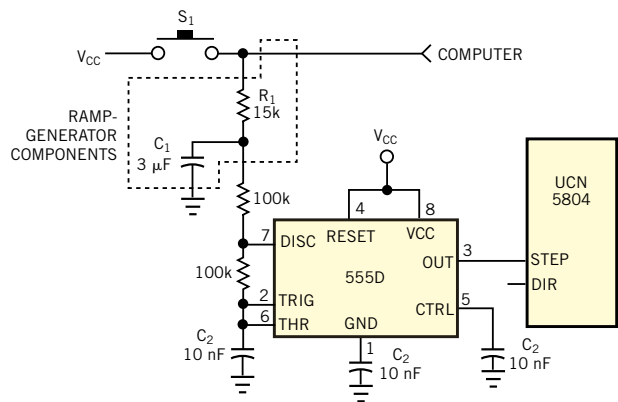

Figure 1



This circuit generates a pseudo-trapezoidal motion-control profile for controlling stepper motors.