

# design ideas

Edited by Bill Travis

## Oscillating output improves system security

Jorge Marcos and Ana Gómez, University of Vigo, Vigo, Spain

**M**ANY ELECTRONIC-CONTROL systems have digital outputs that use transistors. One method of improving the security in these outputs is to use an oscillating signal to represent a logic-high state instead of a fixed voltage level (**Figure 1**). This type of signal, a *dynamic variable*, can drive the circuit shown in **Figure 2**. This circuit connects to the output transistor of the electronic-control system. The dynamic-variable signal connects to the output transistor, whose collector connects to a pulse transformer. If the system cannot produce pulses because of a fault, the relay deactivates. If a fault exists in the drive circuitry, the output system stays off. This solution guarantees the security function when one fault occurs. However, it does not guarantee the detection of all faults. However, you can use a DPDT relay and connect one of the contacts to one of the electronic-control inputs; thus, you can confirm the relay's activation or deactivation in the control program.

The circuit in **Figure 2** performs efficiently if the system can generate a frequency greater than 1 kHz to excite the

**Figure 1**

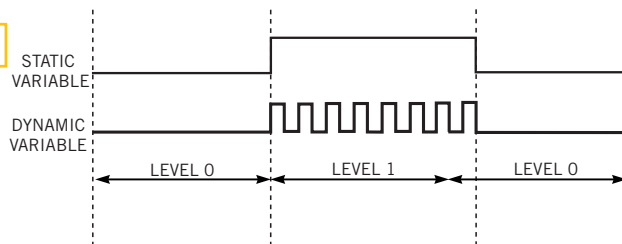

You can improve the reliability of an electronic-control output by using an oscillating, instead of steady-state, signal to represent a logic-high state.

**Figure 2**

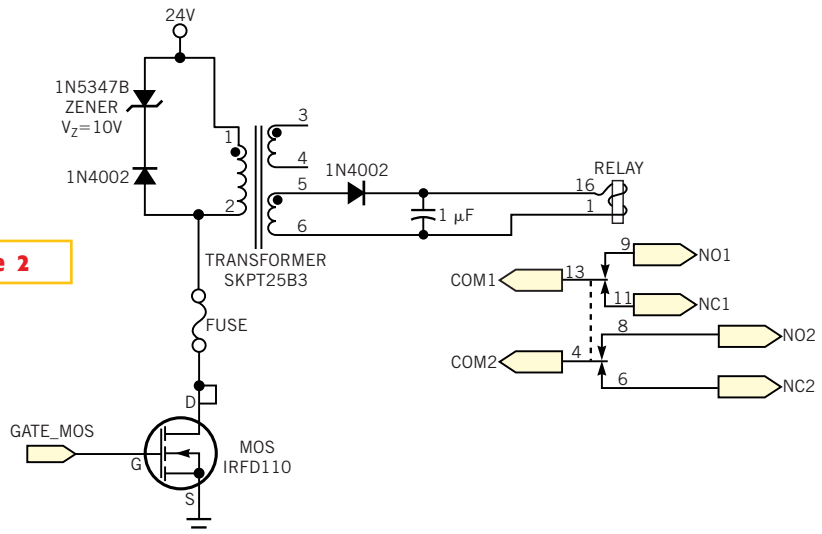

A "dynamic-variable" signal drives the output relay in this circuit.

pulse transformer. Many electronic systems that use an output transistor can generate a dynamic variable. Many systems, such as PLCs (programmable-logic controllers), have long cycle times and, thus, cannot generate signals of adequate frequencies. In these cases, you can obtain an appropriate signal using the low-frequency dynamic variable from the PLC. To accomplish that task, you must use an external oscillator and a pulse detector implemented with a monostable multivibrator. The oscillator produces a

square-wave signal of a frequency that suits commercial pulse transformers. This signal drives the MOSFET when the pulse detector receives pulses from the PLC. Because the pulse detector can fail, you must duplicate the external circuit for redundancy. In this way, the final result is the same as that of **Figure 2**, except that the safe output comprises two relays.

Is this the best Design Idea in this issue? Select at [www.edn.com](http://www.edn.com).

Oscillating output improves system security.....	85
Polarity protector outperforms Schottky diodes.....	86
Circuit offers improved active rectification.....	86
Build an adjustable high-frequency notch filter.....	90
Bootstrapping allows single-rail op amp to provide 0V output.....	92
Filter allows comparison of noisy signals.....	94
<b>Publish your Design Idea in EDN. See the What's Up section at <a href="http://www.edn.com">www.edn.com</a>.</b>	

# Polarity protector outperforms Schottky diodes

Mike Hovenga, BAE Systems, Austin, TX

**T**HE POLARITY-PROTECTION circuit in **Figure 1** is a high-performance alternative to the usual series diode (often Schottky). The circuit incurs a much lower voltage drop than even the best Schottky diode. The circuit uses

MOSFET devices because of their low on-resistance. For the transistors in this design, the combined on-resistance is  $0.013\Omega$ . With a 10A load, the voltage drop is 0.13V at 25°C. Compare this figure with forward-voltage drops of several hundred millivolts for Schottky diodes under the same conditions. You must use p- and n-channel transistors in series because of their intrinsic diodes. A photo-voltaic isolator provides the appropriate gate drive to the MOSFETs. The performance is even better at lower currents. You can replace the two discrete transistors by a single-package, complementary-MOSFET pair, such as an IRF7389, which has a combined on-resistance of  $0.108\Omega$ . Resistors  $R_2$  and  $R_3$  are necessary to turn off the transistors when  $IC_1$  turns off.  $R_1$  provides a nominal 12V input.

**Figure 1**

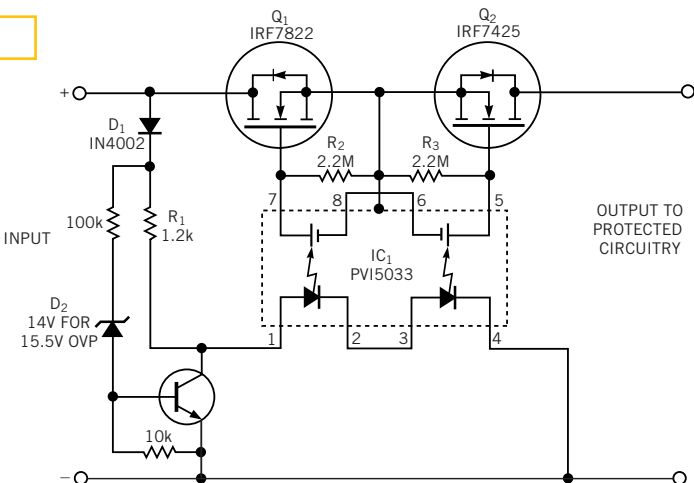

This polarity-protection circuit incurs lower forward-voltage drop than the best Schottky diodes.

Is this the best Design Idea in this issue? Select at [www.edn.com](http://www.edn.com).

# Circuit offers improved active rectification

Reza Moghimi, Analog Devices Inc, San Jose, CA

**R**ECTIFIERS CONVERT ac signals to dc. You can combine a diode and a load resistor to

**Figure 1**

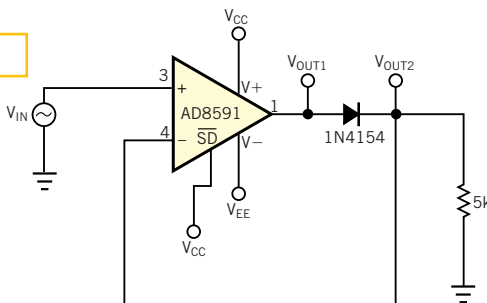

This circuit is a typical half-wave-rectifier configuration.

create a half-wave rectifier, provided that the amplitude of the ac source is much larger than the forward drop of the diode (typically 0.6V). Unfortunately, you can't use this method to rectify signals that are smaller than a diode drop. For these applications, active rectifiers using amplifiers are available. The diode is inside the feedback loop of an amplifier (**Figure 1**). For  $V_{IN} > 0V$ , the diode provides negative feedback, and the output,  $V_{OUT2}$ , follows the input ( $V_{OUT2} = V_{IN}$ ). For  $V_{IN} < 0V$ , the diode does not

conduct, the amplifier is in an open-loop configuration, and  $V_{OUT2} \sim 0V$ . **Figure 2** shows the response of the circuit in **Figure 1**. The output is shown in green; the

input is shown in red.

If  $V_{IN} < 0V$ , the amplifier behaves as a comparator. Its negative input is at a higher potential than its positive input, so its output,  $V_{OUT1}$ , saturates to  $V_{EE}$ . When the input again becomes positive, the amplifier has to recover from saturation and respond as quickly as its slew rate and saturation recovery time allow. This response takes some time, and the input may have changed by the

time the amplifier is ready to respond to the positive input. The signals at  $V_{OUT1}$  (red) and  $V_{OUT2}$  (green) clarify this point (**Figure 3**).  $V_{OUT2}$  is the same waveform as

in **Figure 2**. Note the change in scale factor.  $V_{OUT1}$  is a diode drop higher for positive inputs and saturates to  $V_{EE}$  for negative inputs. The time delay in the response may result in a significant error in the output.

For example, an amplifier that has a slew rate of  $2.5V/\mu\text{sec}$  and saturates to  $-2.5V$  takes at least  $1\ \mu\text{sec}$  to get ready to respond to positive inputs. During this time, the fast input has changed, so rectification starts at the wrong part of the input. One way to minimize this error is to use a high-slew-rate amplifier, but this solution comes at the expense of high power consumption. Another option is to use an inverting-amplifier configuration and two diodes, followed by a unity-gain inverting amplifier to obtain the noninverting rectification. This method appears in many textbooks. The circuit in **Figure 4** represents a one-stage, noninverting rectifier that improves the accuracy of the rectification and reduces the power consumption. In this circuit, an AD8561 amplifier acts as a comparator. The AD8591 performs the rectification.

When  $V_{IN} > 0V$ , the output of the AD8561 is high, and the AD8591 acts as a follower. When  $V_{IN} < 0V$ , the output of the AD8561 is low, and the AD8591 shuts down. This shutdown puts the output of the AD8591 into a high-impedance state, so it remains at approximately  $0V$ , rather than saturating to  $V_{EE}$  as it did in the previous circuit. When  $V_{IN}$  goes positive, the amplifier comes out of shutdown and again follows the input. This turn-on time (the time it takes to come out of shutdown) is much shorter than the saturation recovery time and slew-rate limiting that occurs in the previous circuit. **Figure 5** shows the signals at the input (red) and output (green) of the improved rectifier circuit.

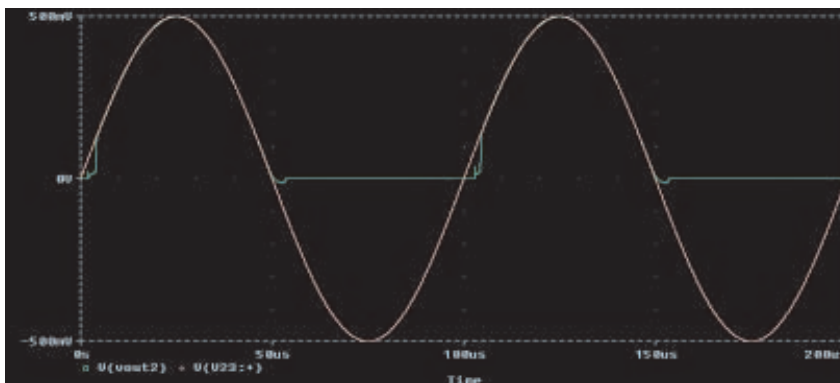

**Figure 2** These signals appear at the input (red) and the output (green) of the circuit in Figure 1.

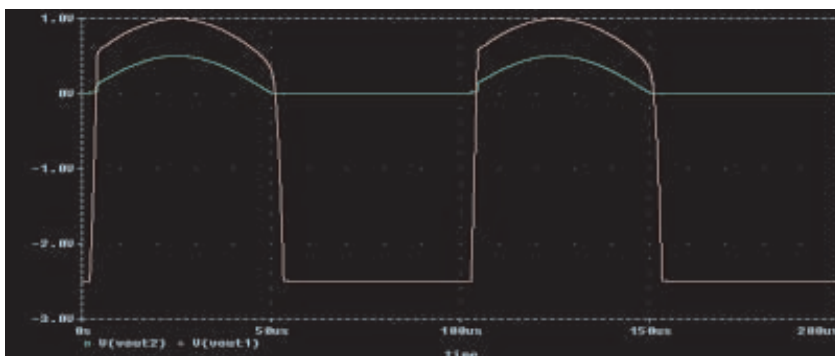

**Figure 3** These signals are the waveforms at  $V_{OUT2}$  (green) and  $V_{OUT1}$  (red) in the circuit in Figure 1.

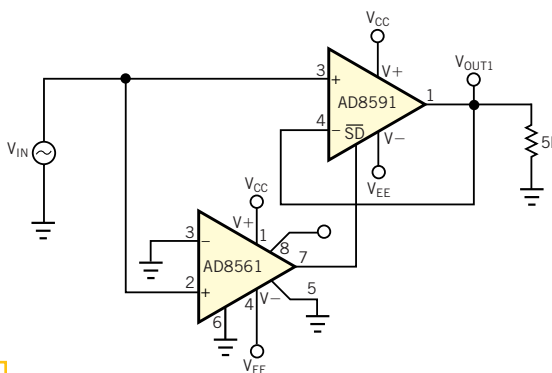

**Figure 4** This circuit greatly improves on the performance of the circuit in Figure 1.

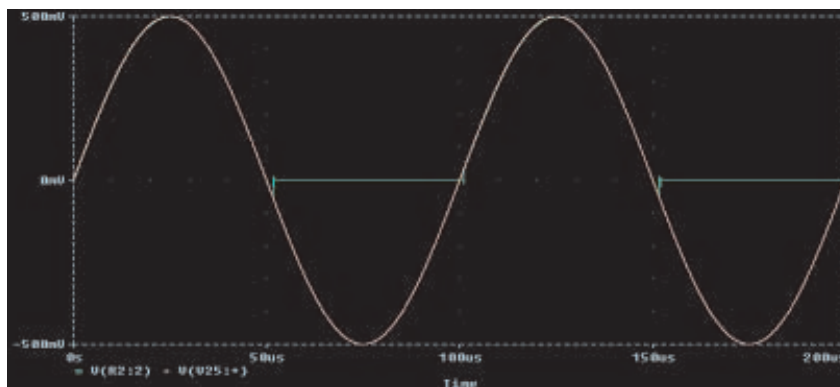

**Figure 5** These signals appear at the input (red) and output (green) of the circuit in Figure 4.

Is this the best Design Idea in this issue? Select at [www.edn.com](http://www.edn.com).

# Build an adjustable high-frequency notch filter

John Ambrose, Mixed Signal Integration Corp, San Jose, CA

**A**LTHOUGH YOU CAN obtain universal, resistor-programmable switched-capacitor filters that are configurable as notch filters, most cannot operate at bandwidths higher than 100 kHz. Further, the typically 16- to 20-pin packages do not include a continuous-time, antialiasing filter to prevent spurious signals from appearing at the output. By using an eight-pin, dual operational amplifier and an eight-pin, switched-capacitor

bandpass filter, you can construct a notch filter (Figure 1). IC<sub>2</sub>, a TLC082 is a dual BiCMOS op amp, replacing the older JFET-input stage with lower noise CMOS but retaining the bipolar output for high drive capability. The gain-bandwidth product of the TLC082 is 10 MHz, allowing you to use it for filtering at frequencies as high as 1 MHz. The minimum ( $V_{CC} - V_{EE}$ ) span with the TLC082 is 5V, unlike the older TL082, which re-

quired 6V. This supply span matches well with IC<sub>1</sub>, an MSHFS6, with its 5V nominal operating voltage. Using half of the TLC082, you can construct a third-order, elliptic lowpass filter.

You set the passband ripple at approximately 5 dB to increase the out-of-band rejection. You set the continuous-time filter for 800 kHz, providing greater than 40 dB of rejection at 12.5 MHz. Figure 2 shows the frequency response of the

Figure 1

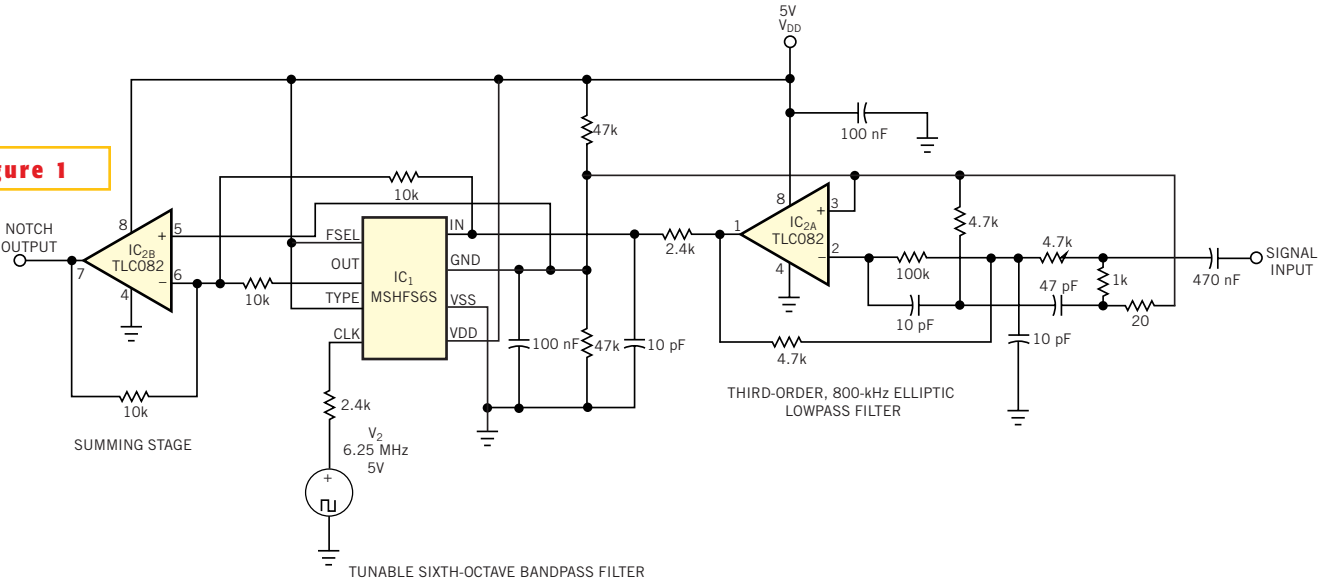

An op amp and a switched-capacitor filter combine to form a highly selective notch filter.

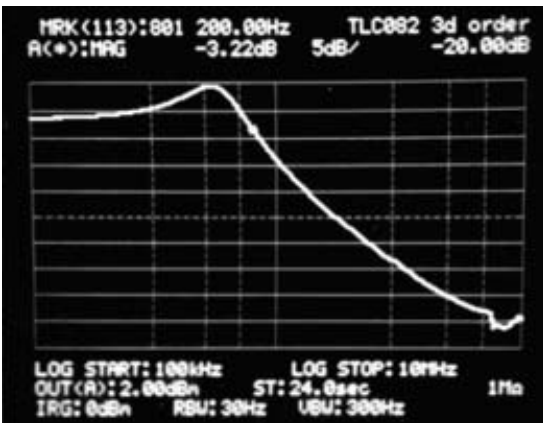

Figure 2

This plot is the frequency response of the third-order lowpass-filter stage.

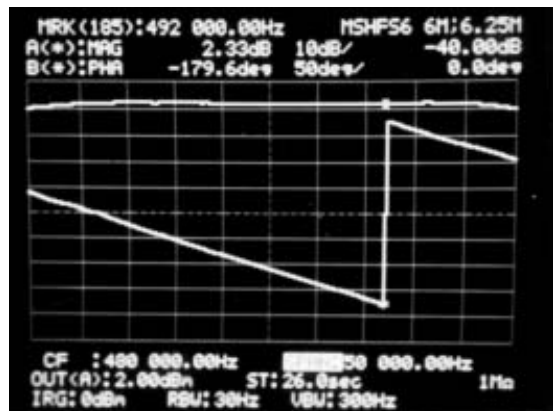
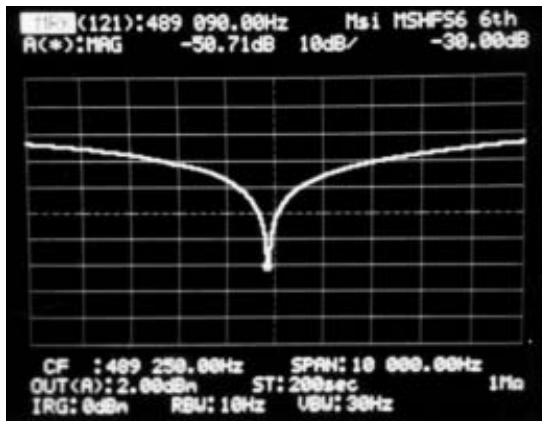

Figure 3

This Bode plot represents the passband of the MSHFS6 filter.

third-order lowpass filter using the TLC082. The MSHFS6 switched-capacitor selectable lowpass/bandpass filter with its 12.5-to-1 clock-to-corner ratio allows for distortion measurements to 6.25 times the notch center frequency before aliased signals cause measurement error. With the TLC082 lowpass filter set at 800 kHz, you can measure distortion products as high as the third harmonic. If the notch center frequency is always set lower than 260 kHz (MSFS6 clock at 3.3 MHz), then you can set the continuous-time lowpass filter corner to a lower frequency by adjust-



**Figure 4**

The circuit in Figure 1 delivers a  $-50$ -dB notch.

ing the resistor and capacitor values. By summing the output of the bandpass filter with the input, cancellation of the input signal occurs at  $180^\circ$  phase shift in the passband. **Figure 3** shows the Bode plot of the passband of the MSHFS6 sixth-octave filter setting. The output of the other half of the TLC082 provides the notch-filter output. **Figure 4** shows the depth of the notch filter at  $-50$  dB.

Is this the best Design Idea in this issue? Select at [www.edn.com](http://www.edn.com).

## Bootstrapping allows single-rail op amp to provide 0V output

Jim Williams, Linear Technology Corp, Milpitas, CA

**M**ANY SINGLE-SUPPLY-POWERED applications require amplifier-output swings within 1 mV—or even submillivolts—of ground. Amplifier-output-saturation limitations normally preclude such operation. **Figure 1**'s power-supply bootstrapping scheme achieves the desired characteristics with minimal parts count. IC<sub>1</sub>, a chopper-stabilized am-

plifier, features a clock output. This output switches Q<sub>1</sub>, providing drive to the diode-capacitor charge pump. The charge pump's output feeds IC<sub>1</sub>'s V<sub>-</sub> terminal, pulling it below 0V, thus permitting an output swing to and below ground. In **Figure 2**, the amplifier's V<sub>-</sub> pin (Trace B) initially rises at supply turn-on but heads negative when ampli-

fier clocking commences at approximately midscreen. The circuit provides a simple way to obtain output swing to 0V, allowing a true "live-at-zero" output.

Is this the best Design Idea in this issue? Select at [www.edn.com](http://www.edn.com).

**Figure 1**

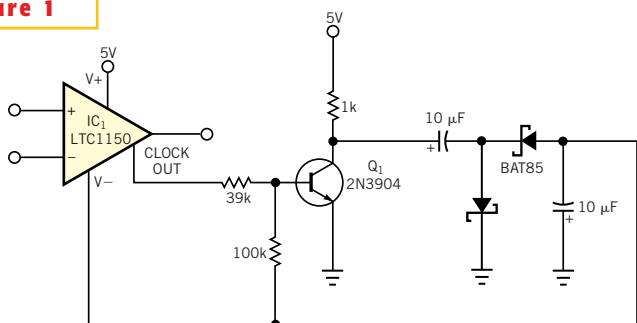

This configuration uses bootstrapping to allow a single-rail op amp to operate at 0V output.

A=5V/DIV

B=0.2V/DIV

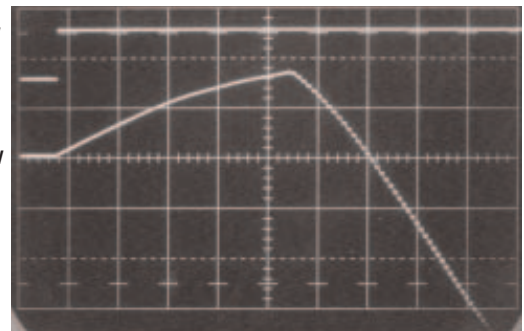

5 mSEC/DIV

**Figure 2**

This start-up photo shows that the amplifier's V<sub>-</sub> pin (Trace B, midscreen) goes negative when the bootstrapping takes hold.

# Filter allows comparison of noisy signals

Mario Milberg, CNEA, Buenos Aires, Argentina

**W**HEN YOU NEED to compare the dc level of a noisy signal with a reference for further processing, the output of the comparator changes in a chaotic way when the dc level approaches that of the reference. You have a choice of two classic solutions to this problem: One is to add hysteresis to the comparator, but, if the noise level is high, the hysteresis must be correspondingly high. In this situation, you face a wide dead-band zone around the comparison trip point. The second solution is to add lowpass filtering to the noisy signal. This approach increases the response time, slowing down the system. This Design Idea proposes a third solution that avoids the cited drawbacks. In the circuit in **Figure 1**, the noise adds to the reference through a highpass filter, so the comparator's inputs see only the differ-

**Figure 1**

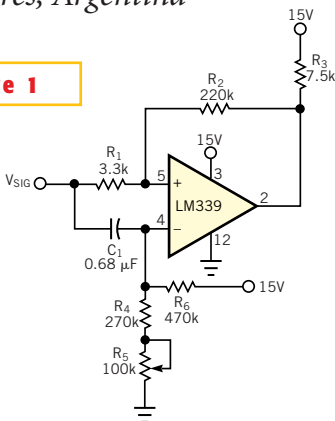

**By presenting the noise signal to both inputs of the comparator, this circuit can compare the dc levels of the signal and the reference.**

ence between the two dc levels:

$$V^+ = V_{DCSIG} + V_{NOISE} + V_{HYS}, V^- = V_{DCREF} + V_{NOISE}$$

$$+ V_{NOISE}, \text{ and } V^+ - V^- = V_{DCSIG} - V_{DCREF} +$$

$V_{HYS}$ , where  $V^+$  is the voltage on the comparator's positive input,  $V^-$  is the voltage on the negative input,  $V_{NOISE}$  is the noise riding on the signal, and  $V_{HYS}$  is the hysteresis accruing from the positive feedback to the positive input.

$C_1$ ,  $R_4$ ,  $R_5$ , and  $R_6$  form the highpass filter, whose cutoff frequency is  $f_c = 1/[2\pi C_1(R_4 + R_5) || R_6]$ . The cutoff frequency should be lower than the lowest frequency of the noise band.  $R_1$  and  $R_2$  establish the still-needed small amount of hysteresis.  $R_3$  is a pullup resistor for the open-collector output of the comparator. The comparator circuit worked successfully in a system that processes the fluctuating current generated by an ionization chamber in a neutron-flux measurement system.

**Is this the best Design Idea in this issue?** Select at [www.edn.com](http://www.edn.com).