

Edited by Bill Travis and Anne Watson Swager

## Simple circuit provides efficient PWM

Kenneth Levine, Eldec, Lynwood, WA

You often need to control the duty cycle of a square wave. The circuit in **Figure 1** works from a single 5V supply at a frequency of 100 kHz. With minor component changes, you can configure it for a range of frequencies. The circuit consists of a ramp (sawtooth) oscillator and a comparator. The circuit compares the ramp to an externally applied voltage,  $V_{\text{CNTRL}}$ . When  $V_{\text{CNTRL}}$  is greater than the ramp voltage, the PWM output is 5V. The sawtooth oscillator consists of a current source ( $R_1$ ,  $R_2$ ,  $R_3$ , and  $Q_1$ ), a timing capacitor ( $C_1$ ), and the oscillator-control circuitry ( $R_4$ ,  $R_5$ ,  $R_6$ , and  $IC_{1A}$ ). The oscillator-control circuitry sets the upper and lower voltages of the timing capacitor at 3 and 1V.

$R_1$  and  $R_2$  set the voltage at  $Q_1$ 's base to 1V.  $R_3$  and the  $V_{\text{BE}}$  drop (0.7V) are in parallel with  $R_1$ , so the voltage across  $R_3$  is 0.3V for a current of 200 mA. Because the emitter current greatly exceeds the base current, the collector current is nearly 200 mA. A capacitor receiving its charge from a current source charges linearly. The current in  $C_1$  is 200 mA, and the change in voltage is 2V (1 to 3V). From  $I=CdV/dt$ ,  $dt=10$  msec, and the frequency is 100 kHz. The oscillator-control circuitry uses a comparator with hysteresis to compare the capacitor (ramp) voltage

**Figure 1**

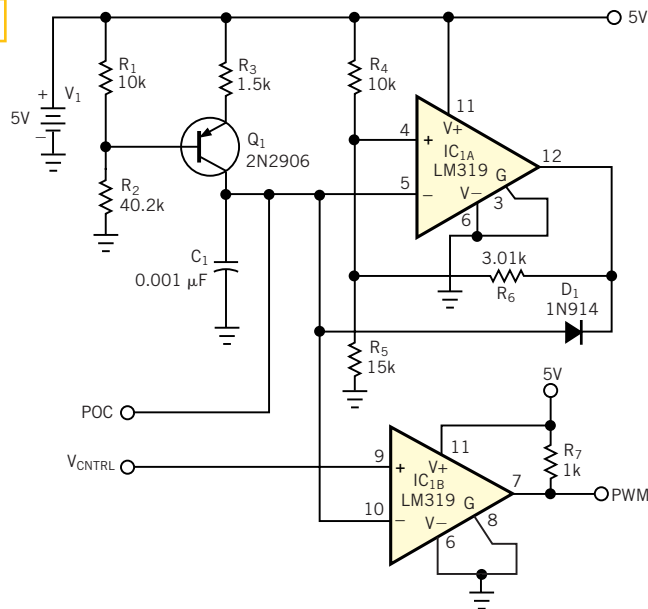

**A dual comparator and a handful of components configure an inexpensive PWM generator.**

with the charge limits. An externally applied power-on-clear (POC) signal ensures reliable start-up. POC must connect to an open-collector device that pulls to ground at power-on and produces no voltages when inactive.

After removal of POC,  $IC_{1A}$ 's Pin 5 is at ground,  $IC_{1A}$ 's Pin 12 is at open-collector status, and  $IC_{1A}$ 's Pin 4 is at 3V (the voltage across  $R_3$ ).  $C_1$  now starts charging. When the voltage on  $C_1$  exceeds 3V,  $IC_{1A}$ 's Pin 12 switches to nearly ground,  $IC_{1A}$ 's Pin 4 drops to 1V (the voltage across the parallel combination of  $R_5$  and  $R_6$ ), and the charge on  $C_1$  rapidly bleeds off through  $D_1$ . The discharge time is short enough to have a negligible effect on the oscillation frequency. When the voltage on  $C_1$  drops below 1V,  $IC_{1A}$ 's Pin 12 switches to open-collector status,  $D_1$

stops conducting, and  $C_1$  begins to charge again. The entire cycle repeats, creating sawtooth oscillation.

The circuit creates PWM by comparing the voltage on  $C_1$  with  $V_{\text{CNTRL}}$ . As long as  $V_{\text{CNTRL}}$  is greater than the voltage on  $C_1$ , the PWM output stays at 5V. You should limit  $V_{\text{CNTRL}}$  to a bit more than 1V and a bit less than 3V to prevent comparator oscillation. If the source of  $V_{\text{CNTRL}}$  can tolerate it, you can add hysteresis. The relationship of PWM to  $V_{\text{CNTRL}}$  is linear:  $\text{PWM width} = 50(V_{\text{CNTRL}} - 1) \%$ , valid for  $1V < V_{\text{CNTRL}} < 3V$ . To increase the operating frequency, you can replace the LM319 with a faster comparator. (DI #2309).

To Vote For This Design,  
Circle No. 385

- Simple circuit provides efficient PWM ..... 137
- Visual Basic models MDAC offset..... 138
- Charge-pump circuit divides by two ..... 140
- Pass transistor lowers dropout voltage.. 144
- PIC  $\mu\text{C}$  implements CRC-16 algorithm.. 146
- Monostable makes low-cost F/V converter..... 148

# Visual Basic models MDAC offset

Olga Belousava, Los Alamos, NM, and Alex Belousov, New York, NY

It's hard to imagine that, for such an old-hat item as a standard R-2R multiplying DAC (MDAC), there still exists some "dark area" in modeling and calculating its dc offset,  $V_{OFF}$ , and related output resistance,  $R_O$ . You can obtain some information from references 1 and 2 and other references regarding the code dependency of  $R_O$  and  $V_{OFF}$ , but the simplified formulas given therein are insufficient for thorough engineering analysis/design and computer modeling/simulation. Moreover, these formulas apply mainly to the case in which the Reference pin (Figure 1) is open, whereas most MDAC applications connect the Reference pin to a low-impedance source. Also, the source resistance,  $R_{IN}$ , has an impact on  $V_{OFF}$  and  $R_O$ . This Design Idea introduces an equivalent circuit for the MDAC and discusses mathematical models. A software program, "DAC Designer AO," simplifies the offset calculations. You can download the Visual Basic files from EDN's Web site, [www.ednmag.com](http://www.ednmag.com). At the registered-user area, go into the Software Center to download

**TABLE 1—MAXIMUM OFFSET WITH REF PIN GROUNDED**

N (bits)	Decimal	Hex	Binary (maximum)	$V_{OFF}$
8	235	00EB	11101011	$2.652 \cdot V_{OS}$
9	469	01D5	111010101	$2.763 \cdot V_{OS}$
10	939	03AB	1110101011	$2.875 \cdot V_{OS}$
11	1877	0755	11101010101	$2.986 \cdot V_{OS}$
12	3755	0EAB	111010101011	$3.097 \cdot V_{OS}$

the files from DI-SIG, #2305.

The models are based on the idealized R-2R resistive ladder in Figure 1 with zero on-resistance and infinite off-resistance in the switches and without current leakage or parasitic voltages. Figure 2 gives an equivalent reciprocal- $\pi$  network for the ladder, in which  $G_{11}$  is the input conductance with the output terminals shorted,  $G_{12}$  is the transfer conductance, and  $G_{22}$  is the output conductance with the input terminals shorted. The applicable math formulas are as follows:

$$G_{11} = 1/R,$$

$$G_{12} = \sum_{i=1}^N (D_i - 2^{-i})/R,$$

$$G_{22} = \left( \sum_{i=1}^N (D_i (1 + 2 \cdot 4^{-i})) - \sum_{i=2}^{N-1} (D_i (1 - 4^{-i})) \cdot \sum_{j=i+1}^N (D_j \cdot 2^{-j}) \right) / 3R.$$

It's obvious that  $G_{11}$  has a constant value, the reciprocal of the base resistance,  $R$ .  $G_{12}$  is a linear function of the input code and base resistance  $R$ . The expression for  $G_{22}$ , however, reveals complex, nonlinear behavior as a function of the digital input code. A Thevenin transform in Figure 2's circuit produces the simplified equivalent circuit in Figure 3. The output resistance,  $R_O$ , in the most common case, when the MDAC connects to

**Figure 1**

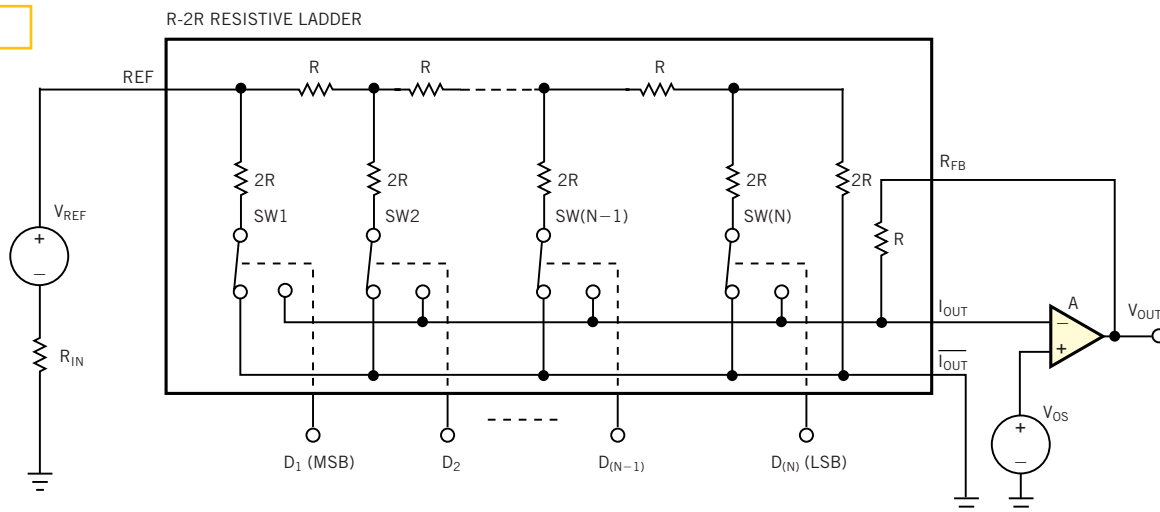

The output impedance of a multiplying R-2R DAC is a complex, nonlinear function (third equation in the text) of the digital input code.

a low-resistance source, is the reciprocal of  $G_{22}$ . The offset voltage is thus

$$V_{OFF} = V_{OS} \cdot (1 + R \cdot G_{22}).$$

**Table 1** gives the maximum theoretical values for  $V_{OFF}$  in 8- to 12-bit MDACs. You can easily obtain the exact values for  $V_{OFF}$  and  $R_O$  for any arbitrarily chosen input code by using the cited software program. The program also allows you to compute the statistics (maximum  $V_{OFF}$ , its mean, and standard deviation) for any predefined range of input codes. You can use the suggested equivalent circuit and mathematical models with any computer simulation packages in dc-analysis mode. (DI #2305).

**Figure 2**

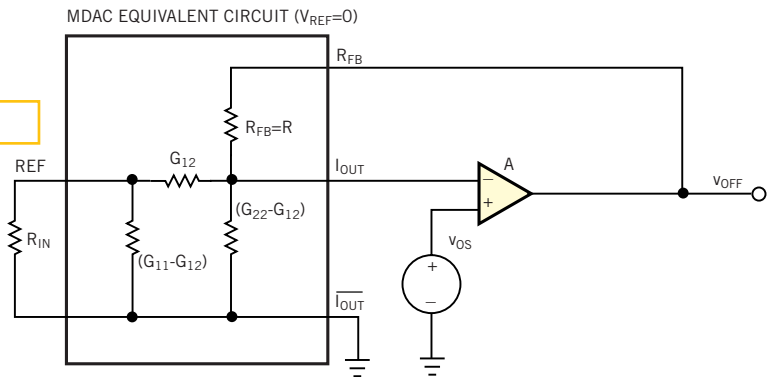

The input conductance, transconductance, and output conductance of the MDAC in Figure 1 provide a convenient simplification of the circuit.

**References**

1. Sheingold, Daniel H, Editor, *Analog-Digital Conversion Databook*, Prentice-Hall, 1986.
2. *Data Converter Reference Manual*, Volume 1, pg 2-540 to 2-541, Analog Devices, 1992.

**Figure 3**

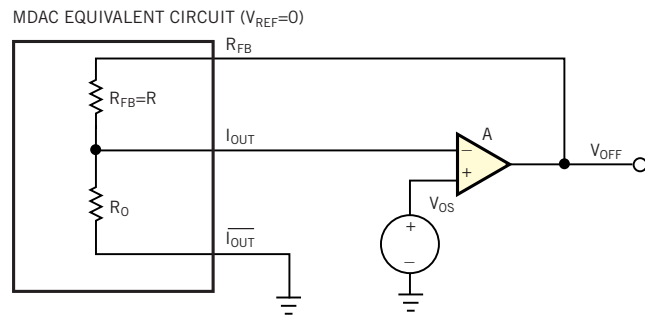

A Thevenin transformation of the equivalent circuit in Figure 2 produces a greatly simplified circuit.

To Vote For This Design,  
Circle No. 386

# Charge-pump circuit divides by two

*Budge Ing, Maxim Integrated Products, Sunnyvale, CA*

Small size and efficiency approaching 100% make switched-capacitor charge pumps popular for voltage doubling and inverting in miniature dc-dc applications. Few are aware, however, that most charge pumps can halve as well as double or invert an input voltage. The increasing adoption of low-voltage logic makes this ÷ 2 capability useful for generating low-voltage supplies in portable equipment. You can use it, for example, to convert a 3.6V RF-supply voltage to 1.8V for powering low-

**Figure 1**

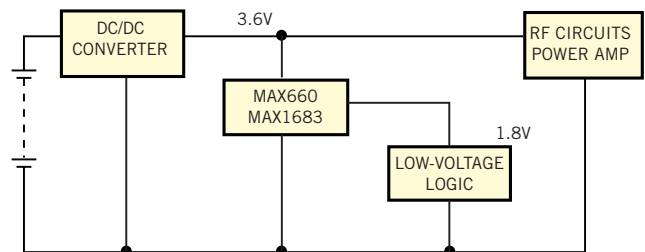

Simply reversing a voltage-doubler charge pump converts it to a voltage divider.

voltage logic (Figure 1). Simply reversing the input and output of a voltage doubler makes it a voltage divider.

**Figure 2**

Implementing this scheme with MAX660 or MAX1683 voltage-doubler charge pumps requires only three external capacitors (Figure 2). Both configurations in Figure 2 accept input voltages of 3.6 to 10V, but they present trade-offs in size and output-current capability.

For 3.6V inputs, the robust MAX660, which comes in an eight-pin DIP or SO package, delivers 150 mA with efficiency greater than 88% and an output-voltage drop of less than 300 mV. If you require a smaller package, the MAX1683 (avail-

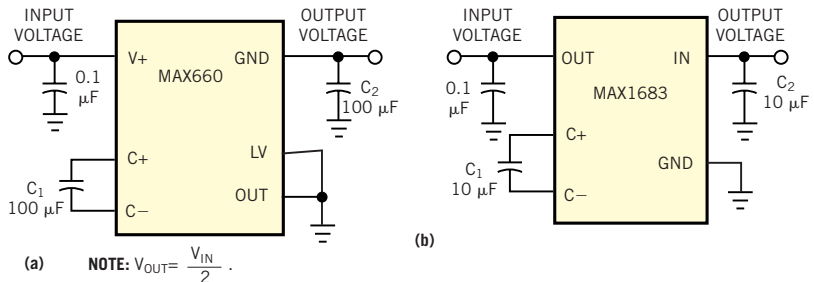

**A MAX660 voltage doubler makes an efficient 150-mA voltage divider (a); the smaller MAX1683 does the same for applications requiring only 50 mA (b).**

**Figure 3**

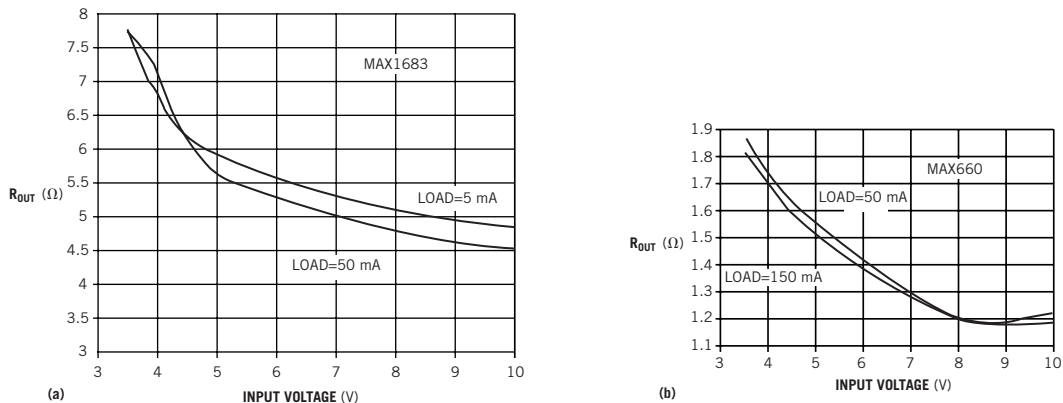

**Over the usable 3.6 to 10V input-voltage range, the small MAX1683 (a) exhibits higher output resistance than the more robust MAX660 (b).**

**Figure 4**

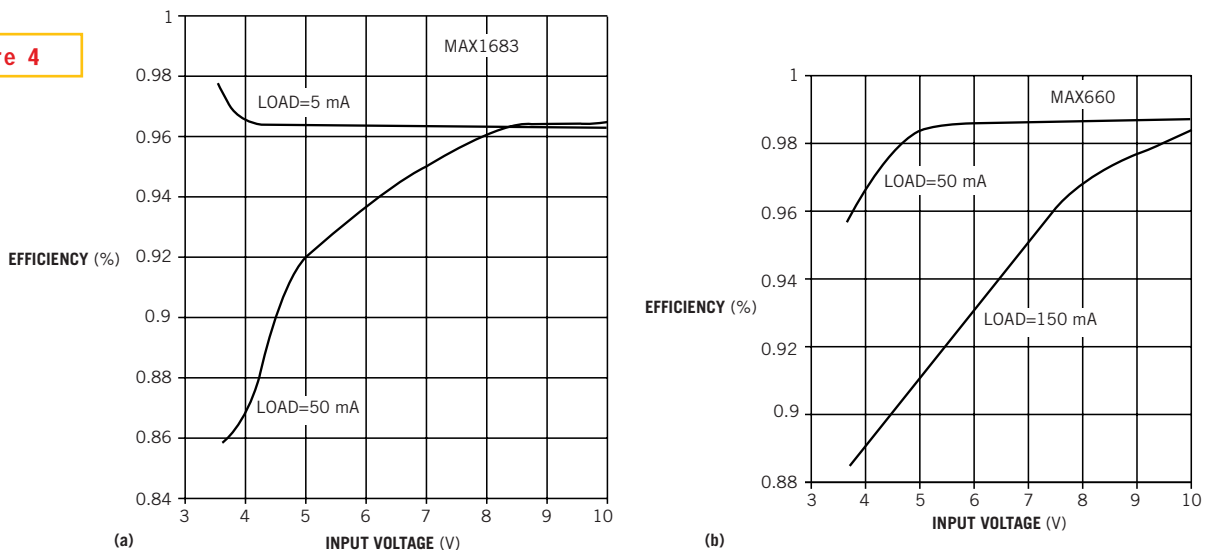

**Both the MAX1683 (a) and the MAX660 (b) offer better than 90% efficiency over a large portion of their usable operating range.**

able in a five-pin SOT-23) offers 50-mA capability with a 3.6V input and as much as 100 mA with inputs higher than 8V. Its efficiency is 97% at 5 mA and 86% at 50 mA. Each device has an internal clock. The MAX660 runs at a nominal 10 kHz (with the FC pin open), and the MAX1683 runs at a nominal 35 kHz. Each divider's output resistance depends on the internal clock frequency, the flying capacitor ( $C_1$ ), the resistance of the

$$R_{OUT} = \frac{1}{f_{OSC}C_1} + 4(R_4 + R_2 - R_1 - R_3) + 2R_{ESR},$$

internal switches, and the resistance of the output capacitor  $C_2$ . You can calculate the output resistance by: where  $f_{OSC}$  is the oscillator frequency,  $R_1$  to  $R_4$  are the  $R_{DS(ON)}$  values for the four internal switches, and  $R_{ESR}$  is the equivalent series resistance for the output capacitor,  $C_2$ . The graphs in **Figure 3** illustrate the

performance of the charge pumps operating in voltage-divider mode. **Figure 3a** shows the output resistance versus input voltage for the MAX1683. **Figure 3b** shows the same parameters for the MAX660. **Figure 4** shows efficiency versus input voltage for the MAX1683 (**Figure 4a**) and the MAX660 (**Figure 4b**). (DI #2301).

To Vote For This Design,  
Circle No. 387

## Pass transistor lowers dropout voltage

Matt Schindler, Maxim Integrated Products, Sunnyvale, CA

**W**ith linear regulators, you measure dropout voltage,  $V_{IN} - V_{OUT}$ , at the minimum input voltage for which the IC sustains regulation. Low dropout means longer battery life, because the load circuit continues to operate while the battery discharges to a lower terminal voltage. The external transistor helps to form a linear-regulator circuit whose dropout voltage at 100-mA load current is only 10 mV (**Figure 1**). (The linear-regulator IC by itself specs a 100-mV dropout at 100 mA.) The external transistor also boosts the maximum available load current to 1A.

Unorthodox connections enable the IC to drive  $Q_1$ . Connecting Pin 3 to the transistor's base allows base current to flow through the internal switching MOSFET, out of Pin 4, and through  $R_2$  to ground. The MOSFET then regulates  $V_{OUT}$  by controlling  $Q_1$ 's base current. Because  $C_2$  sets a dominant pole that stabilizes the loop, you should choose a ceramic type or other low-ESR capacitor.

$C_2$  improves the phase margin by forming a pole-zero combination that increases the phase at crossover.  $Q_1$  saturates when the battery voltage drops low enough for  $V_{OUT}$  to drop out of regulation, and  $R_2$  limits the base current for that condition to approximately 10 mA.  $Q_1$ 's collector-emitter voltage at saturation, 10 mV with 1-mA base current and 100-mA collector current, sets the dropout voltage for these conditions.

**Figure 1**

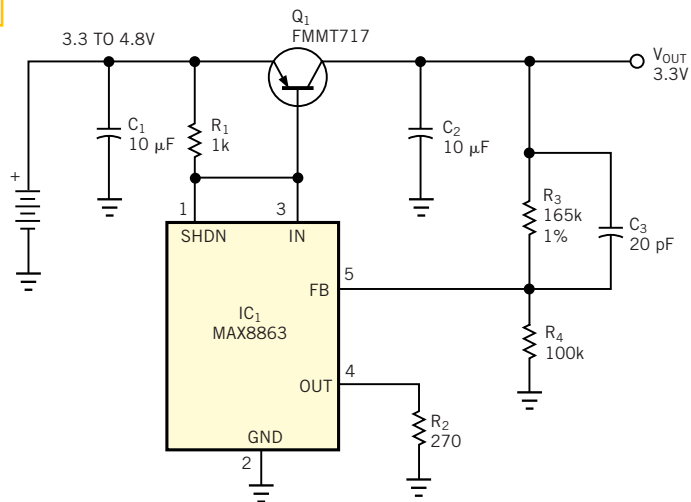

Unorthodox transistor connections to a low-dropout regulator allow you to squeeze a 100-mV dropout voltage down to 10 mV.

**Figure 2**

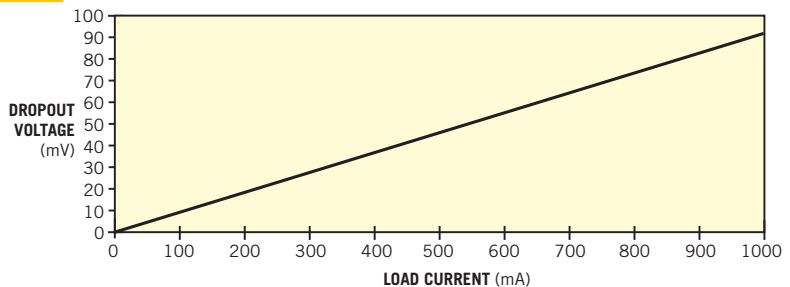

Dropout voltage for the circuit in **Figure 1** varies from 10 mV at 100 mA to 90 mV at 1A.

The measured dropout voltage varies with load current (**Figure 2**). The circuit delivers as much as 1A at 3.3V. You can adjust the output from 5.5V down to 1.25V using the formula  $V_{OUT} =$

$1.25[1+(R_3/R_4)]$ , with appropriate changes to the value of  $R_2$ , using the formula  $R_2 = (V_{IN(MIN)} - 0.7V)/10 \text{ mA}$ . Small components allow the entire circuit to occupy less than 0.24 in.<sup>2</sup> of board area.

(IC<sub>1</sub> comes in an SOT-23 package.) (DI #2323).

To Vote For This Design,  
Circle No. 388

## PIC $\mu$ C implements CRC-16 algorithm

Lon Glastner, Solutions Cubed, Chilo, CA

**D**etecting errors in serial data can be paramount in completing an embedded-control design. Determining which algorithm to use for detecting serial-communications errors depends on several factors. Ideally, the method should require minimal hardware and little computational power from your processor and still provide high-level protection against undetected data errors. The cyclic redundancy check (CRC) combines all these factors under one umbrella. A multitude of CRC flavors exists, including the Dow CRC (8 bits), CRC-16, and CRC-CCITT (both 16 bits). The CRC-16 uses a 16-bit shift register and can detect the following error types:

- any cluster of errors within a 16-bit section of data,
- any odd number of errors within the data field,
- all double-bit errors in the data field, and
- most large clusters of errors.

TABLE 1—XOR TRUTH TABLE		
X	Y	XOR
0	0	0
0	1	1
1	0	1
1	1	0

You can characterize the CRC-16 as both a polynomial expression and as a hardware-based shift register (**Figure 1**). You can implement a CRC-16 in a midrange PIC  $\mu$ C with minimal coding and without additional hardware. Selecting a  $\mu$ C with an on-chip USART, such as the PIC16C63, eases serial communications. This implementation does not focus on the mathematical proof of a CRC-16's error-correcting effectiveness. The CRC algorithm is so effective it's an industry-accepted method for detecting data errors. The heart of a CRC-16 algorithm is a shift register. You generate the shift register by shifting each data bit through the algorithm. In this imple-

mentation, the data shifts the most significant bit first, one data byte at a time.

Two temporary registers buffer the data to prevent the shifting from corrupting the data. The shift register comprises two separate 8-bit registers, CRC16\_HI and CRC16\_LO. The most significant bit of CRC16\_HI is the location of Stage 16 (**Figure 1**). From the **figure** and **Table 1**, you can see that the result of XORing the input data bit and the contents of Stage 16 of the shift register determines the effect that new data has on the shift register. If the result is a one, then you must complement the contents of stages 2 and 15 before rotating the new data into the shift register. If the result is a zero, then the new data can rotate immediately into the shift register. Some housekeeping tips can be helpful here. The data transmitter should generate its CRC-16 in the same manner as the data receiver. Also, it's advisable to clean the CRC-16 shift register before rotating the first data bit of the data string into it.

**Figure 1**

(a) POLYNOMIAL REPRESENTATION OF CRC-16:  $X^{16}+X^{15}+X^2+1$   
(b) HARDWARE REPRESENTATION OF CRC-16

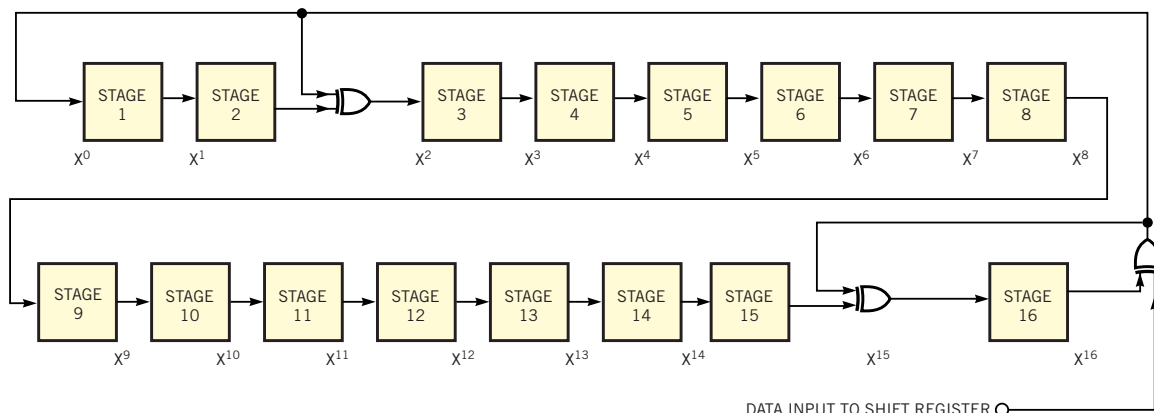

You can represent the CRC-16 algorithm as both a polynomial (a) and a hardware-based shift register (b).

How does the CRC-16 identify data errors? The simplest method is to attach the shift register to the end of the data string. In this implementation, the CRC16\_HI register should follow the last byte of data sent. The CRC16\_LO register follows the CRC16\_HI register. If the receiving system computes a CRC-16 value from all the data bytes and the attached shift register (CRC16\_HI and CRC16\_LO), then the resulting CRC-16 code is 0000h. Any nonzero result indicates an error in the data. In some systems, an error may occur that results in all zeros being sent as the data and attached CRC-16. This type of error poses as error-free data. In these systems, you can overcome the false indication by complementing the CRC-16 before attaching it to the data string. The CRC-16 shift register generated by attaching the complement is always 800Dh.

The code fragment in **Listing 1** generates a CRC-16 shift register on a byte-by-byte basis. You could embed this code within serial-recv and serial-send routines to provide a powerful error-detection tool. You can easily generate the

**LISTING 1—PIC CODING FOR CRC-16 SHIFT REGISTER**

```

;*****
;MAKE_CRC16 - This routine generates a CRC-16 shift register from the data byte stored
;in the DATA_REG register. DATA_TEMP0 and DATA_TEMP1 are used to buffer the data
;and prevent it from being corrupted by the CRC-16 generation process.
;*****
MAKE_CRC16
    movf    DATA_REG,W           ;Store data in temporary register
    movwf   DATA_TEMP0         ;Set counter for 8 data bits
    movlw   '00001000'b         ;Load counter register
    movwf   NUMBER_BITS

More_Rotates
    movf    DATA_TEMP0,W       ;Move buffered data to 2nd buffer
    movwf   DATA_TEMP1         ;This register is corrupted with every pass
    movf    CRC16_HI,W          ;Move upper shift register to working reg.
    xorwf   DATA_TEMP1         ;XOR shift register with data register
    btfss   DATA_TEMP1,7       ;MSB is XOR of stage16 and input data bit
    goto    No_Xorwf            ;If bit is clear then no complement of stage2,15
    movlw   '00000010'b         ;Prepare to complement stage2
    xorwf   CRC16_LO            ;Complement stage2 of shift register
    movlw   '01000000'b         ;Prepare to complement stage15
    xorwf   CRC16_HI            ;Complement stage15 of shift register

No_Xorwf
    rlf     DATA_TEMP0         ;Rotate next data bit into position
    rlf     DATA_TEMP1         ;Rotate XOR of input into CRC16_LO
    rlf     CRC16_LO             ;Shift CRC16 register
    rlf     CRC16_HI             ;Shift CRC16 register
    decfsz  NUMBER_BITS         ;Count out 8 data bits
    goto    More_Rotates        ;Not finished with this data byte
    return                       ;This byte is finished
    
```

CRC-16 on the fly, thus minimizing the use of processor resources. You can download the listing from EDN's Web site, [www.ednmag.com](http://www.ednmag.com). At the registered-user area, go into the Software Center to

download the files from DI-SIG, #2321. (DI #2321).

To Vote For This Design,  
Circle No. 389

# Monostable makes low-cost F/V converter

Mark Brinegar, Dart Controls Inc, Zionsville, IN

The circuit in **Figure 1** is a low-cost frequency-to-voltage (F/V) converter. Using a monostable (one-shot) multivibrator, the circuit accepts an open-collector square wave that varies in frequency from 0 to 10 kHz. The one-shot produces a pulse of a fixed width each time the input signal triggers it. The result is a variable-frequency, variable-duty-cycle signal at the output of the one-shot. The time constant determined by  $R_2C_1$ , 100  $\mu$ sec, determines the width of the pulses the one-shot produces. This time matches the period of the maximum input frequency (10 kHz). The duty cycle of the one-shot's output is thus 100% when the input is at its maximum frequency.

The variable-frequency, variable-duty-cycle output of the one-shot is the input for the lowpass filter comprising  $R_3$  and  $C_3$ . The net result is, as the input fre-

quency varies from 0 to 10 kHz, the dc output signal varies from 0V to  $V_{CC}$ . You can alter the circuit to accommodate different input frequencies by simply adjusting the  $R_2C_1$  time constant to match

the period of the desired maximum input frequency. (DI #2322).

To Vote For This Design,  
Circle No. 390

**Figure 1**

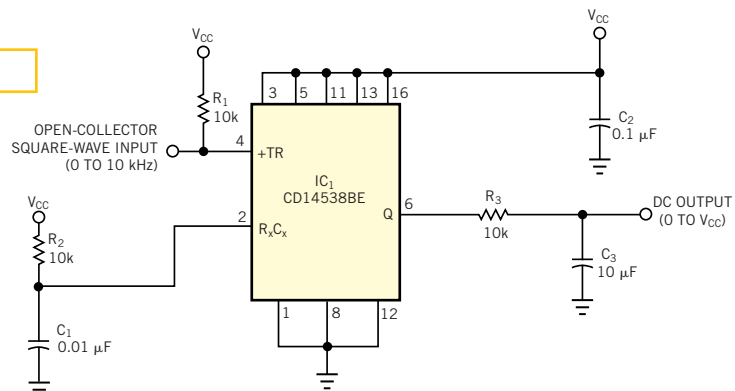

**A single CMOS one-shot multivibrator provides a simple and inexpensive frequency-to-voltage conversion function.**

## Design Idea Entry Blank

Entry blank must accompany all entries. \$100 cash award for all published Design Ideas. An additional \$100 cash award for the winning design of each issue, determined by vote of readers. Additional \$1500 cash award for annual Grand Prize Design, selected among biweekly winners by vote of editors.

To: Design Ideas Editor, EDN Magazine  
275 Washington St, Newton, MA 02158

I hereby submit my Design Ideas entry.

Name \_\_\_\_\_

Title \_\_\_\_\_

Phone \_\_\_\_\_

E-mail \_\_\_\_\_ Fax \_\_\_\_\_

Company \_\_\_\_\_

Address \_\_\_\_\_

Country \_\_\_\_\_ ZIP \_\_\_\_\_

Design Idea Title \_\_\_\_\_

Social Security Number \_\_\_\_\_  
(US authors only)

**Entry blank must accompany all entries.** (A separate entry blank for each author must accompany every entry.) Design entered must be submitted exclusively to *EDN*, must not be patented, and must have no patent pending. Design must be original with author(s), must not have been previously published (limited-distribution house organs excepted), and must have been constructed and tested. Fully annotate all circuit diagrams. Please submit software listings and all other computer-readable documentation on a IBM PC disk in plain ASCII.

Exclusive publishing rights remain with Cahners Business Information unless entry is returned to author or editor gives written permission for publication elsewhere.

In submitting my entry, I agree to abide by the rules of the Design Ideas Program.

Signed \_\_\_\_\_

Date \_\_\_\_\_

**Your vote determines this issue's winner. Vote now, by circling the appropriate number on the reader inquiry card.**