

CREATIVE POSSIBILITIES EXIST IN DERIVING AUXILIARY RAILS FROM DC/DC CONVERTERS. SLAVE CONVERTERS, WHICH ARE BASED ON “TRANSFER-FUNCTION COINCIDENCES,” OFFER TREMENDOUS POTENTIAL.

Slave converters power auxiliary outputs

THE AGE OF CREATIVE THINKING in dc/dc converters is not over. So-called “new” topologies may appear periodically, but if they are not resonant types, almost invariably they are just variations of the three primary topologies: buck, buck-boost, and boost. Fundamentally new topologies may well appear in the not-so-distant future, but even now you can create wonderful composite topologies from the primary topologies. The end game may vary. It could be either to eke out better performance from a single output converter or to generate auxiliary rails.

A promising and cost-effective route for deriving auxiliary outputs is the concept of slave converters. This discussion deliberately takes a detour from the rather well-trodden path of placing several windings on a core to produce so-called regulated auxiliary outputs. This type of design may form the subject of some very clever patents, but the truth is that no one really likes anything other than easily available off-the-shelf inductors. So unless absolutely unavoidable, most engineers would prefer to use even several single-winding inductors rather than a tapped inductor, custom transformer, or a complex coupled inductor.

Slave converters are symbiotic converters that run off the control waveform of a conventional PWM-controlled “master” converter and thereby share the same duty cycle and phase. The slave converter has no independent control circuit or a feedback node. It may use an active switch, but it may also just have coupling through a dc blocking capacitor to the master. Power-supply designers will immediately realize that it sounds like a pipe dream to expect any sort of regulation from the slave stage. This lack of regulation is true in most cases, but reassuringly and perhaps unexpectedly, not always. In some cases, some form of slave regulation automatically follows due to “transfer-function coincidences.” The resultant auxiliary output can be useful for certain appli-

cations. And the good news is that these outputs will be very cheap, if not free of charge.

STAND-ALONE CONFIGURATIONS

Before combining the topologies, you should realize that there are simple things you can do individually with each of the three main topologies that are easy to overlook. The three topologies of buck, buck-boost, and boost form the essential building blocks of all square-wave switching converters, barring possibly some very obscure, exotic, or unproducible ones. In fact, even the Cuk, sepic (single-ended primary inductance converter), and the lesser-known zeta converters are actually just cleverly disguised versions of a boost/buck-boost stage followed by a buck stage. And the forward converter, with all its variations, and the ubiquitous flyback converter are just transformer-isolated versions of the buck and buck-boost topologies, respectively. You can also consider outputs that derive from multiple-windings on a magnetic element as several converters, usually of the same topology and same duty cycle, working in tandem. Thus, a bias/auxiliary winding in opposite phase to the main winding of a forward converter is just a low-power flyback slave converter working in parallel with the master forward converter. Thus, the three basic topologies are undisputed kings—the “big three” of power conversion. Any creative thinking must realistically take this fact into account.

There are different configurations of the standard topologies. The schematic of these configurations may look different, but these differences do not amount to a fundamental or topological change. Nowadays, it is customary to call the lower rail the system ground—a “negative ground” convention. But for many years, it was commonplace to refer to the upper rail as the ground—“positive ground” in this case. Although there are some practical EMI-versus-thermal-management trade-off issues also

related to the typical switch/diode structures, it's almost traditional that many telecomm systems are still positive ground. Now, it seems that it should have been just a matter of convention which rail to label "ground." But consider this fact: A dc/dc converter has two input rails and two output rails, one of which is shared. If you require the "ground" to serve as the common rail, the circuit schematic needs to change, and not just cosmetically. Engineers have quickly learned to draw the ground-negative circuit from a ground-positive circuit, and vice versa, by the simple trick of inverting all circuit polarities. So, for example, the anode (positive terminal) and cath-

ode (negative terminal) of a diode are interchanged, which is equivalent to reversing the direction of the diode.

When you combine topologies, you may connect the different stages together in rather strange ways, and it may not be completely obvious what configuration you're dealing with. You have to look at the orientation of the diode to determine the configuration. For example, the switching node between diode and inductor connects to the cathode of the diode in a positive-buck configuration, whereas the switching node connects to the anode for the negative-buck configuration.

In all cases, the details of the switch are

not directly related to the configurations. In general, the switch can be either a pnp or an npn bipolar transistor or sometimes either an N-channel or P-channel MOSFET. There are certain practical considerations for the switch, such as the drive, its ground referencing, and the fact that current can flow in the reverse path through the intrinsic diode of a MOSFET, but nothing to do with the fundamentals of the topology or its configuration.

Note that the words "boost," "buck," or "buck-boost" always refer only to the magnitudes of the input and output voltages. Thus, you need qualifiers like "negative-to-negative" and "negative-to-pos-

Figure 1

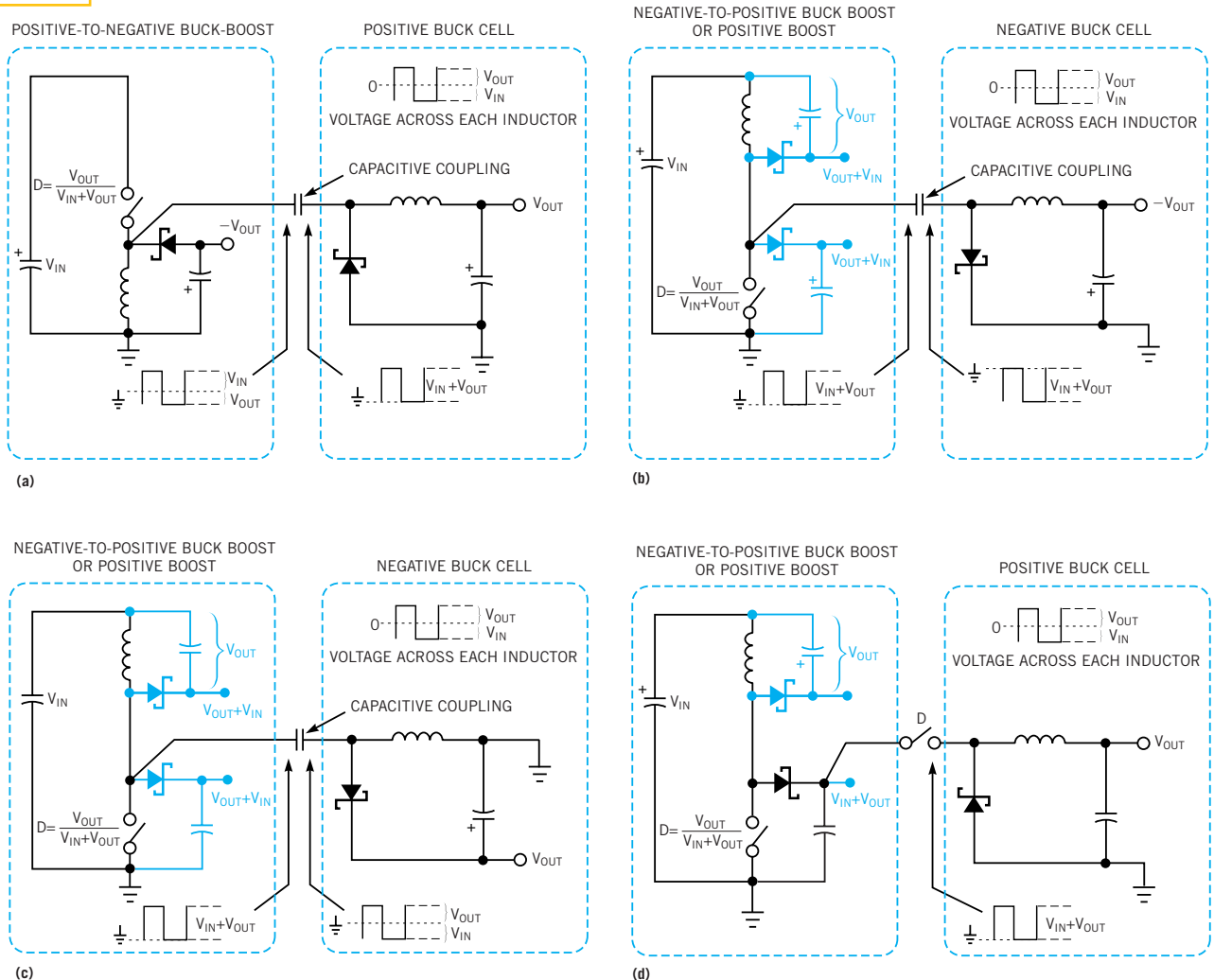

Examples of combined dc/dc converter topologies are the zeta (a), Cuk (b), sepic (c), and boost-buck cascade (d).

itive” to fully describe the actual configurations. The negative, or inverted, form of the modern boost converter (**Figure 1b**) is in full form a “negative-to-negative” boost converter. For example, this converter type would convert -12V to -48V relative to the common, or ground, rail.

THE ZETA CONVERTER

Little information is available on the zeta topology, but it is a useful entry point for understanding the principle of combinations and transfer-function coincidences. Consider a switch that provides two output rails, $\pm 12\text{V}$, for example (**Figure 1a**). The input is 5V . The first stage is simply a regulated positive-to-negative buck-boost stage that converts 5V to -12V . The switching waveform of this stage has a peak-to-peak swing of $12+5=17\text{V}$. This voltage swing is the ac-coupled input to the second stage. The capacitor preserves the swing’s shape, but the diode clamps the waveform to a different level. When you ac-couple, or dc-block, any signal through a capacitor, only level shifting takes place, no shape change occurs.

The slave stage is basically just a passive buck stage without the switch, hereafter called a “buck cell.” This buck cell is a significant and pervasive switchless slave stage because you can easily inject a swinging-voltage waveform between the diode and inductor. In this implementation, the buck cell thinks that its input comes from a boost stage, not by a buck-boost, because the applied peak-to-peak switching voltage is 17V . This voltage swing is the same as if you take a conventional buck converter (with an active switch) and apply 17V dc at its input. The duty cycles of the master and slave are identical. For a buck-boost, the duty-cycle equation is $D=V_{\text{OUT}}/(V_{\text{IN}}+V_{\text{OUT}})$, ignoring switch and diode forward drops. This duty cycle is $12/(12+5)=70\%$ for either stage. The buck stage with an effective input voltage of 17V running at a duty cycle of $D=0.7$ will therefore have an output voltage equal to $D \times V_{\text{IN}}=17 \times 0.7=12\text{V}$. This voltage turns out to be the same as for the other stage, though with an opposite polarity.

You can repeat this calculation for any valid input voltage, and you will find that

the magnitudes of the outputs of both stages are always the same. This is an example of a transfer-function coincidence. The slave stage “automatically” regulates to 12V , just by regulating the master to -12V . This automatic regulation results from the interaction of the individual stages’ respective transfer functions. The general equations are

$$D = \frac{V_{\text{OUT(BUCKBOOST)}}}{V_{\text{OUT(BUCKBOOST)}} + V_{\text{IN}}} \quad (\text{BUCK - BOOST})$$

and

$$V_{\text{OUT(BUCK)}} = D \times V_{\text{IN}} \quad (\text{BUCK}).$$

So, for the buck cell, if you let $V_{\text{IN}}=V_{\text{OUT(BUCKBOOST)}}+V_{\text{IN}}$ (V_{IN} is the effective input dc voltage to the buck), then

$$V_{\text{OUT(BUCK)}} = \frac{V_{\text{OUT(BUCKBOOST)}}}{V_{\text{OUT(BUCKBOOST)}} + V_{\text{IN}}} \times (V_{\text{OUT(BUCKBOOST)}} + V_{\text{IN}})$$

The result is

$$V_{\text{OUT(BUCK)}} = V_{\text{OUT(BUCKBOOST)}}$$

This equality applies to the zeta converter, as well as the Cuk and sepic converters. The latter two topologies involve

variations of the configurations of the same building blocks in a zeta converter. However, the building blocks are disguised because they essentially “gray-out” (or in this case “blue out”) the intermediate rail (**Figures 1b** and **1c**).

Figure 1 does not include the details of the switch—its drive, local ground, or feedback. These details are irrelevant to this discussion of power flow and topology.

Because the effective input to the buck cell is 17V , you can use a conventional 5-to- 17V boost converter in front of the buck cell. Then, you can rectify this 17V output and actively switch it before injecting it into the buck cell. If the duty cycle of this switch is the same as that of the preceding boost stage, the buck stage simply down-converts from 17V to 12V (**Figure 1d**). As far as the buck stage’s inductor is concerned, there is no difference in the voltages across it in going from **Figure 1a** to **1d**. **Figure 1d** is a cascaded, two-switch, boost-buck master-slave, derived from the zeta configuration.

Looking at the nuts and bolts of this boost-buck cascaded configuration, you have several ways to implement the master-slave combination:

1. You can PWM-control the first stage

Figure 2

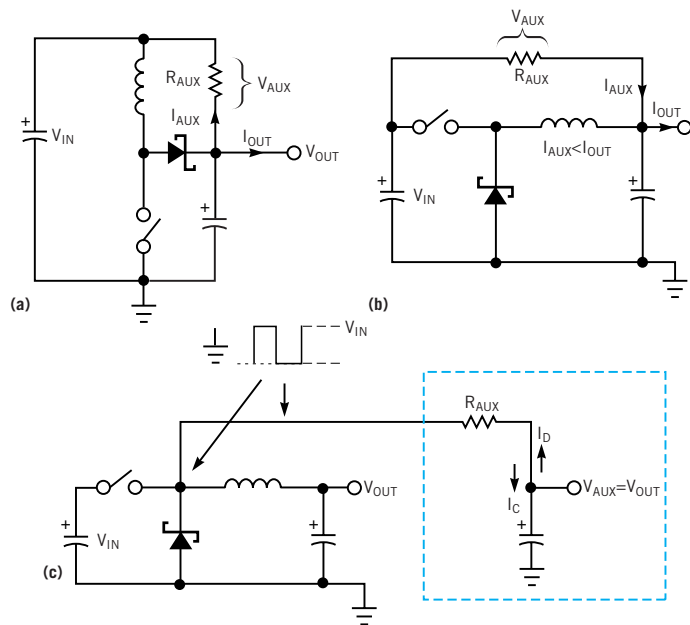

Strapping a resistor between the input and output rails of a stand-alone boost converter provides a reasonable amount of auxiliary power (a). In the buck version, you have to ensure that the output capacitor doesn’t charge up through the auxiliary resistor (b). The “inductorless” buck cell generates very low-power auxiliary rails (c).

(master) to regulate its output voltage, V_{MID} , to 17V, and then pass on the duty cycle of the first stage to the second stage. V_{OUT} will automatically equal 12V as the output from the second stage. However, if the input increases to 10V, for example, you need to regulate V_{MID} to $12+10=22V$ to keep V_{OUT} at 12V, which may be practically hard to implement from a control viewpoint. If V_{MID} is fixed at 17V, V_{OUT} drops to $V_{MID} - V_{IN} = 7V$.

2. You can PWM-control the first stage (master) to regulate the output of the second stage to 12V, while passing on the duty cycle of the first stage to the second stage. If the input is 5V, V_{MID} will automatically equal 17V as the output of the first stage. V_{MID} will automatically change to 22V if the input increases to 10V.

3. You can also PWM-control the second stage (master) to regulate the output of the first stage to 17V, while passing on the duty cycle of the second stage to the first stage. The output from the second stage would automatically equal 12V. Again, due to the need to change V_{MID} as the input changes, this approach may be hard to implement.

4. You can also PWM-control the second stage (master) to regulate V_{OUT} to 12V, while passing on the duty cycle of the second stage to the first stage. V_{MID} would automatically equal 17V. And if the input increases to 10V, V_{MID} will automatically change to 22V.

A pattern is emerging. Whichever stage you designate the master or the slave and however you implement feedback, the applicable relationship for this cascaded boost-buck stage is $V_{MID} = V_{OUT} + V_{IN}$. Note that V_{MID} is the intermediate voltage level and is the output of the boost stage and the input to the buck stage.

Rewriting this equation as $V_{MID} - V_{IN} = V_{OUT}$, you can see that this approach automatically regulates the difference between the output and input voltages of the boost stage to the same value as the output of the buck stage. This result gives rise to another concept—"strapped" auxiliary outputs.

STRAP THE AUXILIARY OUTPUTS

You may not have realized it, but you can always strap a resistor between the input and output rails of a stand-alone boost converter and draw a reasonable amount of auxiliary power through it

Figure 3

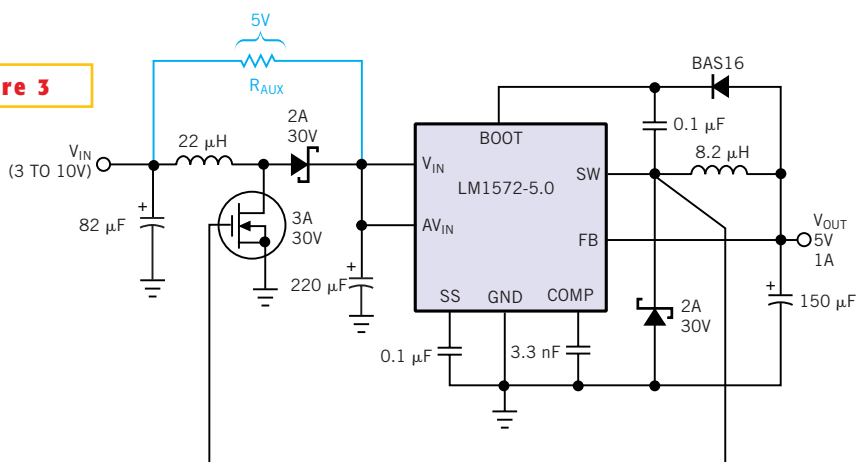

A slave boost preregulator to a master buck topology turns the circuit into a step-up or step-down converter.

(Figure 2a). However, because you normally regulate the main boost output to a set value, the difference between the output and input will vary as the input changes. So, the voltage across this auxiliary load resistor will be unregulated. Further, this secondary voltage source does not reference the system ground in a very usable way, although you could still use it to provide energy to a stand-alone circuit, such as an LED display. For example, you could use the secondary source to provide a simple visual indication that the boost converter is actually switching, which is hard to implement just by using the output rail.

However, for the case of the boost-buck cascade previously discussed, the strapped boost auxiliary source is in fact regulated to the same level as the output of the slave buck under steady-state conditions. Regulation is always nice to have for all the usual reasons, such as higher efficiency and elimination of series-pass elements.

Another example of strapped voltage sources makes the same attempt for a buck converter (Figure 2b). An obvious limitation here is that the output capacitor will quickly charge up through the auxiliary resistor. However, closer examination shows that if $I_{AUX} < I_{OUT}$, there is no net dc charging current into the capacitor, and this approach works. Generally speaking, whether combining topologies or just generating auxiliary sources, you should always watch out for inadvertent current paths that could alter the basic dc operating condition and

even render the main stage unusable.

CONSIDER BOOST-BUCK COMPOSITES

Possibly the most frequently discussed composite topology is a series combination of a boost and a buck. This combination has always been of interest because it provides a step-up or step-down (buck-boost) response leading to a flexible peg to fit almost any hole. But there are many ways of actually combining the boost and the buck: cascaded (series), interleaved, and parallel combinations. Within each of these categories, subcategories arise by the way you drive the switches. In fact, understanding the drive mechanism is almost as important as the combinations themselves.

An elementary implementation of a cascaded boost-buck applies PWM control to one switch with the other fully on or off, as applicable. This implementation requires PWM control of the boost switch, with the buck switch turning fully on when step-up operation is necessary. And when a step-down operation is necessary, the buck switch has PWM control with the boost switch fully off. Strictly speaking, this approach is not a composite, because only one topology works at any given time. It is more like flipping channels or topology-on-demand. But you could also have a case in which both the switches have independent PWM control and in which they run in-phase or out of phase. However, these more complex dual-control types are beyond the scope of this discussion.

The focus here is on cost-effective,

two-stage combinations of the basic three configurations for which the drive for both stages has the same duty cycle. This approach calls for only one PWM controller, the master, and another other serving as a slave, although the designations are virtually interchangeable. Within this category of interest, there are also versions that use just one active switching element. This version was once rather grandiosely called the “topological reduction of a switch” during the development of the Cuk converter. In fact, the same single-switch/dual-topology situation exists for the zeta, the sepic, and the Cuk converters. All three topologies essentially comprise a buck-boost stage followed by a buck cell, although the buck cell always “thinks” that it is preceded by a boost stage. What differs among these seemingly different topologies is the configurations of the individual topologies and the mutual referencing between the two stages. In fact, both the sepic and the Cuk use a negative-to-positive buck-boost

Figure 4

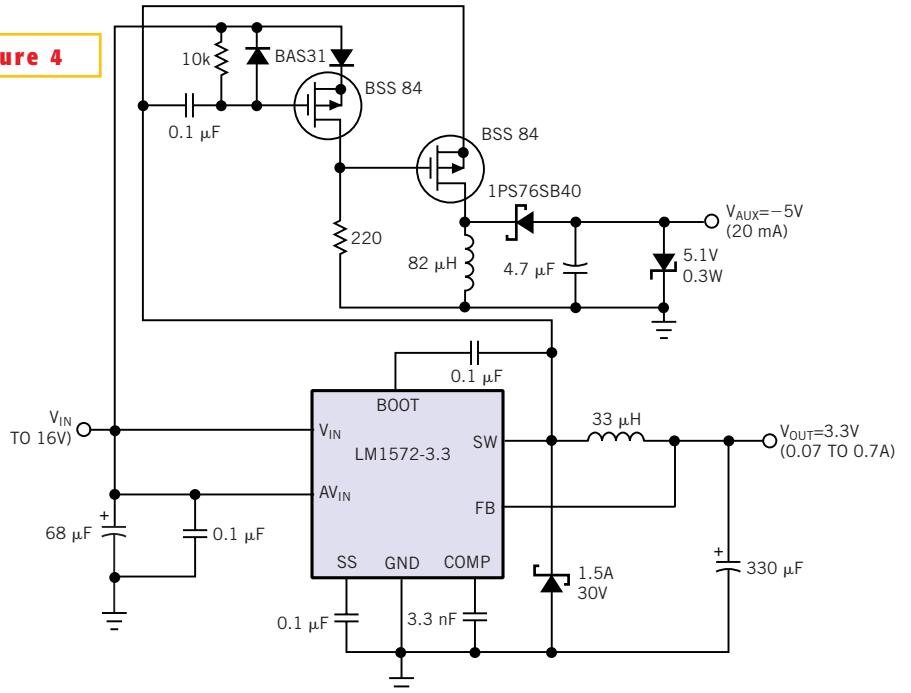

Operating a slave buck-boost converter in discontinuous-conduction mode (DCM) and a master buck converter in continuous-conduction mode (CCM) cancels V_{out} 's dependency on V_{in} .

stage and a negative buck cell. The difference between the sepic and Cuk is that the referencing of the buck cell to the first stage (ground) is reversed (**Figures 1b** and **1c**). Also, notice the “hidden rails” (the shaded portions on the **figures**) that exist within these topologies. You can reincarnate these rails to get additional auxiliary voltage sources. You can also combine the sepic and the Cuk by coupling their respective buck cells to the same switching-node point of a single buck-boost stage, which requires separate coupling capacitors. The result is a V_{OUT} and $-V_{OUT}$ output pair, like the zeta.

HISTORY EXPLAINS RIPPLE STEERING

The voltages across either inductor of all topologies in **Figure 1** are the same, leading to a concept called “ripple steering,” which is easiest to explain from a historical perspective.

The Cuk converter was more of a discovery rather than a deliberate invention. (In fact, this author, too, while trying to exploit the RCD clamp of a flyback stage

to generate a negative voltage rail for some control purpose, ran across the Cuk scheme.) In the usual schematic of an RCD clamp, the anode of the diode connects to the collector/drain of the switch, followed by a capacitor that connects to ground (ignoring R temporarily). However, it doesn’t make any difference to the performance of the clamp if you reverse the relative positions of the capacitor and diode.

So, suppose you connect the capacitor to the switch and the diode with its cathode to ground. In this case, the anode of the diode goes momentarily negative (below system ground) whenever the switch of the flyback stage turns on. You can simply use another diode to peak-charge a small capacitor to collect this negative transient and create a low-power negative rail. You can also succumb to the natural temptation of a switching-power-supply designer to smooth out the negative transient by placing an inductor at the anode of the diode followed by a capacitor. This approach turns the simple flyback+RCD into a Cuk converter

(**Figure 1b**). The Cuk converter in principle draws all the primary power from this new negative rail. The C of the RCD clamp has become the coupling capacitor of the Cuk, and the D of the clamp has become the diode of the passive buck cell.

But Cuk went much further (**Reference 1**). He and his group noticed that the voltages across the two inductors was the same. So why not save money and wind them together on a single core? When they did, they saw that the current ripple on one or the other winding was dramatically less than before. And so was born the concept of ripple steering. There is no reason why you can’t apply this concept to all the other composites in **Figure 1**. Remember that the approaches discussed here shy away from coupled inductors. But a point worth making for the two-inductor approach is as follows: from a magnetics point of view, an inductor belonging to a given stage (buck-boost or buck) does not know if it is working in a Cuk, sepic, zeta, or the cascaded, master-slave, two-switch boost-

buck composite. Also, the applied volt-seconds is the same for either stage and for all these topologies. The average current in the boost-buck inductor need not be the same as for the buck cell. But, that too, is the same for any of the topologies in **Figure 1**. These statements assume the same input-output voltages and the same effective or lumped output power.

Because the similarities between the composite topologies in **Figure 1** are so striking, you should not be surprised to learn that their transfer functions are identical: $V_{OUT}/V_{IN}=D/(1-D)$. This transfer function is the same as that of the primary (single-inductor) buck-boost.

This raises a key question: How similar are the boost-buck composites to the primary buck-boost? Input-to-output polarity reversal can occur, but what else? To answer this question, consider the shape of the current waveform of the input and output capacitors. In a buck, the input current is pulsating, but the output current is relatively smooth as it comes through an inductor. For a boost, the input current is smooth as it is in series with the inductor, but the output current pulsates. In a buck-boost, both the input and output capacitor currents are pulsating. So, a boost-buck essentially combines the best of the smooth boost input and the smooth buck output at the cost of an extra inductor and possibly an extra switch. Therefore, despite mimicking known transfer functions, the composites behave very differently. They can in general provide certain advantages in performance over the primary topologies, but they still do not become fundamentally new topologies.

Another example of an advantage in performance is based on the operation of a buck switcher IC (**Figure 3**). The input range of the LM1572 is 8.5V to 16V and its output in this example is 5V. However, once the IC achieves startup, you can make it work down to a few volts at the input while maintaining the output at 5V. This feature turns the IC into a step-up or step-down converter. Boost pre-regulators are not new, but in this case, no independent PWM control is necessary for the pre-regulator. The circuit is essentially a two-switch, master-slave, boost-buck cascade, with the buck stage being the master. Also, related to the discussion of strapped rails, a free regulat-

ed voltage source is also available across the auxiliary load resistor R_{AUX} once the circuit achieves steady state.

THE “INDUCTORLESS” BUCK CELL

The advantages of the LCD—in this case standing for inductor-capacitor-diode—buck cell have become apparent. An attractive method for generating very low-power auxiliary rails is the inductorless or “RC” buck cell. The approach in **Figure 2c** essentially piggybacks an RC network on top of a conventional buck. If you assume that the RC time constant is “large,” V_{AUX} is fixed during steady-state operation. Then the charging and discharging currents going through the capacitor have the following relationships, assuming no load current:

$$I_C=(V_{IN}-V_{AUX})/R$$

and

$$I_D=(V_{AUX})/R.$$

Just as for an inductor working in steady state, the term $\Sigma v\Delta t$ over a complete cycle must be zero (no net voltseconds increase). Likewise, for a capacitor, $\Sigma i\Delta t$ must be zero (no net increase in charge).

Thus, because the charge time is D/f and the discharge time is $(1-D)/f$, where D is the duty cycle and f is the switching frequency,

$$I_C \times D = I_D \times (1-D)$$

or,

$$(V_{IN}-V_{AUX}) \times D = (V_{AUX}) \times (1-D)$$

and

$$V_{AUX} = D \times V_{IN}.$$

This result is essentially the same as the buck converter equation of

$$V_{OUT} = D \times V_{IN}.$$

Thus,

$$V_{AUX} = V_{OUT}.$$

You can now see that the output of an inductorless buck cell with no load has the same output voltage as a conventional buck converter operating in continuous mode.

In fact, you can use the switching node of any topology to drive the RC cell and then similarly calculate its output voltage based on the actual applied duty cycle. The problem is that the moment you

draw external power from this inductorless buck cell, you disturb the charging and discharging currents, which leads to a droop in its output. You could try to reduce this output error by making the load current a smaller fraction of the charging and discharging currents, but this change necessitates decreasing R to increase the charging/discharging currents, which leads to even higher dissipation due to $P=V^2/R$. You would also probably require a zener diode across the auxiliary output rails to correct the overshoot when the auxiliary load decreases. However, for sheer simplicity, this inductorless buck approach is often used to provide very low-power auxiliary rails. You can also level-shift the switching signal to another available regulated rail, and then piggyback the buck cell on top of this rail to give a different low-power regulated auxiliary output voltage with respect to the system ground.

THE LAST COINCIDENCE?

The transfer-function coincidence that forms the basis of the topologies in **Figure 1** invokes the transfer functions of converters that operate in continuous-conduction mode (CCM). It is important to ensure that the converters work in this mode, otherwise the calculations of the intermediate/auxiliary voltage rails are not valid. However, there is yet another transfer-function coincidence, this one involving a stage operating in discontinuous-conduction mode (DCM) discovered by this author.

The advantage of a converter operating in CCM is that there is automatic load regulation. CCM transfer functions do not include I_{OUT} , and thus the duty cycle does not depend on load current. Therefore, for continuous mode, you are mainly concerned about achieving line regulation, and you can achieve this on occasion through the use of clever composites.

Most designers consider DCM equations more complicated, and therefore conveniently overlook or shun them. But these equations do offer certain advantages if understood and used cleverly. Take the equation for the output of a buck-boost in DCM, where L is in μH and f is in Hz:

$$V_{OUT} = \frac{D^2 \cdot V_{IN}^2 \cdot 10^6}{2 \cdot I_{OUT} \cdot L \cdot f} V$$

This equation has the following proportionality:

$$V_{OUT} \propto D^2 \cdot V_{IN}^2.$$

But the duty cycle of a buck converter in CCM has the following proportionality:

$$D \propto \frac{1}{V_{IN}}.$$

Thus, if you use the duty cycle of a buck in continuous mode to drive a buck-boost in discontinuous mode, you can get the dependency on V_{IN} to cancel out:

$$V_{OUT} \propto \frac{1}{V_{IN}^2} \cdot V_{IN}^2 = \text{CONSTANT}.$$

The circuit in **Figure 4** achieves this affect. The slave stage is in parallel to the master, not in series with it as for the earlier boost-buck cascade. In this case, both stages share the input rail.

The design of this circuit also relies on the fact that the output voltage of a discontinuous mode converter at a fixed duty cycle depends on its inductance. So, you can “tune” the slave to have the required output level at its expected maximum load current by carefully choosing the inductance. Within a valid range, this technique provides completely adjustable auxiliary output voltages, something you cannot normally expect from composites based only on CCM stages.

The zener diode at the output of this slave converter is almost completely non-conducting when the slave converter is working at its designed (maximum) load. The efficiency is therefore as high as you normally expect from any conventional switching power converter. However, if the load on the slave decreases, the zener comes into play and starts automatically shunting away the difference between the maximum load current and actual load current, thus maintaining an almost constant effective load as seen by the slave converter. The zener now behaves as a conventional shunt regulator. Therefore, load regulation, which you take for granted when dealing with single or multi-CCM stages, is not automatic. The zener essentially enforces load regulation, but luckily this enforcement needs to happen only at less than maximum loads if you choose the inductance correctly.

The circuit does have line regulation. As the input voltage increases, the feedback loop of the regulated buck converter commands its duty cycle to decrease to maintain output regulation. This decrease in duty cycle is exactly what the discontinuous-mode buck-boost converter requires to regulate its own output almost perfectly.

Finally, you can always produce complete line regulation for both main and auxiliary outputs—one through a deliberate act of feedback and the other that follows automatically due to certain transfer-function coincidences.

The search is not over. While new fundamental topologies may still be a while coming, composites are wide open even now. Think outside the box when trying to generate new auxiliary rails or even when just seeking to enhance the performance of single output converters. □

REFERENCES

1. Middlebrook, R, D, and Slobodan uk, *Advances in Switched-Mode Power Conversion* : Volumes I,II and III. TES-LACO, 10 Mauchly, Irvine, CA 92618
2. www.boostbuck.com
3. www.teslaco.com
4. power.national.com

ACKNOWLEDGEMENTS

Thanks to Jon Cronk for his great technical inputs and Mike He for helping to get this article published. Thanks also to my yet-not-completely-forgotten mentor and boss, Dr GT Murthy, for his constant inspiration. Finally, thanks to my daughter, Aartika, and my wife, Disha.

AUTHOR'S BIOGRAPHY



Sanjaya Maniktala is a principal applications engineer with National Semiconductor Corp (www.national.com). He received his Masters degrees in physics from the Indian Institute of Technology—Bombay and from Northwestern University—Chicago. He has worked professionally for over 15 years in leading power-supply and semiconductor companies in India, Singapore, Germany, and the US. He spends some of his spare time listening to and composing heavy-metal music.