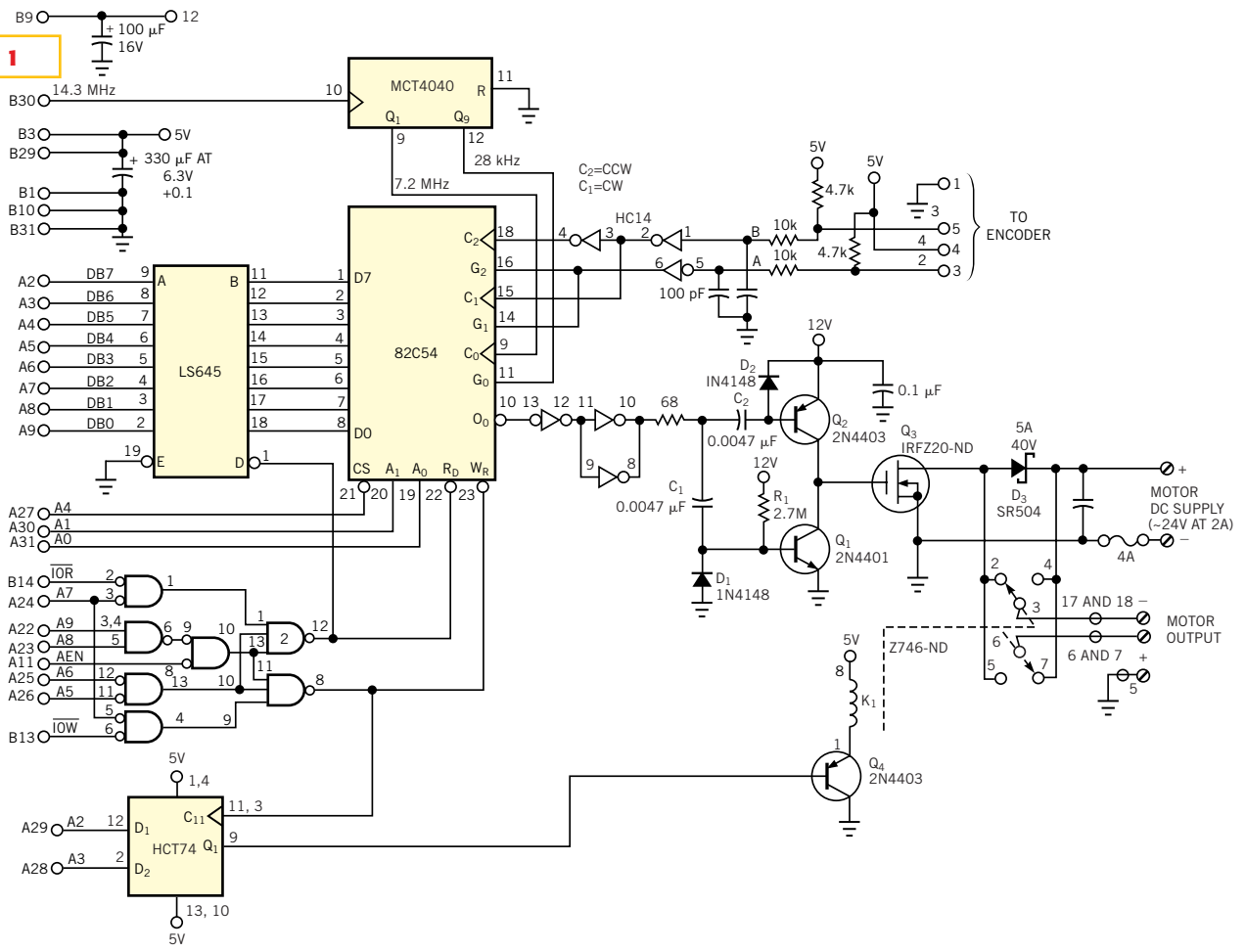

Figure 1



This block of bidirectional logic and a PC comprise a complete motion-control system.