

NEW ACTIVE-PROBE ARCHITECTURES MAKE MULTIGIGAHERTZ SIGNAL-INTEGRITY MEASUREMENTS EASIER AND MORE ACCURATE BUT ONLY FOR THOSE WHO UNDERSTAND HOW THE PROBES WORK AND THE TRADE-OFFS AMONG THE TOPOLOGIES.

Single-ended or differential? That is the question

TRADITIONALLY, USERS of high-bandwidth oscilloscopes and active probes could choose between single-ended and differential probes. To measure single-ended signals (voltages referenced to ground), you used single-ended probes. To measure differential signals (plus versus minus voltages), you used differential probes. So, why couldn't you just buy differential probes and use them to measure both differential and single-ended signals? The truth is that you could, but practical reasons existed for not doing so. Differential probes were more expensive and harder to use and had less bandwidth than single-ended probes.

New probe-system architectures, such as that of the Agilent 113X series, allow either differential or single-ended probing and largely remove the objections to differential probes. The probes provide this capability via interchangeable heads, the types of which are optimized for hand browsing, plugging onto sockets, and soldering in. This construction presents active-probe users with a new question: Should they use a differential or a single-ended probe to measure single-ended signals? Performance and usability trade-offs determine the answer.

Using simplified models (**Figure 1**) and measured data for the Agilent 1134A 7-GHz probe amplifier with solder-in differential and single-ended probe heads (**Figure 2**), you can compare bandwidth, fidelity, and usability; common-mode rejection; repeatability; and size. The probe heads have similar physical-connection geometries, so the main performance differences between them result from the differential versus the single-ended topologies. Probe-performance measurements use the Agilent E2655A deskew/performance-verification fixture and either an Agilent 8720A 20-GHz vector network ana-

lyzer or an Agilent Infiniium DCA (digital-communications analyzer) sampling oscilloscope.

As previously stated, single-ended probes have traditionally had higher bandwidth than differential probes. Is this difference the result of some fundamental law of physics or just a consequence of the practical realities of implementing a differential architecture? To explore this question, consider the simplified model of connection parasitics for both a differential and a single-ended probe (**Figure 1**).

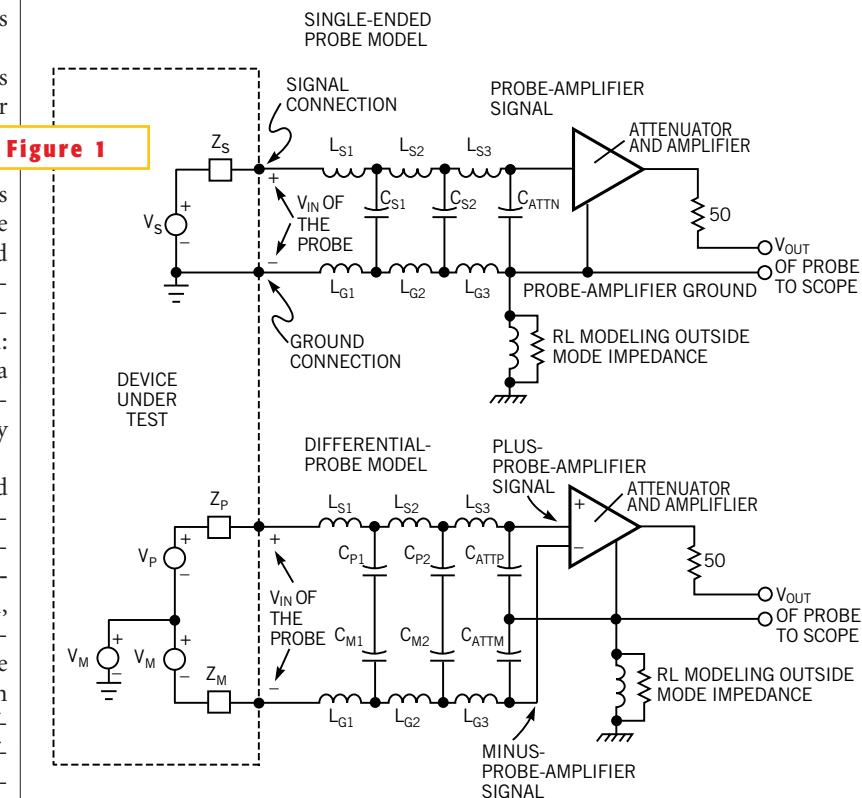

The simplified models of the differential and single-ended probes differ mainly by virtue of the differential probe's placing the ground inductances in series with an amplifier input instead of in series with the probe "ground."

The similarities in the single-ended and the differential probe heads' geometries result in similar inductance and capacitance values. A wide, flat conductor (blade) can reduce the single-ended probe's L_G (ground inductance) value but not dramatically. Note that the differential probe has a tip resistor on both inputs, and the single-ended probe has a tip resistor on the signal input and no resistor in the ground wire (a 0Ω resistor in the actual probe). These resistors are necessary to properly damp the resonance that the input connection's L_s and C_s cause (Reference 1).

Analysis of the single-ended model shows the values of the inductors and capacitors and the significance of L_G . At higher frequencies, the ground inductance allows a voltage to develop between the device-under-test ground and the probe ground, thereby reducing the signal at the attenuator/amplifier input. If you could reduce L_G , the bandwidth would increase.

Reducing the ground inductance requires either shortening the ground connection or making the connection more massive. In the limit, the ideal ground connection is a short, wide conductor plane or a cylinder around the signal connection (creating a coaxial probe connection). These ideal ground connections are generally impractical for real-world probing and would greatly reduce the usability of a single-ended probe. Specifying a single-ended probe in a coaxial fixture that you can't use for actual measurements is also impractical.

Analysis of the differential model driven from a differential signal ($V_{CM}=0$, $V_p=V_m$) shows that, because of the inherent symmetry of the plus and minus signal connections, a plane exists between the connections in which no net signal is present. You can think of this "effective" ground plane as being solidly connected to the device-under-test ground plane and to the probe-amplifier ground. Considering this effective ground plane, you can analyze a half-circuit model in which the area of the signal loop over ground is approximately half that of the full loop and therefore has half the single-ended model's inductance. Analysis of the half-circuit model shows that the bandwidth is much higher. Additionally, the effective ground plane is an ideal ground connection but does not hamper usability.

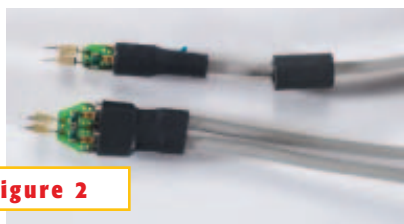

Figure 2

This close-up of single-ended and differential solder-in probe heads shows the single-ended head's greater simplicity and smaller size.

When a single-ended source drives the differential probe, you can use superposition to determine the overall response. In the model, you apply a single-ended signal by making $V_{CM}=V_p=V_m$. For the first term of the superposition, you turn off V_{CM} . For the second term, you turn off V_p and V_m . The first term is simply the response to the single-ended signal's differential component, so the response is the same as previously discussed. The second term is the response to the single-ended signal's common-mode component, so the probe's common-mode rejection determines the response.

If the probe has good common-mode rejection, the overall response to a single-ended signal is just the response to the single-ended signal's differential component. If the probe has inadequate common-mode rejection, the effect shows up in the form of differences between measurements of differential and single-ended signals. The red and green traces in Figure 3 show virtually no difference between these responses.

Figure 3 shows the measured frequency response of the differential probe probing a single-ended signal (green) and the single-ended probe probing a single-end-

ed signal (blue). Both use the same 7-GHz probe amplifier. The bandwidth of the probe is defined as the frequency at which the magnitude of the probe output divided by the probe input is down by 3 dB. Clearly, the differential probe head has significantly more bandwidth than the single-ended probe head (7.8 GHz versus 5.4 GHz). Both probes have good frequency flatness because the connection uses proper damping resistors.

Figure 4a shows the differential probe's measured time-domain response to an approximately 100-psec rise-time input step. Figure 4b shows the single-ended probe's measured time-domain response to an approximately 100-psec rise-time input step. In both figures, the red trace is the probe output, and the green trace is the probe input. Note that the figures do not show the probes' step response but simply indicate how well they can track a 100-psec step. Measuring the step response would require that the input be a perfect, very-fast-rise-time step. In this case, the differential probe would show a faster rise time than the single-ended probe. Both probes track the 100-psec step well.

Common-mode rejection is an issue for both differential and single-ended probes. For a differential probe, a signal common to both the plus and the minus probe inputs should produce no output. For a single-ended probe, a signal common to both the signal and the ground inputs should produce no output. If the output is zero, the common-mode rejection of the applied signal is infinite.

The models for both the differential and the single-ended probes show a resistor and an inductor from the probe at-

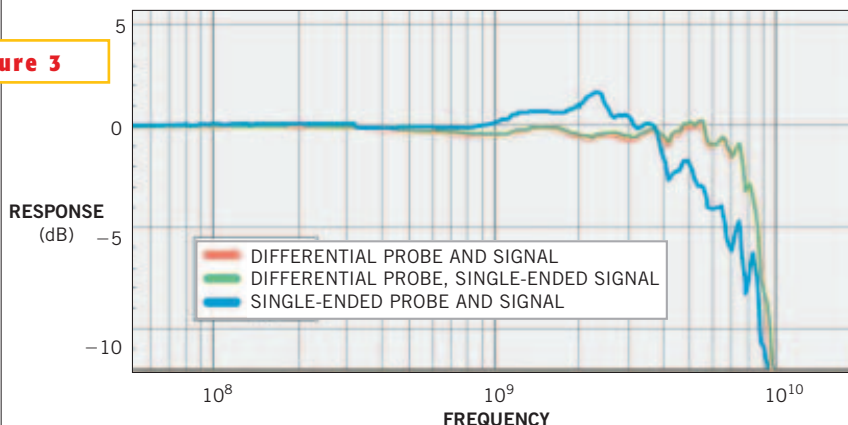

Figure 3

The frequency-response plots of the differential and single-ended probes show the differential probe's broader, flatter response.

tenuator/amplifier ground to “earth” ground (Figure 1). These elements constitute a simplified model of the impedance that the transmission line or, “antenna,” formed by the probe-cable shield and earth ground causes. This outside-mode impedance is important because, when you apply a common-mode signal to the single-ended probe, the L_G values form a divider with this outside-mode impedance. This divider attenuates the ground signal that reaches the amplifier. Because the amplifier’s signal and ground inputs have different attenuation, a net signal appears at the amplifier input and causes an output. The higher the ground inductance, the lower the common-mode rejection becomes, so it’s important when using single-ended probes to keep the ground as short as possible. It is also important to note that this outside-mode signal does not directly affect the inside-mode signal, which is the normal probe output signal inside the coaxial cable. However, the reflected outside-mode signal does affect the probe amplifier’s ground and therefore indirectly affects the inside-mode signal.

When you apply a common-mode signal to a differential probe, both the plus and the minus inputs of the attenuator/amplifier see the same signal. The only output produced is a function of the common-mode rejection of the amplifier, which does not depend on connection inductance.

Does the single-ended or the differential probe exhibit better common-mode rejection when probing a single-ended signal superimposed on common-mode noise? The answer depends on the single-ended probe’s ground-connection inductance and the differential-probe amplifier’s common-mode rejection. For the differential and single-ended probe heads in this example, Figure 5 shows that the differential probe has considerably more common-mode rejection than does the single-ended probe. Therefore, it makes a more accurate measurement in the presence of high common-mode noise. This situation is typical of differential versus single-ended probes unless the single-ended probe has an extremely low-inductance ground connection, which is difficult to achieve in practice. It is important to note that the common-mode rejection of the single-ended probe analyzed here is as good as or better than that of many single-ended probes, be-

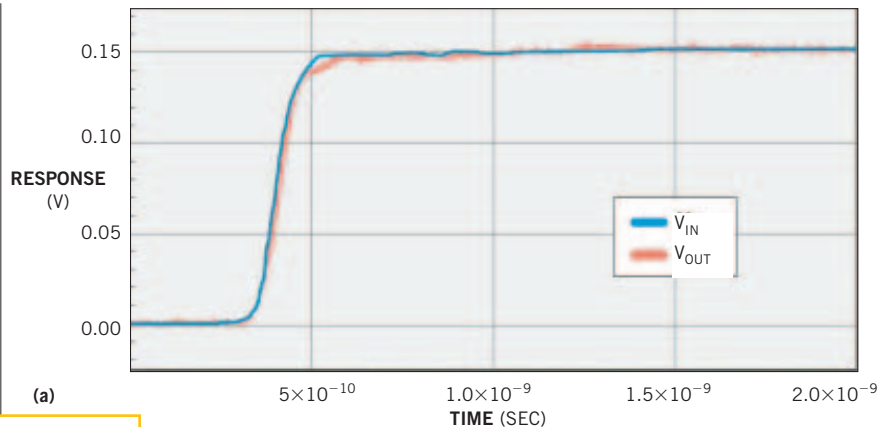
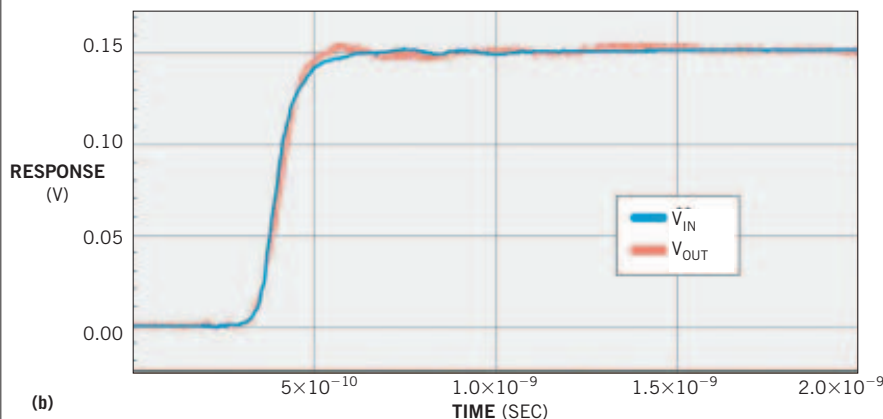

Figure 4



There is little difference between the responses (red traces) of the differential amplifier (a) and the single-ended amplifier (b) to a 100-psec rise-time voltage step, although the differential amplifier response is free of overshoot and settles within 75 psec into a slightly narrower error band.

cause the probe’s ground lead is very short. The common-mode responses of Figure 5 are: DIFFERENTIAL CM RESPONSE = $20 \cdot \log(V_{OC}/V_{IC})$, where V_{IC} is the common voltage on both the plus and the minus inputs, and V_{OC} is the voltage at the probe output when V_{IC} is applied. And SINGLE-ENDED CM RESPONSE = $20 \cdot \log(V_{OC}/V_{IC})$, where V_{IC} is the common voltage on the signal and ground inputs, and V_{OC} is the voltage at the probe output when V_{IC} is applied.

REPEATABILITY

An issue with high-frequency probes is the repeatability of measurements made with the probe. Ideally, probe, cable, and hand position should not cause variations in probe measurements. Unfortunately, however, these factors often affect the measurement, usually because of variation in the outside-mode impedance. This impedance is more complex than the probe models show because of the unshielded transmission line (or antenna)

that probe, hand, and cable positions can greatly affect.

Analysis of the single-ended model with variation in the outside-mode impedance shows that this variation causes the response to change. Additionally, because the outside-mode impedance is also a factor in the common-mode response, variation in this impedance causes the common-mode rejection to vary. The higher the inductance of the ground connection, the worse the response variations become.

Analysis of the differential model with variation in the outside-mode impedance shows that this variation causes little change in the response. The amplifier’s common-mode rejection attenuates any signal that is present on the probe-amplifier ground, greatly reducing variations caused by probe, hand, or cable positions.

In Figure 3, the differential probe has a smoother response than does the single-ended probe. Most of the bumps and

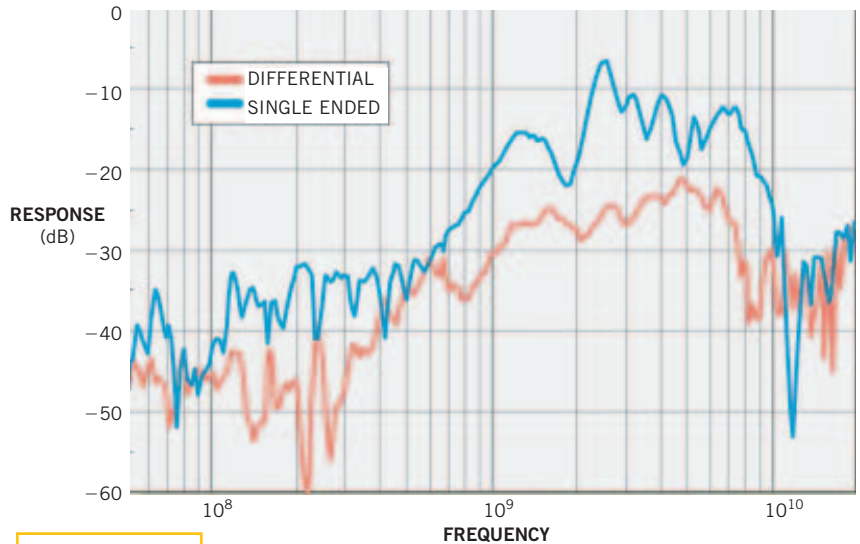

Figure 5 Although both the differential and the single-ended probes provide some common-mode rejection, the differential probe (red) is much better behaved, providing a minimum rejection of more than 20 dB at 5 GHz. The single-ended probe (blue), on the other hand, provides only about 7 dB at 2.5 GHz.

wiggles in single-ended probes' response result from variations in the outside-mode impedance. When this impedance varies, the response varies. Ferrite beads on the probe cable attenuate and terminate the outside-mode signal and reduce the variability of the outside-mode impedance, thus somewhat reducing the effects of probe, hand, and cable positions.

The comparisons between differential and single-ended probes may make you think that the differential probe performs better in every way, whether probing differential or single-ended signals. So, why would you ever use a single-ended probe? A single-ended probe can still make completely acceptable measurements in many situations and may cost less and be smaller because of its less complex tip networks. Small probes can allow probing in confined areas and connecting multiple probes to points that are very close together. From this viewpoint, it appears best to have one probing system that allows either differential or single-ended probing.

Much of the signaling in the electronics industry has migrated from single-ended to differential topologies to mitigate ground bounce, crosstalk, and EMI problems. Differential probing is absolutely necessary for measurement equipment to be useful in this new realm. Differential probes can make better measurements on single-ended signals than can single-ended probes because

the effective ground plane between the signal connections in differential probes is more ideal than are most single-ended probes' usable (noncoaxial) ground connections. New-generation differential probes are easy to use, offer state-of-the-art performance, and are cost-effective for probing both differential and single-ended signals. □

REFERENCE

1. Dascher, Dave, *The truth about the fidelity of high-bandwidth voltage probes*, Agilent Technologies, AN 1404, <http://cp.literature.agilent.com/litweb/pdf/5988-6515EN.pdf>.

AUTHOR'S BIOGRAPHY

Mike McTigue received his BSEE from Arizona State University (Tempe, AZ) in 1979 and began working for Agilent (Hewlett-Packard) in thick-film hybrid-circuit development in the Colorado Springs Technology Center. In 1983, he moved into the oscilloscope R&D lab to work on design and development of next-generation oscilloscopes and probes. McTigue has been involved with the development of the company's sampling-oscilloscope products and MegaZoom real-time oscilloscopes. Recently, he was instrumental in defining and implementing the probing systems needed for next-generation high-bandwidth scopes, including the newest 7-GHz differential/single-ended probe system.