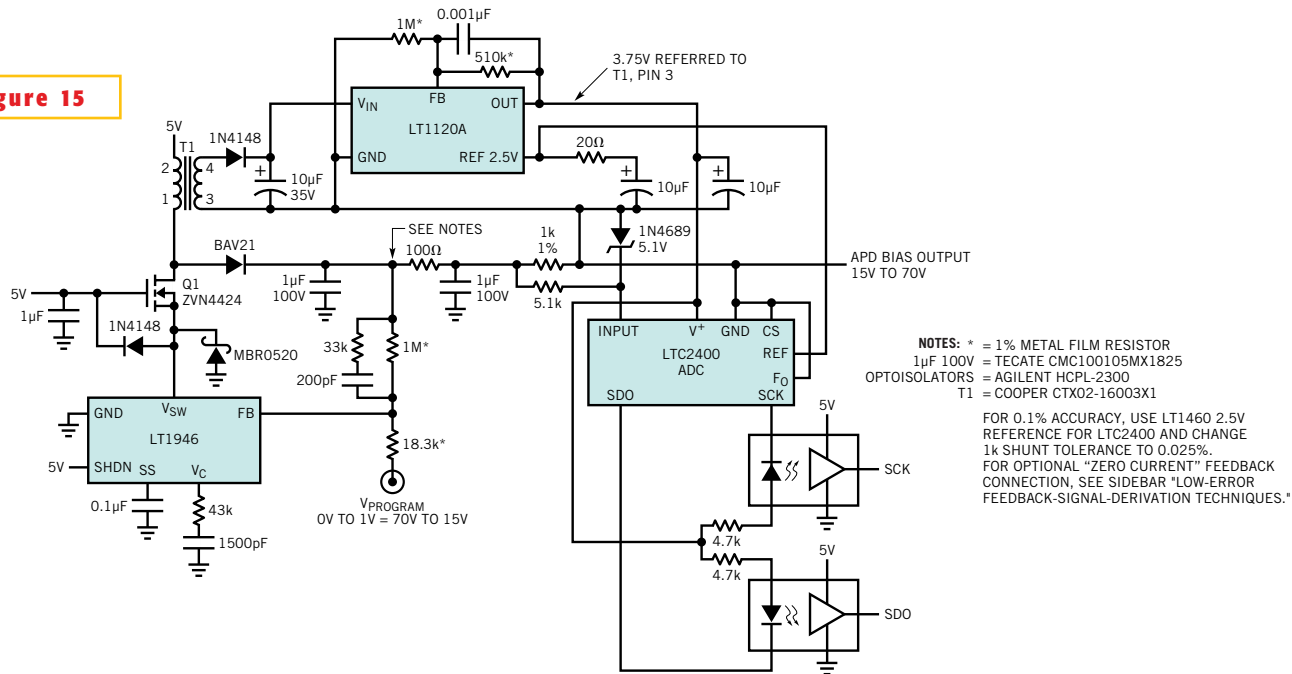

Figure 15



In this APD bias supply with digital-output 2%-accurate current monitor, T₁'s primary winding supplies the APD high-voltage source, and the secondary winding furnishes power to the floating circuitry.