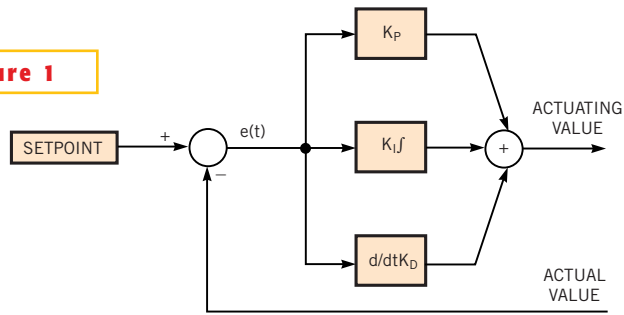

Figure 1



A PID controller calculates an actuating value from proportional, integral, and derivative components.