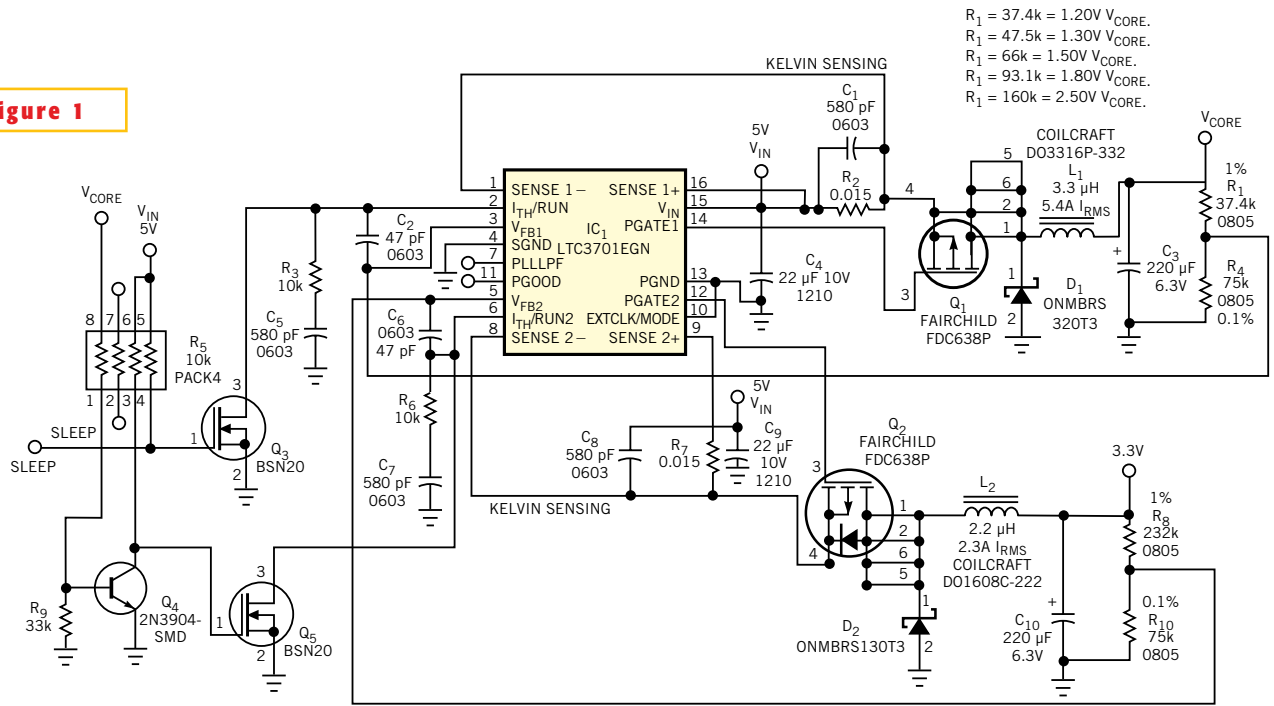

Figure 1



Adding a few transistors to a switching regulator adds power-sequencing and shutdown control to a power supply.