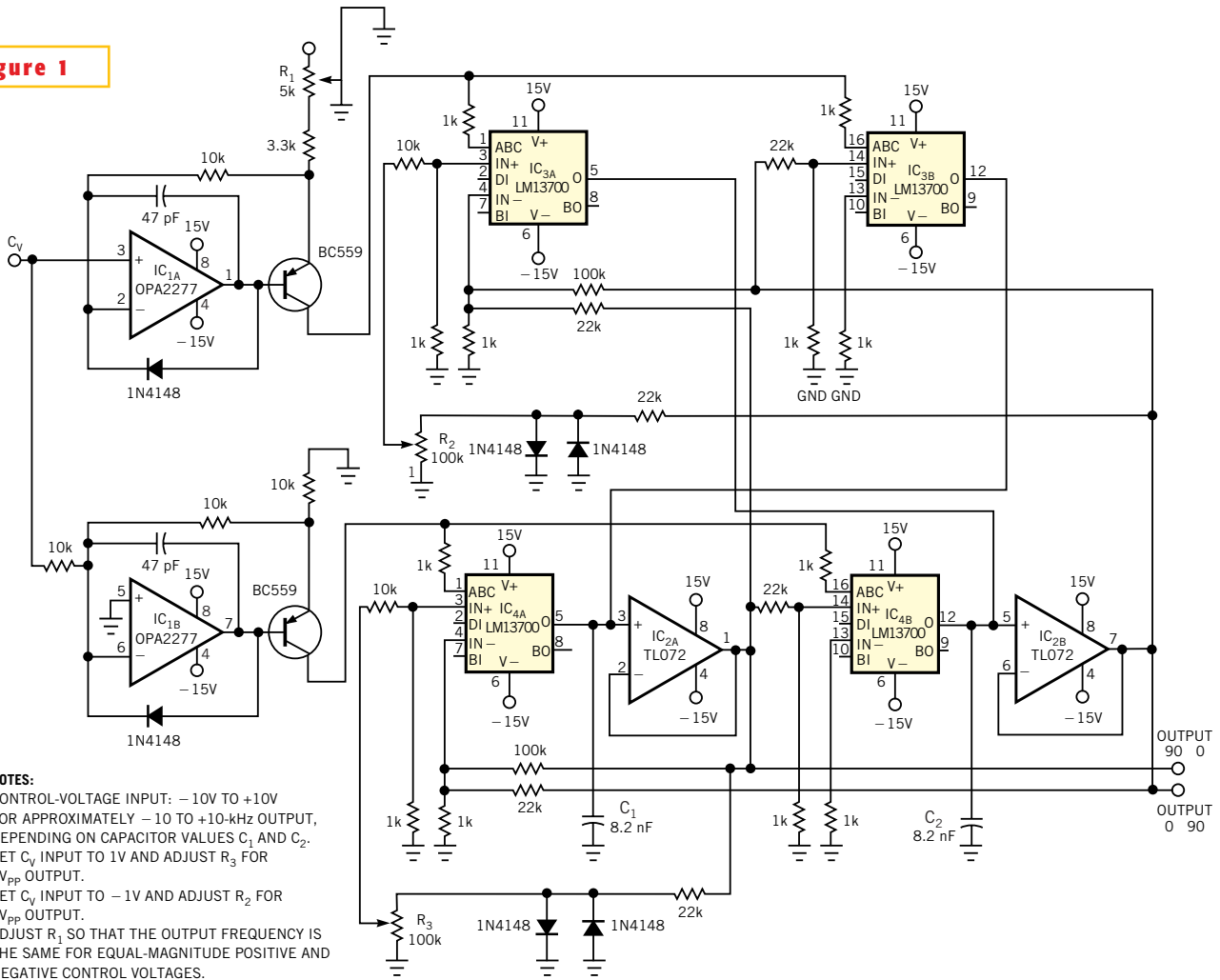

Figure 1



This quadrature-output VCO produces both positive and negative output frequencies.