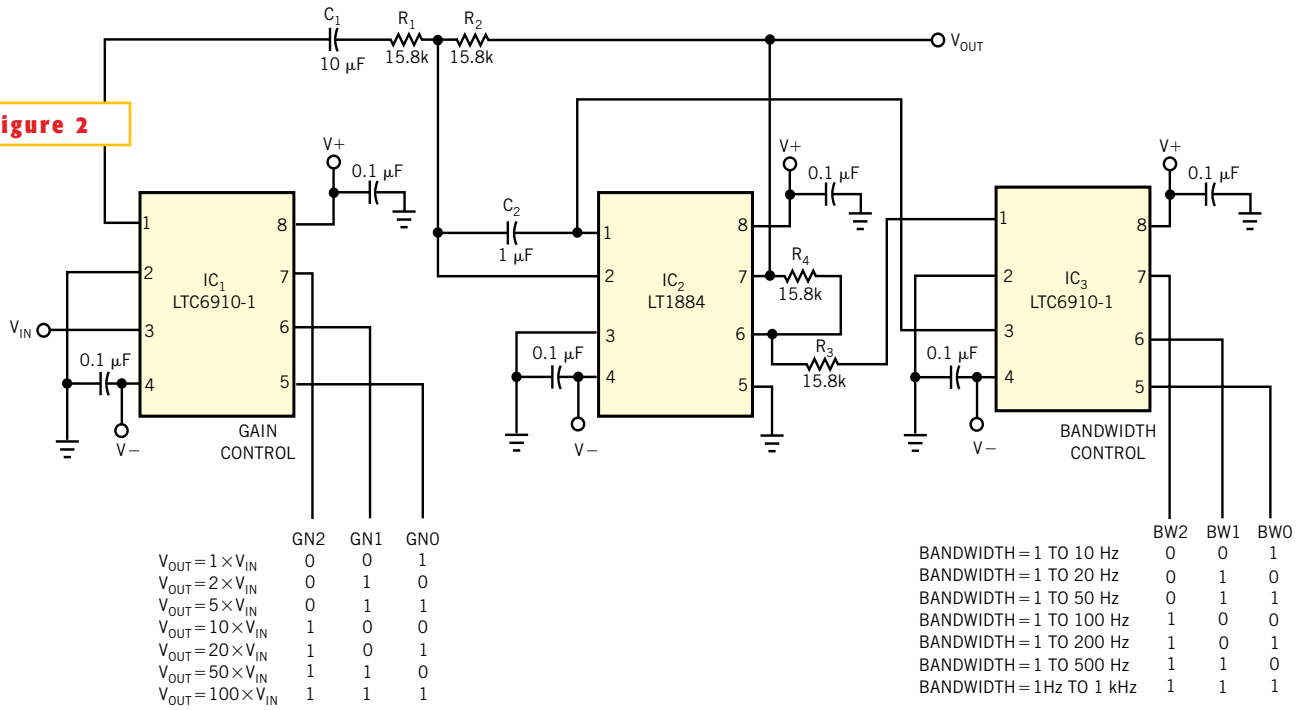

Figure 2



This detailed implementation of the circuit in Figure 1 operates with dual power supplies.