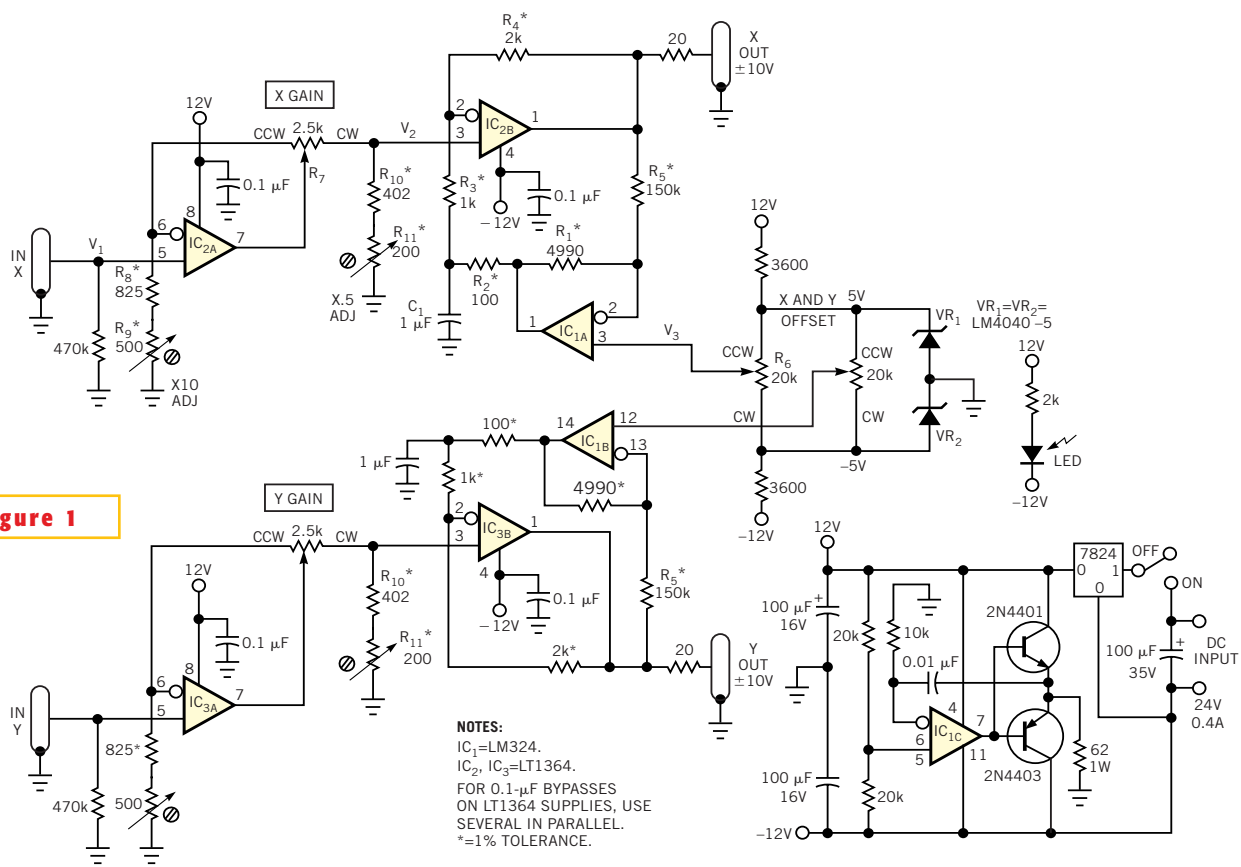

**Figure 1**



In this circuit, positive feedback makes it possible to obtain wide-range dc offset without compromising bandwidth.