



Edited by Bill Travis

Data-acquisition system uses fault protection

Catherine Redmond, Analog Devices, Limerick, Ireland

SENSITIVE SYSTEMS, such as those in aircraft, must withstand fault conditions, thereby avoiding component and system damage, because a sensor failure could cause a catastrophic event to occur. A channel protector, comprising two n-channel MOSFETs connected in series with a p-channel MOSFET, can protect sensitive components from voltage transients in the signal path, whether or not the power supplies are present (Figure 1). The channel protector acts as series resistor during normal operation. If the input exceeds the power-supply voltages, one of the MOSFETs turns off, clamping the output within the supply rails, thus protecting the circuitry in the event of overvoltage or supply-loss conditions. Because channel protectors work regardless of the presence of the supplies, they are also ideal for applica-

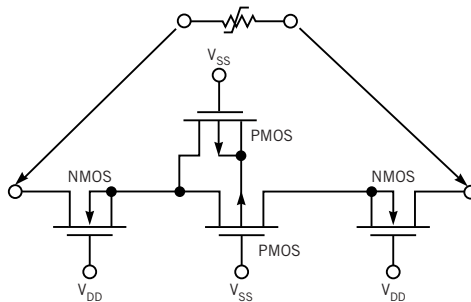

Figure 1 A channel protector can protect sensitive circuitry from voltage transients.

tions in which correct power sequencing cannot be guaranteed and for hot-insertion rack systems. Figure 2 shows an ADG465 channel protector with an input signal that exceeds the power-supply voltage. The protector clamps the output signal, protecting the sensitive components that follow the channel protector.

When a fault condition occurs, the voltage on the input of the channel protector exceeds a voltage set by the supply-rail voltage minus the MOSFET's threshold voltage. For a positive overvoltage, this voltage is $V_{DD} - V_{TN}$, where V_{TN} is the threshold voltage of the NMOS transistor (typically, 1.5V). In the case of a negative overvoltage, the voltage is $V_{SS} - V_{TP}$, where V_{TP} is the threshold voltage of the PMOS device (typically, -2V). When the input of the channel protector exceeds either of these voltages, the protector clamps the output within them. These devices offer bidirectional fault and overvoltage protection, so you can use the inputs or outputs interchangeably. Figure 3 shows the voltages and MOSFET states for a positive-overvoltage event.

The output load limits the current during the fault condition to V_{CLAMP}/R_L (Figure 4). If the supplies are off, the protector limits the fault current to nanoamps. Figure 5 shows how you can use the ADG466 channel protector to protect the sensitive inputs of an instrumentation amp from a sensor fault. In applications that require a multiplexer in

Figure 2

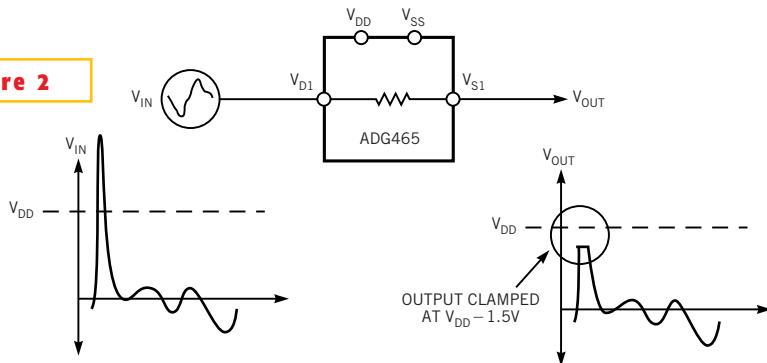

The channel protector clamps overvoltage transients to a safe level.

Figure 3

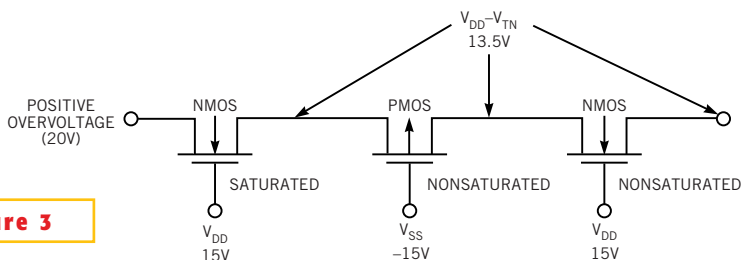

NOTE: V_{TN} = NMOS-THRESHOLD VOLTAGE (1.5V).

The voltages and MOSFET states appear like this during a positive-overvoltage event.

Data-acquisition system uses fault protection	69
Take steps to reduce antiresonance in decoupling	70
Precision level shifter has excellent CMRR	72
Celsius-to-digital thermometer works with remote sensor	74
Quasiresonant converter uses a simple CMOS IC	74
Simple circuit serves as milliohm meter	78
Publish your Design Idea in EDN. See the What's Up section at www.edn.com.	

addition to channel protection, you can use the ADG439F fault-protected, four-channel analog multiplexer (Figure 6). These multiplexers use a series n-channel, p-channel, n-channel MOSFET connection. During fault conditions, the inputs or outputs appear as open circuits, protecting the sensor or signal source as well as the output circuitry. □

Figure 4

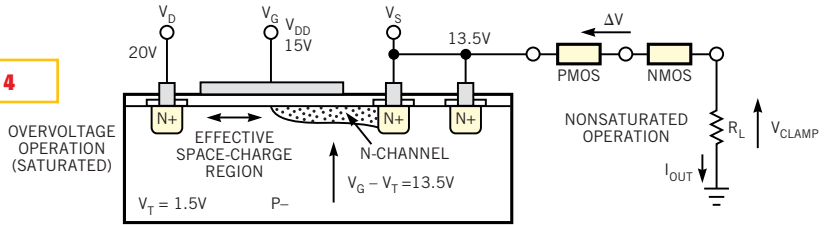

The output load limits the current to V_{CLAMP}/R_L during a fault condition.

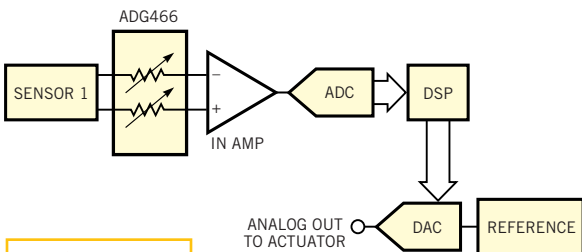

Figure 5

In this circuit, the ADG466 channel protector guards the sensitive inputs of an instrumentation amplifier from a sensor fault.

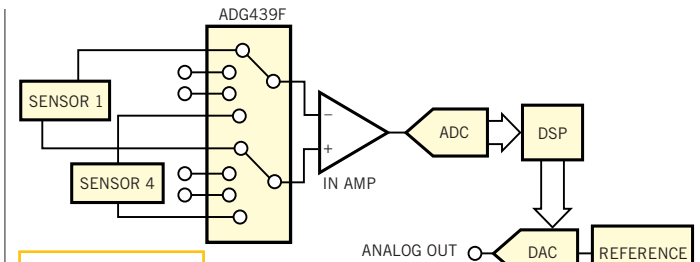

Figure 6

A multiplexer in a data-acquisition system protects the signal source as well as the output circuitry.

Take steps to reduce antiresonance in decoupling

Dale Sanders, X2Y Attenuators, LLC, Farmington Hills, MI

TO MAINTAIN POWER integrity on pc boards, you need multiple capacitors to decouple the power-distribution system. A typical configuration might comprise five capacitors connected in parallel between the power and the ground traces or planes. To provide broadband decoupling performance, assume the individual values of the capacitors are 470, 1, 10, 100, and 220 nF (Figure 1). This parallel network provides 801-nF total capacitance to the power-distribution system. If you measure each capacitor

Figure 2

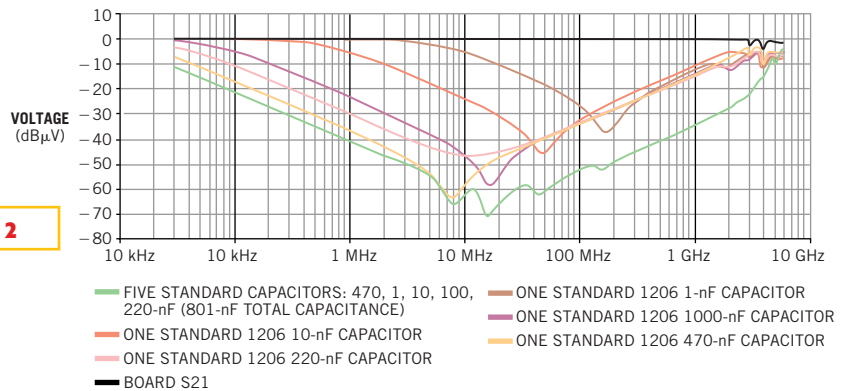

Measurements with a vector-network analyzer reveal undesirable antiresonance effects.

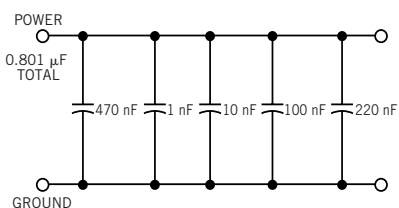

Figure 1

A typical decoupling configuration uses several multilayer-ceramic capacitors connected in parallel.

with a vector-network analyzer, you can identify each capacitor's SRF (self-resonant frequency). Figure 2 is a plot of each capacitor's SRF, as well as the SRF of the overall parallel connection. Each SRF can cause antiresonance in the parallel decoupling configuration. The antiresonance occurs when one capacitor is still capacitive, while another has become inductive.

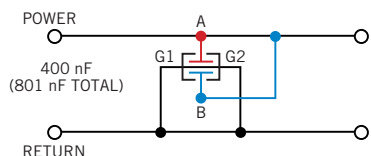
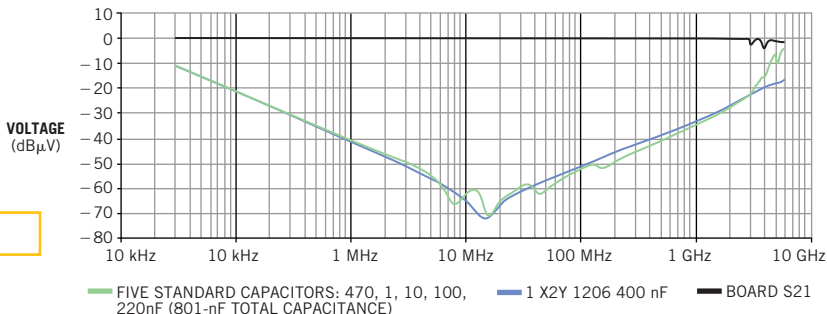

Figure 3

A 400-nF X2Y capacitor yields a total decoupling capacitance of 800 nF.

A way to considerably reduce the antiresonance effects is to use a single 400-nF X2Y capacitor for decoupling. (Capacitors using X2Y technology are available, for example, from Johanson Dielectrics (www.johansondielectrics.com). You measure the capacitance rating for an X2Y component from line to ground; in other words, from an A or a B terminal to either of the G1 or G2 terminals in **Figure 3**. So, the total capacitance a 400-nF X2Y component supplies, connected as in **Figure 3** would be double the capacitance rating, or 800 nF. **Figure 4** shows that a single X2Y capacitor with the same total capacitance as in **Figure 1** provides the same broadband decou-

Figure 4



The single X2Y decoupling capacitor displays no antiresonance effects.

pling as the standard decoupling configuration but without the antiresonance effects. In addition, because X2Y components come in the same package sizes as standard capacitors (1812, 1210, 1206, 0805, and 0603), the use of X2Y components saves pc-board space and reduces layout complexity. □

plung as the standard decoupling configuration but without the antiresonance effects. In addition, because X2Y components come in the same package

sizes as standard capacitors (1812, 1210, 1206, 0805, and 0603), the use of X2Y components saves pc-board space and reduces layout complexity. □

Precision level shifter has excellent CMRR

Ronald Mancini, Texas Instruments, Bushnell, FL

Most designers make level shifters with op amps and 1%-tolerance discrete resistors. Discrete-resistor mismatching limits the op amp's CMRR (common-mode rejection ratio) to 40 dB, so you cannot use op amps in circuits that require high CMRR. Differential amplifiers contain precision matched internal resistors, so ICs such as the INA133 can readily achieve CMRRs of approximately 90 dB. They can offer such high CMRR by trimming internal matched resistors. Assume that each input in the circuit of

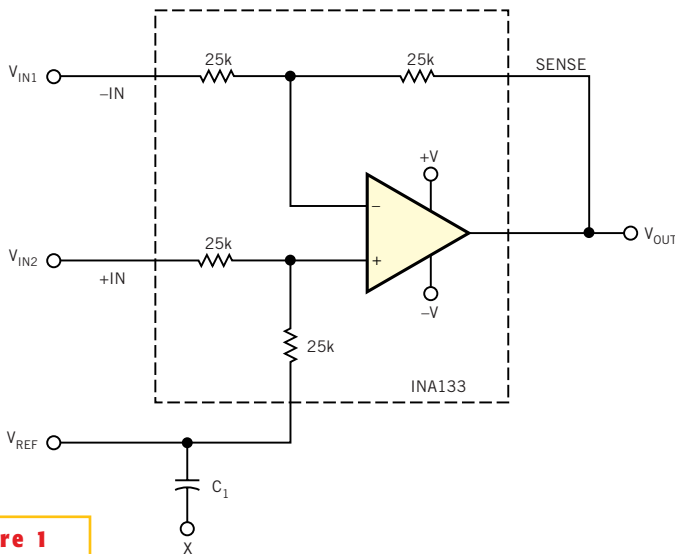

Figure 1

C₁ allows the level shifter to act as a lowpass filter that rejects the reference noise.

Figure 1 has an associated noise voltage (V_{N1} , V_{N2} , and V_{NREF}). The transfer function of the amplifier circuit is $V_{OUT} = (V_{REF} + V_{NREF}) + (V_{IN2} + V_{N2}) - (V_{IN1} + V_{N1})$. Note that the reference voltage shifts the output signal, either single or differential. Once this level shifting occurs, you can turn your attention to the

noise cancellation. Careful cabling and differentially coupling the signal into the differential amplifier's inputs force the noise on the signal inputs to be equal ($V_{N1} = V_{N2}$). The input noise is a common-mode signal, so the differential amplifier rejects it to the best of its ability (nominally, 90 dB). Now, $V_{OUT} =$

$V_{IN2} - V_{IN1} + V_{REF} + V_{NREF}$. Now, you need to eliminate the reference noise to obtain a clean level-shifted signal. You could connect the X end of C_1 to ground to shunt the reference noise to ground, but this solution may be ineffective because the source impedance of the reference is low. When, however, you connect the X end of C_1 to the V_{IN1} signal source, the differential amplifier acts as a lowpass filter and rejects the reference noise. This circuit keeps the input impedance of the differential amplifier low (approximately 25 kΩ for the INA133) to facilitate

matching. Thus, you must keep the signal source impedance low to prevent gain errors. The source impedance should be less than 1/1000 the input impedance to minimize gain error. If this situation doesn't occur naturally, then it is best to buffer the inputs. □

Celsius-to-digital thermometer works with remote sensor

Elana Lian and Chau Tran, Analog Devices, Wilmington, MA

YOU CAN USE a single-supply system to precisely measure the temperature at a remote location with less than 1°C error over a 0 to 100°C range (Figure 1). The circuit includes T_1 , a low-cost AD590 temperature sensor; IC_1 , an AD8541 rail-to-rail amplifier; four resistors; a trimming potentiometer; and an ADC. You can omit the ADC if you need an analog output. You could replace the trimming potentiometer with an AD8400 or AD5273

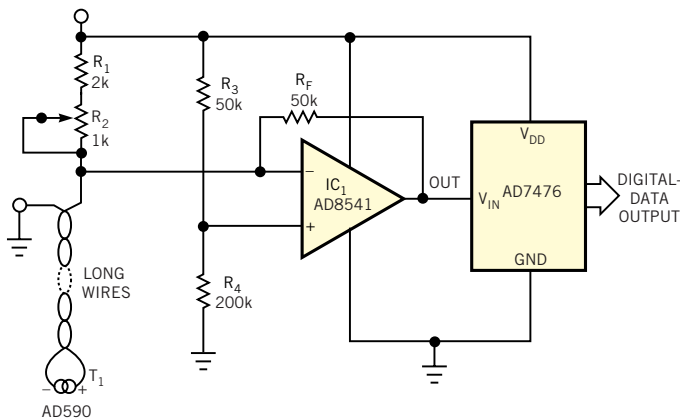

Figure 1

This system precisely measures temperature at a remote location, with less than 1°C error over a 0 to 100°C range.

digital potentiometer for easier calibration. The feedback resistor, R_F , should be a precision resistor to minimize the scale-factor error, but the accuracy of the remaining resistors is not critical. You can choose the grade of the AD590 sensor to achieve the required accuracy.

The AD590 provides an output current proportional to absolute temperature (1 μ A/K). In this application, the circuit offsets and scales the output to provide a full-scale range of 0 to 5V with a scale factor of 50 mV/°C over the chosen temperature range of 0°C—the freezing point of water—to 100°C, the boiling point of water. The AD8541 is a low-cost,

low-power, rail-to-rail operational amplifier. It has a high common-mode voltage range and extremely low bias currents. You can calibrate out its 1-mV typical offset, the resistor, and AD590 errors. The output swing of the amplifier is 25 mV to 4.965V with a single 5V power supply, limiting the output by about 0.5°C on either end.

This circuit can derive its power from a single 5V power supply. The output of the AD590 varies from 273.15 to 373.15 μ A as the temperature varies from 0 to 100°C. The positive input of the AD8541 has an offset of 4V to provide sufficient headroom for the AD590. The series

combination of R_1 and R_2 develops a 1V drop, and you adjust R_2 to provide a nominal current of 353.15 μ A. Thus, the current through the feedback resistor, R_F , varies from -80 to +20 μ A as the temperature varies from 0 to 100°C. The voltage across this resistor varies from -4 to +1V. The 4V offset causes the output voltage of the amplifier to vary from 0 to 5V.

To guarantee the accuracy of 1°C throughout the range, you need to perform a calibration procedure. At a known temperature, such as 25°C, adjust trimming potentiometer R_2 to obtain the desired voltage at the output of the amplifier, 1.250V, or the desired code at the output of the ADC, 400H. Once you perform the calibration, you can calculate the temperature in Celsius at any measured point inside the range by multiplying the output voltage by 20. Because the sensor has a current output, it is immune to voltage-noise pickup and voltage drops in the signal leads; you can thus use it at a remote location. You should use a twisted-pair or shielded cable. □

Quasiresonant converter uses a simple CMOS IC

Francesc Casanellas, Aiguafreda, Spain

FIGURE 1 SHOWS a flyback power supply that has low noise and uses a simple CMOS 4093 IC for its control. The electrical noise of a converter arises mainly when current switches on. Diode recovery and charging parasitic capacitances create high di/dt, which is the main cause of noise. The converter in Figure 1 (pg 76) has a low noise level, because it slowly switches current on at nearly zero

voltage. The converter works in the boundary between discontinuous and continuous mode and switches on when the drain voltage is at its lowest value. To avoid working with low gate voltages, which would cause excessive MOSFET losses, ZD_1 conducts and enables the input gate of the 4093 when the voltage is high enough. When the supply starts, the auxiliary nonisolated winding through D_3

keeps the gate input high. When the MOSFET is on, current increases linearly until the base of Q_3 starts to conduct, and this transistor turns the MOSFET off. The flyback operation then starts, and the primary energy charges the output capacitors. During this phase of operation, D_5 and R_6 keep Q_3 conducting and the MOSFET off. When the energy has discharged,

(continued on pg 78)

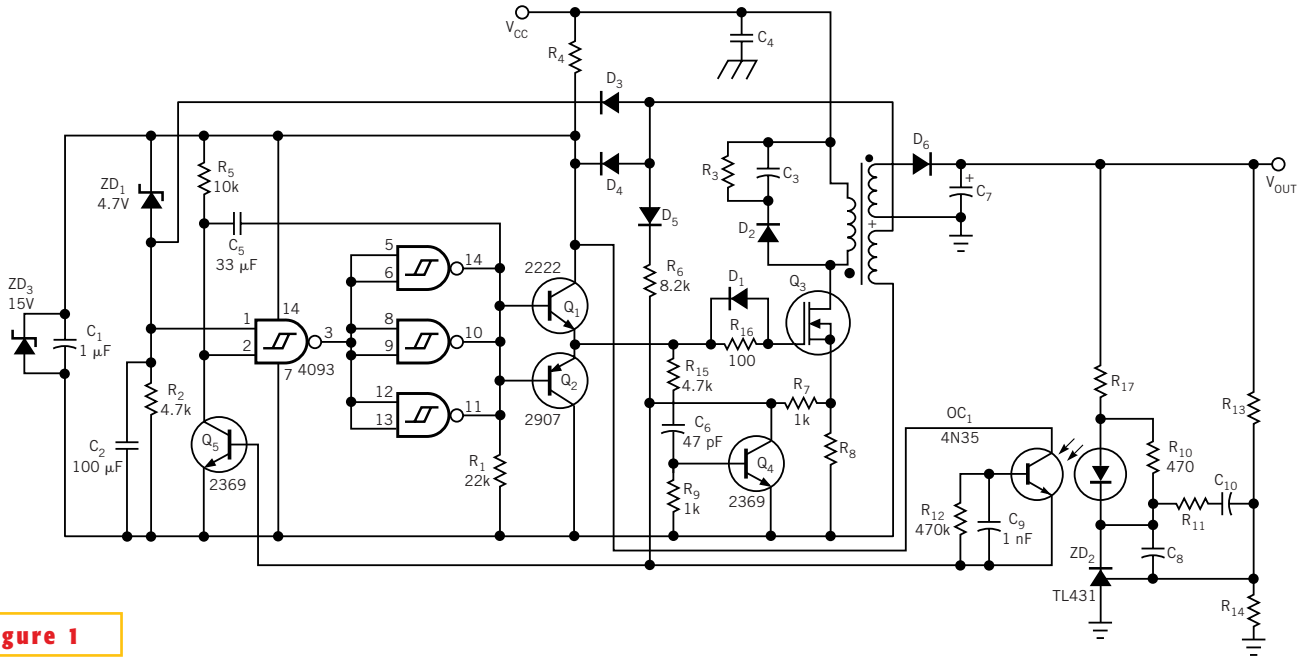

Figure 1

Using a simple CMOS IC, this flyback power-supply circuit exhibits extremely low noise.

(continued from pg 74)

D_3 stops conducting, as do the secondary diodes, so no recovery problems exist.

The time constant of R_3 and C_3 keeps the MOSFET off for a while. The output capacitance of the MOSFET plus the parasitic capacitance of the primary resonate with the primary inductance and the voltage decreases. R_3 and C_3 allow the MOSFET to turn on when the voltage

has reached the minimum value. The values are valid only for this case. The circuit of **Figure 1** not only minimizes turn-on losses, but also reduces electrical noise. Voltage regulation uses traditional techniques, using a TL431. The optocoupler current adds to the shunt current. Because the MOSFET turns on when current is zero, the gate resistor may be high, so parasitic capacitances

charge slowly, further reducing switching noise. The circuit around Q_4 is optional; you can use it in most power supplies. It kills the current glitch when Q_3 turns on. It is more effective than the usual RC circuit, and it allows a low duty cycle at low loads. Note that many of the component values in **Figure 1** are undesignated; you should determine these values to fit the application. □

Simple circuit serves as milliohmmeter

AM Hunt, Lancaster Hunt Systems Ltd, Shepperton, UK

WHEN I WAS recently debugging a design, I discovered that a short circuit existed from a ground plane to a power plane. I did not have access to a milliohmmeter or an equivalent tester for locating this type of short circuit. So, I logged onto the Internet to find an easily constructible milliohmmeter. I

found the answer in a manufacturer's data sheet, which outlined the basic four-wire method of making low-resistance measurements. The method uses a voltage-reference IC as the input stage for a controlled constant-current source. A quick dig in the old component bucket revealed a supply of LM317 variable-volt-

age regulators. These ICs provide 1.25V between their V_{OUT} and V_{ADJ} terminals, a constant voltage to attack the constant-current problem. The other problem to attack was the output-voltage range of the constant-current source. The circuit I was working on used a 3.3V supply, so I had to limit the voltage to 3.3V. An

LM317, configured as a constant-current source, delivers an output voltage equal to the input if the output resistance is too high. Because I wanted to use a bench supply or a 9V battery, the voltage would fry any 3.3V logic on the board. Ideally, I wanted voltage to be limited to 1.5V. So, I came up with the configuration in **Figure 1**.

IC₁ controls the base of the npn Darlington transistor, Q₁. The IC regulates the voltage across the selected resistor to form the constant-current source. The current source delivers either 10 or 100 mA, depending on which emitter resistor is in the circuit. The purpose of S₁ is to give longer battery life. You can calibrate the current source by strapping a resistive load be-

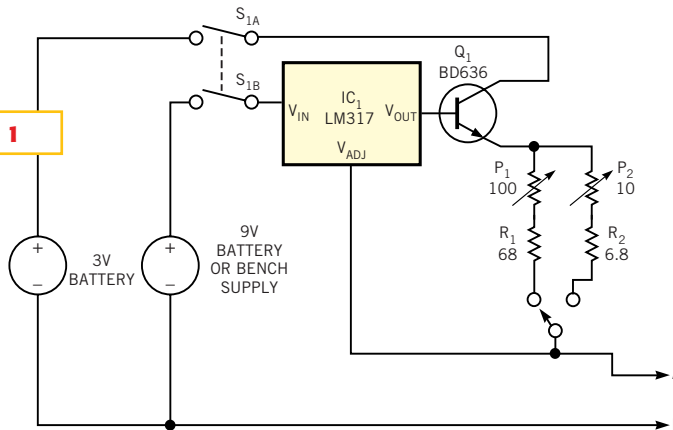

Make your own milliohmmeter, using a voltage-regulator IC and some resistors.

tween test points A and B and measuring the voltage across the resistor using a DVM (digital voltmeter). I used 5 and 10Ω and set one S₂ position for 10 mA and the other for 100 mA. To measure a small resistance, you attach test points A and B across the resistance. You set the

DVM on a millivolt range. The DVM reads a voltage that is proportional to the resistance under test. If you calibrate the circuit as suggested, then the reading is 10Ω/V on the 100-mA range and 100Ω/V on the 10-mA range.

To track down pc-board short circuits, attach the unit with test points A and B across the suspected shorted signals. Attach one DVM probe to test point A and use the other to probe the circuit. Constant voltage along a trace indicates that no current is flowing and that the trace is not the source of the short circuit. Look for high readings on the trace with the low reading and low readings on the trace with the high reading, to locate the source of the short circuit. □