

Edited by Bill Travis and Anne Watson Swager

## NCO technique helps $\mu\text{C}$ produce clean analog signals

Steve Ploss, Veridian Corp, Wright Patterson AFB, OH

**A** RECENT DESIGN IDEA described a method for producing an analog voltage from one digital output of a  $\mu\text{C}$  (“Generate an analog signal with a  $\mu\text{C}$ ,” *EDN*, Oct 22, 1998, pg 108). The method involves generating a PWM output with a controlled duty cycle and filtering the switching waveform with a simple single-pole RC filter. Although this method provides an accurate dc output with 8 bits of resolution, it requires a filter with a low cutoff frequency to reduce the ripple to less than 1 LSB.

An alternative method doesn’t have this problem. The circuit in **Figure 1** and the corresponding control program borrow a technique from direct digital synthesizers. The technique consists of a numerically controlled oscillator (NCO) that distributes the duty cycle as evenly as possible across the main period of the output, which is 256 clocks for both the NCO and PWM approaches. **Figure 2a** and **Figure 2b** illustrate the operation of

**Figure 1**

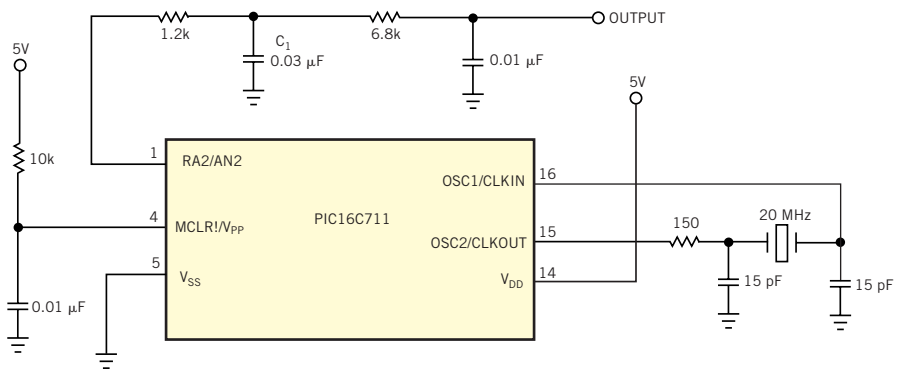

**A numerically-controlled-oscillator (NCO) technique allows a  $\mu\text{C}$  and a handful of passive components to output analog signals that, after filtering, have a ripple amplitude that is constant over changes in duty cycle.**

the NCO and the PWM methods, respectively, with the duty cycle set to 10/256. **Figure 2a**’s NCO digital output has the same duty cycle as **Figure 2b**’s PWM output but distributes the duty cycle evenly across the period.

The benefit of the NCO is that the ripple amplitude after filtering is almost constant with changes in the duty cycle. In contrast, the PWM method has a ripple amplitude equal to that of the NCO approach at the lowest duty cycle, and the ripple worsens at midscale.

**Figure 3** compares the expected output for each of the two methods using the same duty cycle as before, 10/256. A simple IIR filter that simulates a single-pole RC low-pass filter, performed the filtering. The time constant for this filter is 256

clocks. This **figure** shows that the NCO output has much lower ripple than the PWM output at this output duty cycle (**Figure 3a**). As the DAC value approaches midscale, which corresponds to a duty cycle of approximately 128/256, the PWM ripple gets progressively worse, but the NCO ripple improves by as much as a factor of 2 (**Figure 3b**).

The accompanying listing to **Figure 1** runs on the PIC16C711, but, because the routine doesn’t use the ADC and the TMR0 interrupts, you can use it with other processor types. (You can download the program from *EDN*’s Web site, [www.ednmag.com](http://www.ednmag.com). At the registered-user area, go into the Software Center to download the file from DI-SIG, #2346.)

The DAC routine uses only two regis-

NCO technique helps $\mu\text{C}$ produce clean analog signals .....	129
$\mu\text{C}$ generates musical sounds .....	132
Continuity buzzer is frugal with power .....	134
Stereo jack adds no-cost power/logic control .....	136
S/H circuit minimizes aperture .....	140

ters; the phase accumulator and the holding register form the DAC input value. Two additional registers provide sine-wave values to the DAC routine. On initialization, the phase accumulator sets to zero, and the DAC value sets to mid-scale (0x80). On each update, the value of the DAC register adds to the phase accumulator. When the phase accumulator rolls over—an event signaled by the setting of the carry bit—the circuit sets the output high for one update. The process then continues indefinitely. To generate a sine wave, the program counts the number of times it loops and every 32nd time it retrieves the next value from the look-up table. The table holds 16 values of a full cycle, so the period of the sine wave is 512 times the loop time, plus a small amount of time for the branch out of the loop. With a 20-MHz crystal, the loop time is approximately 3.5  $\mu$ sec, and the sine-wave frequency is approximately 625 Hz.

To output an analog waveform, you need only to change the value of the DAC register. This change can happen at any time. The analog output almost immediately starts updating. When you use this method for your own application, remember to update the DAC output as often as possible to lower the ripple amplitude. The rate need not be precise, because you are merely setting a duty cycle—the period of which is relatively unimportant. More likely, you need to control the period of your analog waveform.

If you can afford to use a  $\mu$ C with a timer interrupt, it's best to use that interrupt to determine when to change to the next DAC value. The rest of the time, you can continuously update the output. If you don't want to use the timer interrupt, you can update the DAC as part of a polling loop, as shown in this example, waiting for a loop counter to reach a predetermined value before changing the DAC value. However, you may want to make sure that the branch from the polling loop always takes the same amount of time, so that the DAC-value changes occur at a constant rate. Also, if the branch is going to take a comparatively long time, consider setting the output bit to a high-impedance state for the duration of the branch. If

**Figure 2**

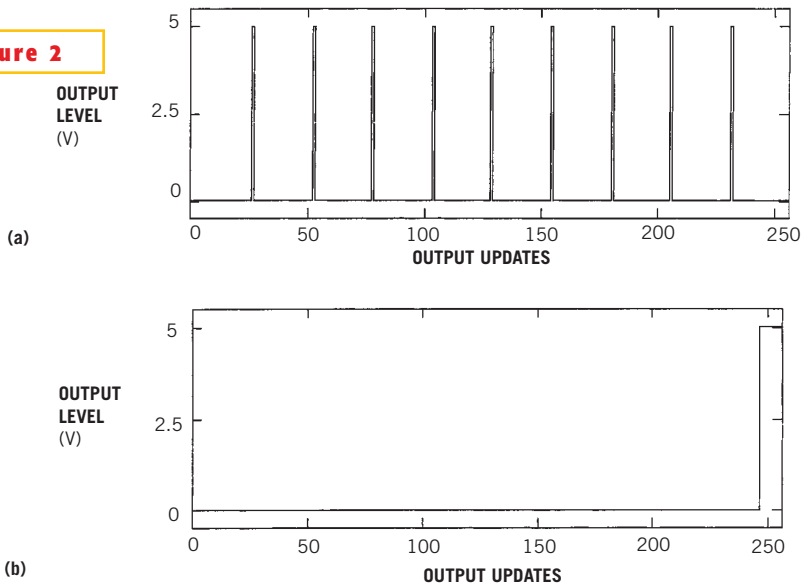

The NCO digital output (a) has the same duty cycle as the PWM output (b) but distributes the duty cycle evenly across the period.

**Figure 3**

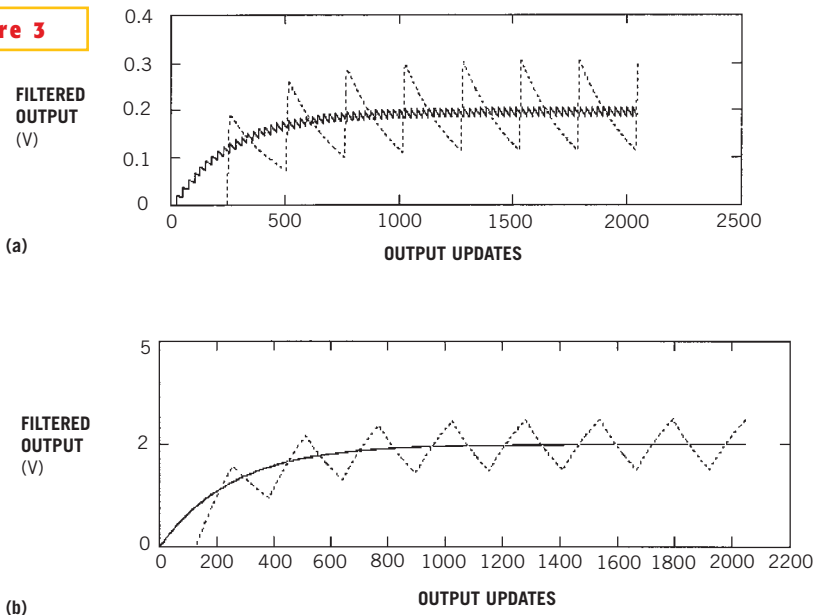

The output ripple that results from the numerically-controlled-oscillator (NCO) method—for example, at a duty cycle of 10/256—is much lower than that of the PWM method (a). As the DAC value approaches mid-scale—a duty cycle of approximately 128/256—the PWM ripple gets progressively worse, but the NCO ripple improves by as much as a factor of 2 (b).

you do not take this precaution, the output will hold the last value—whether high or low—for the duration of the branch and could produce a transient on

the filter output. (DI #2346)

TO VOTE FOR THIS DESIGN,  
CIRCLE NO. 402



the standard address list of the registers and the bytes of the  $\mu$ C. You can download **Listing 1** and its associated files from EDN's Web site, [www.ednmag.com](http://www.ednmag.com). At

the registered-user area, go into the Software Center to download the files from DI-SIG, #2336. (DI #2336).

To VOTE FOR THIS DESIGN,  
CIRCLE No. 403

### LISTING 1—ROUTINE FOR GENERATING MUSICAL SOUND

```

**** MUSICAL SOUND GENERATING
*****
*NOLIST
$INCLUDE "std-j1a.asm"
*LIST
*I/O PORTS
snd equ pA1
* CONSTANTS
do equ 189T
re equ 168T
mi equ 152T
fa equ 142T
sol equ 126T
N equ 26T ;number of notes in the melody
ND equ 100T ;number of each note repetition
aDUR equ ROMend-N ;pitch duration table address
aMEL equ ROMend-N-N ;note pitch table address
*VARIABLES
ORG RAM
NR rmb 1 ;note pitch register
DR rmb 1 ;pitch duration register
NDR rmb 1 ;note duration register
memx rmb 1
mem1 rmb 1
*INITIALIZATION
ORG MOR
fcb %00100000 ;resistor ocs
ORG ROM
init rsp ;reset SP
lda #fff
sta ddrA
clr prtA
*MAIN PROGRAM
main jsr dly1s ;delay 1 sec
jsr melody ;start music
jsr dly1s
jsr dly1s
bra main
.page
*MELODY SUBROUTINE
MELODY clrX ;0 -> X
m1 lda aMEL,x ;load the note pitch
sta NR ; into NR register
lda aDUR,x ;load the pitch duration
sta DR ; into DR register
lda #ND ;load the number of note
sta NDR ; repetition into NDR reg.
stx memx ;save X in memory
m2 jsr note ;generate the note
dec DR
bne m2
bclr snd,prtA ;make a pause 10ms after
ldx #100T ; each note
jsr DLY01x
ldx memx ;reload X from memory
cpx #N-1 ;are there any more notes?
blo m3
m3 rts ;end Melody Subroutine
incx ;go to next note
bra m1
*****
note bset snd,prtA ;start a note
ldx NR
jsr DLY01x
bclr snd,prtA
ldx NR
jsr DLY01x
lda NDR
beq n0
dec NDR
bra note
n0 rts ;end a note
.page
DLY01x lda #2 ;delay 0.01X ms
rep0 decA
bne rep0
decx
bne DLY01x
rts
*****
dly1s lda #10T ;delay 1 sec
sta mem1
lp1 jsr dly01s
dec mem1
bne lp1
rts
dly01s lda #128T ;delay 0.1 sec
lp2 clrX
lp3 decx
bne lp3
deca
bne lp2
rts
*****
*Put tables into memory
org aMEL
fcb MI,MI,MI,MI,MI,MI,SOL,DO,RE,MI,
fcb FA,FA,FA,FA,FA,MI,MI,MI,MI,RE,
fcb RE,MI,RE,SOL
org aDUR
fcb 2,2,4,2,2,4,2,2,2,8,
fcb 2,2,2,2,2,2,1,1,2,2,2,4,4
*****
org vectors+6
fdb init ;set restart address
.end
.nolist

```

## Continuity buzzer is frugal with power

Hans Kroboth, EEC, Nesconset, NY

**T**HE CONTINUITY DETECTOR in **Figure 1** is based on W Dijkstra's "Fleapower circuit detects short circuits" (EDN, July 2, 1998, pg 122). The buzzer

indicator allows you to devote full attention to making the connection without having to observe an LED. The circuit also consumes less power than Dijkstra's

circuit. Power comes from two AA or AAA cells, which last for a period equal to their shelf life. Current consumption is less than 2.5 mA when the circuit de-

tests continuity and less than 1.7 mA for an open circuit. Open-circuit voltage is less than 100 mV, and short-circuit current is less than 1 mA. You can use a number of op amps for IC<sub>1</sub>, provided that the specs indicate rail-to-rail operation with a low-voltage single supply.

The piezo oscillator driver uses only 700  $\mu$ A when operating and consumes only Q<sub>1</sub>'s leakage current when it is not operating. This type of piezo transducer is a passive, resonant-feedback type,

which provides high power efficiency and low-voltage operation. With R<sub>x</sub> values greater than approximately 12 $\Omega$ , the inverting input of the op amp is at a higher potential than that of the noninverting input. The resulting output is 0V plus the saturation voltage of the output stage. This output provides no bias current through R<sub>5</sub> and thus keeps Q<sub>1</sub> cut off. With R<sub>x</sub> values lower than approximately 12 $\Omega$ , the inverting input of the op amp has a potential lower than that of the

noninverting input. The resulting output is 3V minus the saturation voltage of the output stage. The approximately 3V output biases Q<sub>1</sub> into the linear region. Q<sub>1</sub> and the piezo transducer, with their associated feedback, oscillate at their resonant frequency. Most transducers and the listed op amps operate with supply voltages as low as 2V. (DI #2350).

TO VOTE FOR THIS DESIGN,  
CIRCLE NO. 404

**Figure 1**

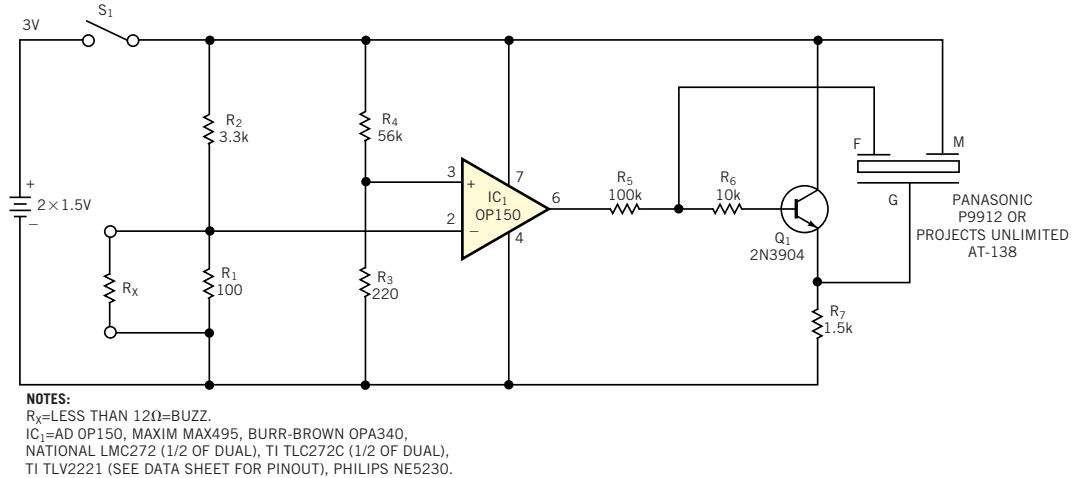

This audible-signal continuity tester consumes little power and allows you to detect opens and shorts without observing an LED.

## Stereo jack adds no-cost power/logic control

Gary O'Neil, IBM Microelectronics, Research Triangle Park, NC

**M**ANY BATTERY-POWERED devices use peripherals that require only two conductors to complete their interfaces. You can use stereo phone jacks and monaural plugs to perform power or logic-control functions in addition to completing their required I/O connections. Monaural plugs short-circuit the ring and sleeve of stereo jacks. You can place the ring connector, normally considered a redundant ground return, into

service as an spst switch. A simple wireless transceiver illustrates how you can use stereo jacks for switching with monaural plugs, stereo plugs, or both (Figures 1 and 2). Using the design in Figure 1, you can connect the battery return to the ring of stereo jacks serving one or more I/O devices. The circuit in Figure 2 connects the returns of individual circuits to the ring.

With this scheme, power control be-

comes automatic with the plugging and unplugging of devices using monaural plugs, by virtue of the ring-to-sleeve short circuit. Three examples illustrate the principles of operation. In the first example, the transceiver comprises a transmitter, a receiver that contains an audio amplifier, a battery supply for power, and two stereo phone jacks (J<sub>1</sub> and J<sub>2</sub>) for transmitter modulation and audio output, respectively (Figure 1). J<sub>1</sub>'s tip con-

nection carries the modulation input to the transmitter. This input could be a keying line for CW (continuous modulation, for Morse code); a digital modulation interface; or an analog input, such as in a wireless microphone. The output of the audio amplifier (demodulated digital data, control tones, voice, music, or other) connects to the tip of  $J_2$ .

With no peripheral attached, the negative side of the battery floats, with no return to ground. Therefore, the transceiver receives no power. The negative side of the battery connects to the rings of all jacks you want to use for power-on/off control. Inserting a telegraph key, digital-modulation device, or microphone into  $J_1$  via a monaural plug connects the negative side of the battery to ground via the ring-to-sleeve short circuit, and the transceiver turns on. Plugging an earphone or speaker into  $J_2$  via a monaural plug completes an alternate, or redundant, ground return for the battery. Thus, inserting a plug into either jack completes the power path to all the transceiver circuits.

In another example, you can selectively isolate and enable circuits using stereo jacks to maximize power conservation. When you plug a peripheral into  $J_1$ , the circuit in **Figure 2** enables only the transmitter circuit. When you plug a peripheral into  $J_2$ , the circuit enables only the receiver and audio-amplifier circuits. The return paths of the individual circuit functions float and connect to the ring of one or more stereo jacks associated with a peripheral that requires those circuit functions to operate. The battery permanently connects to the same ground reference as the sleeve of all jacks. You need both the receiver and audio amplifier to operate during the receive function; they share a common return path with the ring of  $J_2$ . You enable these circuits by inserting an appropriate peripheral (speaker or headphone) into  $J_2$  via a monaural plug.

In the final example, you can further conserve power in specialized cases featuring remote on/off control, such as for transmitter on/off keying (**Figure 2**). You use insert a stereo plug into  $J_1$  to remotely locate the ring/sleeve connection. The ring/sleeve path to the negative side of the

**Figure 1**

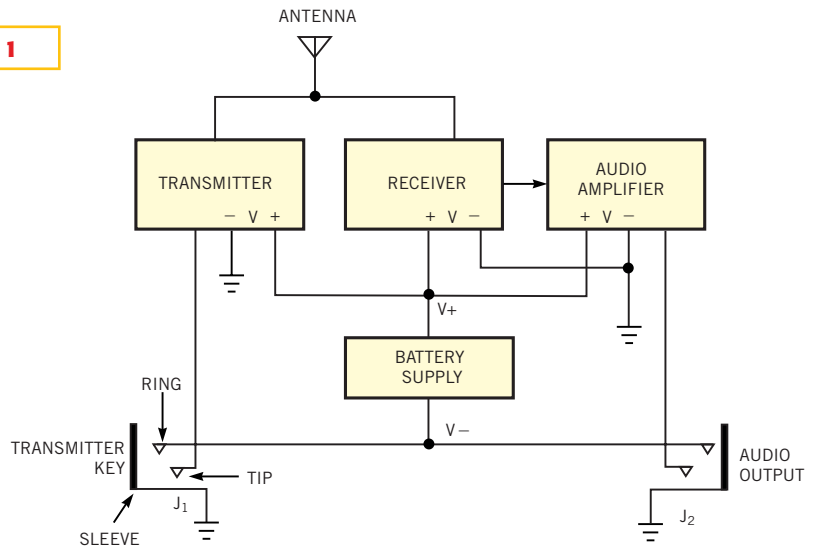

Inserting any monaural plug completes the battery's ground-return path, thus enabling all circuits in the transceiver.

**Figure 2**

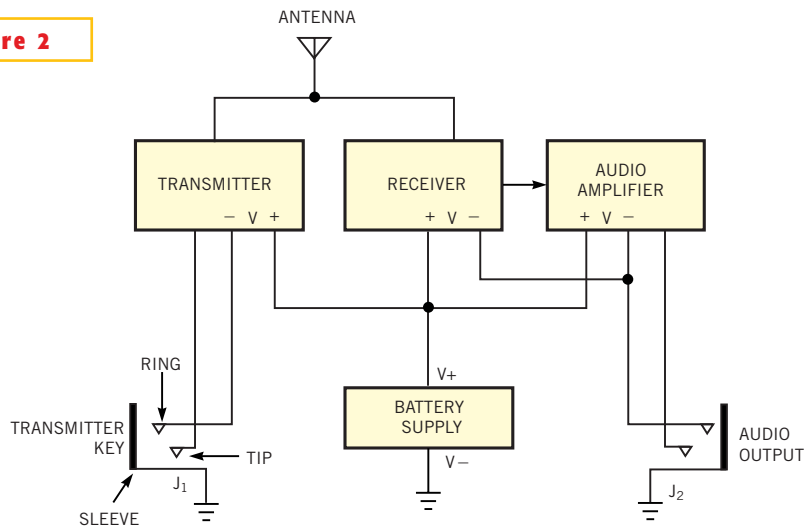

The absence of a peripheral plug breaks the ground return for either the transmitter or the receiver/audio-amplifier portion of the transceiver.

battery is incomplete until a peripheral switch or a key closes. You can define a ring/sleeve, tip/sleeve, or ring/tip/sleeve short circuit and use it to complete the desired electrical connections. In this example, the circuit consumes power only

when you enable the transmitter; thus, you have maximum control of battery resources. (DI #2355).

TO VOTE FOR THIS DESIGN,  
CIRCLE NO. 405

# S/H circuit minimizes aperture

John Guy, Maxim Integrated Products, Sunnyvale, CA

**C**ONVENTIONAL SAMPLE-AND-HOLD (S/H) circuits use one hold capacitor that charges during the track phase and disconnects during the hold phase. The voltage that the capacitor holds usually drives an A/D converter that operates synchronously with the S/H control signal. This approach can sometimes place excessive demands on the S/H circuit's bandwidth and settling capabilities. You can improve performance by using two hold capacitors to implement continuous sampling (Figure 1). One capacitor or the other is always sampling the input signal, and the output is always the held value. A phase-reversal switch (IC<sub>1</sub>) interconnects the input, output, and hold capacitors.

When the control signal (Clock) is low, the input connects to the C<sub>2</sub> hold capacitor via R<sub>2</sub>. C<sub>2</sub> and the on-resistance of the switch form a 160-nsec time constant, providing ample time to charge the capacitor. When Clock goes high, C<sub>2</sub> connects to the output via the lower switch,

and C<sub>1</sub> connects to the input. Many factors affect the performance of this circuit. Droop rate on the hold voltage, for example, is a strong function of the output-load impedance. If the A/D-converter load is excessive, you should add a buffer amplifier at the output of the S/H circuit. The hold capacitors should be low-dielectric-absorption types, and the phase-reversal switch should specify low charge

injection and make-before-break timing. Figure 2 (input and output at 100k samples/sec) and Figure 3 (detail at 400k samples/sec) show good performance with the values shown. The high-speed transitions exhibit little overshoot or ringing. (DI #2354).

TO VOTE FOR THIS DESIGN,  
CIRCLE NO. 406

Figure 1

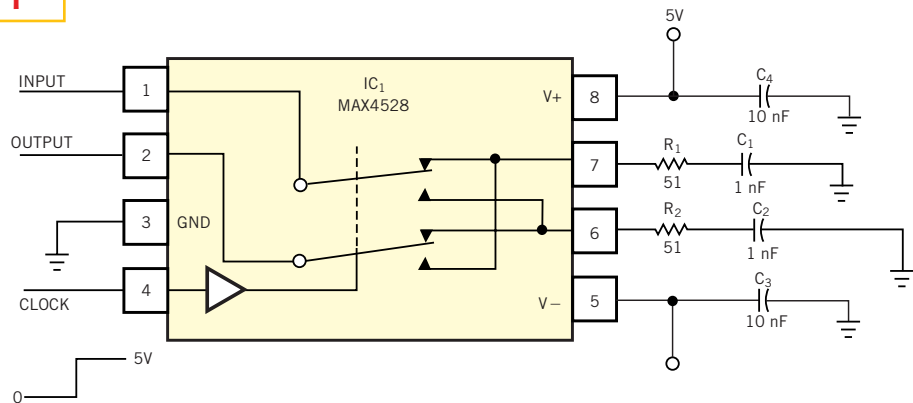

A simple phase-reversal switch uses two hold capacitors to implement a continuous-sampling sample/hold circuit.

Figure 2

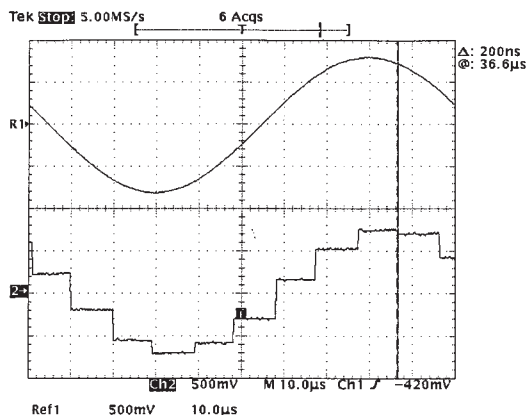

At a 100k-sample/sec sampling rate, the circuit in Figure 1 provides excellent hold accuracy.

Figure 3

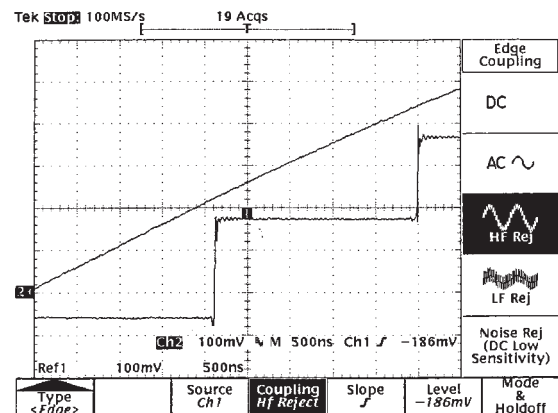

The S/H circuit in Figure 1 exhibits low ringing and overshoot characteristics when sampling at 400k samples/sec.