

POWER CONTROL

Winning

BIG



**BACK-TO-BASICS KNOWLEDGE CAN MAKE
AC AS EASY TO CONTROL AS DC.**

AS ITALIAN TIRE GIANT Pirelli's advertising reminds us, "Power is nothing without control." But if your application is automotive, consumer, or industrial, embedded control is often

worthless without power-handling ability. If you want to control dc power, your task is now easier than ever, with today's MOSFETs handling many amps at 600V or more with ever-decreasing conduction losses. At the low-voltage end, complementary die and packaging technologies recently allowed Philips to announce the first sub-1-m Ω device. Available devices include International Rectifier's 30V-rated IRF6618, which has a worst-case on-resistance of 3.4 m Ω from logic drive—easily good enough to handle 20A—in a surface-mount footprint that measures just 6.25 \times 5 mm. Elsewhere, competitors including Fairchild, Infineon, and Vishay all offer commodity devices that break the sub-10-m Ω barrier. At the high-voltage end, Infineon's CoolMOS technology reduces on-resistance to as little as 0.29 Ω in an 800V-rated device. And if you want smart-power switches with integrated protection and diagnostics, you're similarly spoiled for choice (**Reference 1**). Best of all, you can often implement a power driver simply by choosing a suitable component and connecting it directly to an output port.

But unless you're a career-level power engineer, ac power control has the time-served reputation of being tricky as well as potentially hazardous. As a result, many digital designers feel less confident when they suddenly need to interface embedded controllers to offline ac supplies. But in myriad applications, from white goods to light industrial control, dc power simply isn't an option; for one thing, without complex and expensive

synchronous-rectification *At a glance***64**
circuitry, the diode losses alone can be crippling. You then have to select switching devices that will withstand line power and the transients and overvoltages that accompany public-utility supplies; derive a logic-level power supply, preferably with the ability to work offline anywhere in the world without component changes; implement suitable interface circuitry, typically including an isolation barrier between your logic and the line-power outlet; and devise control methods that not only suit your application, but also minimize EMC issues. You may also suspect that these tasks tend to become progressively more complex as the voltage and current envelope widens. So, which

techniques are available to simplify your challenge, preferably to the point that any digital designer can approach offline ac control as confidently as familiar low-voltage dc rails?

APP NOTES PROVIDE RICH RESOURCE

Demystifying an unfamiliar discipline can sometimes be difficult. Although universities concentrate on exotic technologies, less glamorous topics, such as power control, often receive scant exposure. For example, the leading bookstore in the UK university city of Cambridge recently had just two power-control texts on its shelves—one of which is unreadable unless you enjoy complex math between each paragraph. Those of us who prefer the Babylonian conceptual approach to Greek formulaic abstraction are better off with semiconductor vendors' application information. Start with *Power Semiconductor Applications*, an essential and freely downloadable compendium from staff at Philips' power-semiconductor-applications lab.

Other invaluable resources include application notes from Fairchild, Teccor, and Vishay. Historically, industry consolidation has resulted in product lines and technologies from companies such as Motorola and Quality Technologies now being offered by Fairchild, where power semiconductors account for no less than 72% of revenue. Similarly, Vishay owns the assets to former lines from specialists such as General Semiconductors, as well as some ex-Siemens products. Crucially, the new owners have preserved years of application-note heritage and make them freely available. Armed with this information, you'll soon want to try some circuits for yourself (see sidebar "Discovery learning tests concepts" on the Web version of this article at www.edn.com).

Let's assume that you need to control a load of, say, 0.5 to 1 kW, which typifies many low-cost white-goods applications, such as heaters and small universal motor controllers. Together with voltage and current ratings, the control method deeply impacts your choice of power switch. For such applications, the traditional choices are phase-angle and cycle-by-cycle control. Until recently, designers often used phase-angle control to vary the amount of power delivered during every half-cycle. But, because phase-angle control inevitably results in high values of dV/dT as the switching point

AT A GLANCE

- ▶ Typical consumer and industrial applications mandate ac power.
- ▶ Vendors' application notes provide rich training resources.
- ▶ Don't necessarily dismiss electro-mechanical relays.

moves farther from the ac-line zero-crossing point, it's become ever less appropriate in environments that have strict emissions regulations, such as the European Union (**Figure 1**). If you strip a contemporary phase-angle-control domestic light dimmer, you'll find that the largest component is an inductor of about 1 to 2 mH that quashes noise that would otherwise couple back into the line supply. As a result, cycle-by-cycle control is typically today's preferred method, but you need to ensure conduction for equal numbers of whole positive and negative half-cycles to avoid dc imbalances that similarly induce power-line distortion. Notice that either method requires you to include a zero-crossing detector to synchronize your logic's switching commands. If power-line isolation isn't an issue, your detector can be as simple as a high-value resistor (say, 2.2 MΩ) between ac live and an input port.

You then need to select a switching device. If you're driving a load that's free of large inrush currents that can weld metallic contacts, the simplest option is an electromechanical relay. These low-cost but deeply unfashionable devices

provide high power capability in a compact package, as well as high breakdown and isolation characteristics, and they are supremely easy to drive. Such relays also have the attribute of virtually negligible conduction losses, especially if you can synchronize switching to zero line voltage and avoid destructive contact arcing and EMI generation; in practice, mechanically induced phenomena, such as contact bounce and variable contact, closure times over lifetime make this ideal difficult to achieve.

However, advances in materials technology enable vendors such as IMO, Omron, and Nais to produce relays with mechanical switching lifetimes of more than 10 million operations, which equates to switching once per minute for more than 15 years. The electrical lifetime depends heavily on the nature of the load, but don't dismiss relays out of hand if you have a low duty-cycle requirement for a finite lifetime. If you're keen to learn more, try a Web resource, such as Book-Finder.com, to locate a copy of Hans Sauer's now-out-of-print classic, *Modern Relay Technology* (**Reference 2**).

RELAYS PROVIDE CONTROL

Electromechanical switches naturally lead you to consider solid-state ac-relay equivalents from vendors such as Clare, Ixys, Crydom, Nais, and Omron. For low-current use up to several amps, these devices typically package an optocoupler with a pair of back-to-back MOSFETs (**Figure 2**). Although MOSFETs are intrinsically bidirectional, two are necessary to overcome the structure's parasitic

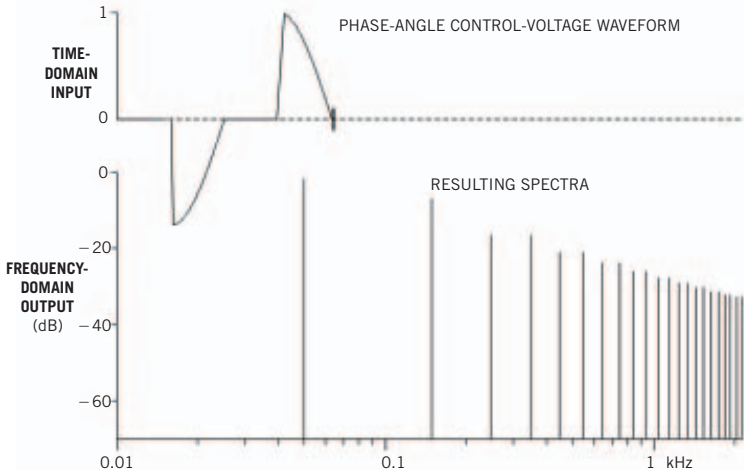

Figure 1 The high dV/dT values that characterize phase-angle control create power-line noise with appreciable energy to 10 kHz and beyond.

source-drain diode, which incurs cost and efficiency penalties. But compared with the electro-mechanical option, this approach adds the attribute of zero contact arcing, no contact bounce, and indefinite lifetime. Crucial design issues include a relatively limited range of component choices. The dissipation requirements limit current-handling ability to about 3A rms for pc-board-mount parts, which suitable heat sinking can extend to around 10A peak.

It's essential to consider blocking voltage ratings, above which the device may temporarily break down or catastrophically fail. Most designers prefer at least a factor of two between the peak voltage and the device's rating, or 650V dc for 230V-ac use. Most available devices have 600V-dc ratings that provide massive margins on 110V-ac supplies, but 800V better suit European use.

Available now for approximately \$6 (10,000), recent introductions include Clare's CPC1977J, whose data sheet states 4A peak continuously and 600V, with 25°C on-resistance figures of 0.57Ω typical and 1Ω maximum. According to field-application engineer Klaus Wiedorn, the specification is extremely conservative: "Internally, the CPC1977J uses a pair of 26A, 800V MOSFETs that give you lots of margin. The biggest application problem is getting the heat away from the package." A direct copper-bond ceramic substrate yields a thermal resistance of just 0.45°C/W from junction to ambient and provides isolation for the through-hole-mount plastic package, which measures about 20 mm sq by 5 mm deep. Conservative design demands a heat sink to support the device's 4A peak capability, which equates to about 2.8A rms. The solid package requires clip mounting, or you may consider a thermal interface material, such as Warth's KA150-2AC. Available in 300-mm-sq sheets or precut profiles, this electrically conductive aluminum-foil material has a layer of thermally conductive adhesive on each surface that adds the equivalent of 0.49°C/W thermal resistance to a TO-3 outline.

Using MOSFETs rather than triacs confers application benefits that include freedom from commutation failures due to high dV/dT and load dependencies; providing you correctly drive the CPC-1977J, it will faithfully replicate load-switching commands. But all optocou-

Figure 2

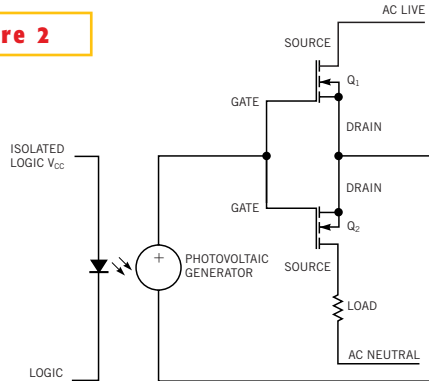

Back-to-back MOSFETs provide bidirectional control in solid-state ac relays, such as Clare's CPC1977J.

pler devices require adequate LED drive current over variations of temperature and time, especially to minimize switching-time variations. Expect turn-on times to be longer than turn-off, because the photovoltaic generator requires time to develop sufficient charge to fully enhance the MOSFET gates. At room temperature and given 10-mA drive current, the CPC1977J develops an enhancement voltage of about 7.5V and typically conducts within 7.5 msec; typical turn-off time is just 85 μsec. Apply 20 to 30 mA if you can afford the dissipation and want best performance over temperature, and also to compensate for the LED's half-life (typically 10 years at 25 mA and 75°C junction temperature, a point that's often neglected). Notice that some manufacturers describe LED drive-current values for a given switching condition as "maximum," when a more intuitive interpretation would be "minimum"; device dissipation sets the maximum value.

If off-the shelf devices don't suit your application, you might build your own MOSFET solid-state relay. The bugbear is always how best to drive the MOSFET gates, but devices such as Clare's FDA215 gate-driver chip hugely ease this approach. The eight-pin DIL or surface-mount device contains two photovoltaic generators that produce about 5.5V, sufficient to enhance an efficient 20A power MOSFET such as Infineon's 650V-rated SPx20N60C3. Again, expect a relatively lengthy turn-on as the photovoltaic generator's few microamps charge the power MOSFET's input capacitance. If turn-on is too slow, the MOSFETs dissipate power during the linear-conduction region before full enhancement; in some cases, this dissipation may limit

duty cycle. However, a slow turn-on inherently tends to quash switching transients as the relay begins to conduct. The FDA215 driver guarantees rapid turn-off by including an active off-time clamp that applies a low-value resistor across the common gate-drain junctions. This clamp is essential; without a means to hold the gates safely below their threshold voltage, sufficient current is likely to flow through the parasitic gate-drain capacitance to modulate the gates at line frequency. Depending on how far this leakage enhances the power devices, they may never turn off or turn on partially in the linear region—leading to power dissipation that's almost certain to precipitate device destruction.

TAME TRIACS FOR LOWEST COSTS

Triacs are the classic ac power-control device, but they suffer a fearsome and largely undeserved reputation for being difficult to understand and apply. Ignore this reputation; it's still hard to beat a triac for efficiency and low installed cost in most offline applications. Cost apart, advantages that triacs have over high-voltage MOSFETs include a relatively static conduction loss of around 1.4 to 1.8V. In contrast, a MOSFET's dissipation follows an I²R loss model that can cripple applications requiring more than a few amps. Monolithic triacs are a dual-polarity, five-layer derivative of the Schottky diode family of four-layer pnpn devices that include thyristors, also known as SCRs (silicon-controlled-rectifiers).

SCRs are unidirectional, three-terminal devices that you can think of as a pair of pnp/npn bipolar transistors (Figure 3). Assuming that the anode connects to a positive supply and the cathode to a load, two possibilities exist to turn on this SCR. First, apply gate current to turn on the npn device; alternatively, apply sufficient potential across the anode/cathode to break down the device. If adequate load current then flows, regenerative action causes both devices to conduct and remain on until either the gate current or the load current falls to zero. Thus, if the supply is an ac voltage, momentarily triggering the SCR at the start of each positive half-cycle ensures conduction throughout that half-cycle cycle; when the load current hits zero, the device turns off.

Conceptually and sometimes literally,

too, triacs are back-to-back SCRs that control both ac line half-cycles. Accordingly, you need to trigger triacs equally on positive and negative half-cycles to ensure symmetrical conduction. Conventional triacs trigger in four operational zones, or quadrants. Some “high-commutation” or “alternistor” parts omit Quadrant 4 to increase their resistance to false triggering when driving inductive loads. The quadrants refer to the polarity of the gate pulse relative to Main Terminal 1 (Figure 4). Due to device construction, a triac’s operational characteristics differ between quadrants, with best sensitivity typically occurring in quadrants 1 and 3. But for simplicity and because most ICs sink more current than they can source, designers tend to use quadrants 2 and 3 to apply a negative trigger pulse. As a result, semiconductor vendors offer devices that have equally good sensitivity in these areas, with some devices requiring a gate trigger current of as little as 5 mA that suits direct logic drive. This low value compares with a traditional triac that requires as much as 50 mA.

Don’t assume that more is necessarily best where triac specifications are concerned. Specifically, the high gate sensitivity that eases logic interfacing also confers a higher likelihood of false triggering by high dV/dT transients, such as inductive loads create. Therefore, use the least sensitive device that you can accommodate. Similarly, don’t needlessly overspecify current ratings. To minimize gate-power dissipation, you typically trigger triacs once around each ac zero-crossing point, when the device latches on, providing that there’s sufficient latching and holding current. Be sure to check these minimum values, both of which vary with triggering quadrant but typically lie within 10 to 150 mA. It’s therefore conceivable that a high-power device may not latch on when driving light loads. But according to Bob Krause, applications manager for Fairchild’s optoelectronic and power products, the key parameter is static dV/dT resistance—where more is unquestionably better. Krause reckons that false triggering with inductive loads is the number-one application headache: “The back EMF [electromagnetic force] attempts to recommutate the triac, and if it’s successful, the triac stays on permanently as it’s continually retriggered.”

Figure 3

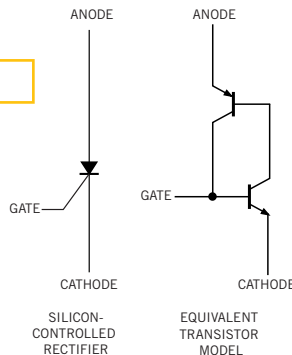

A silicon-controlled rectifier follows a two-transistor operational model.

For sinusoidal waveforms, dV/dT is about 8.89 times the rms volt/hertz product, or close to 100 kV/sec for 230V, 50-Hz supplies. But you have to guard against line-borne transients, such as those induced by lightning strikes as well as high dV/dT waveforms that your load might create. The EN61000-4-x series of standards specifies European-protection requirements for line-borne phenomena (Reference 3), but there’s no substitute for real measurements to quantify the back EMF from loads such as motors. Designers invariably add MOVs (metal-oxide varistors) from vendors such as Epcos and Littelfuse across the power device to provide transient protection. Techniques to help mitigate dV/dT -induced false triggering include adding RC-snubber networks in the triac’s gate-trigger circuit (Reference 5). Alternatively, look for three-quadrant-operation triacs optimized for high dV/dT applications that can obviate the need for snubbers. A sensitive-gate, three-quadrant device, such as STMicroelectronics’ BTA08-600TW offers 5-mA gate-drive capability with 20V/ μ sec dV/dT resistance; in its non-sensitive 50-mA guise (BW suffix), this same device boasts 1000V/ μ sec dV/dT resistance.

Consider a couple of potential triac gate-driver configurations. For the high-side switch action that designers typically prefer, MT2 connects to ac live and MT1 to the supply side of a neutral-referred load. But it’s equally possible to connect MT1 to neutral and MT2 to the return side of a live-referred load, creating a low-side switch. Reasons for using a low-side configuration include the relative ease of biasing the gate-drive voltage when using a nonisolated supply; that

is, where logic V_{CC} connects directly to neutral. Such supplies are popular in low-current, lowest cost applications that typically derive logic power from a capacitive dropper. You can also rearrange connections so that V_{CC} connects to ac live, and logic ground floats relative to neutral, which enables negative-going trigger pulses directly from a microcontroller’s I/O pin (Figure 5). Because current flow in the capacitor is 90° out-of-phase with voltage, it dissipates virtually no power. The resistor provides surge suppression and typically drops only about 10V, or 200 mW. Notice that the diode/zener arrangement yields full rectification that halves holdup-capacitor requirements. Even so, practical component values limit this circuit’s usefulness to about 20 mA, which means that you must minimize power consumption, including gate-trigger current. Techniques include applying a short burst of trigger pulses to ensure that the triac latches and minimizing dc power drain (Reference 6). Other disadvantages include the requirement for different capacitor values for US/European use and the fact that representative-value X1- or X2-rated safety capacitors are bulky, with typical 470-nF to 1- μ F parts requiring 27.5-mm lead pitch.

Thanks to dedicated ICs, such as Power Integrations’ LinkSwitch series, it’s now easy to build an offline-switch-mode power supply that provides an isolated low-current dc rail. The bill of materials for a 3W design can cost approximately \$4.50 and confer advantages, including universal input-voltage tolerance. Traditionally, your biggest problem with such switchers lies with magnetics design, but you can now purchase transformers for Power Integrations products online from Indian magnetics specialists Hical. In quantities of 1000 or more, Hical’s SIL6011 costs approximately just \$0.47 to enable a 42-kHz switcher built around Power Integrations’ LNK500 LinkSwitch chip. Comprehensive design notes helpfully describe input-filter requirements that guarantee European EMC conformance. Sample designs suggest using an optoisolator in the feedback loop to vastly improve no-load to full-load regulation, but a simple zener works just fine for low currents and is several times cheaper. Other vendors that offer offline supply chips include Supertex, whose SR036/

037 eliminates transformer couplings at the expense of providing no galvanic isolation.

OPTOTRIACS SIMPLIFY CIRCUITS

Using an isolated logic rail poses the problem of referring gate-drive current to the line supply. You could connect V_{CC} to ac neutral and drive the triac's gate low with respect to this point to create a low-side switch. But to retain isolation and create a high-side

switch, consider optoisolators. In particular, vendors such as Fairchild, Isocom, Sharp, Texas Instruments, Toshiba, and Vishay of-

fer a class of low-current optotriacs that target use as trigger devices for higher current triacs. Approximately costing as little as \$0.24, two variants are possible: so-called random-phase devices, and zero-crossing-detector versions. Random-phase devices trigger in the same way as normal triacs and are subject to identical design considerations, including static dV/dT resistance. Although it's

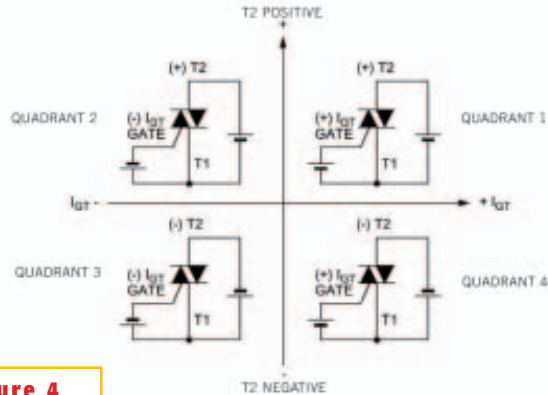

Figure 4

Conventional triacs can trigger in four quadrants, in which the gate and T2 polarities reference T1 (courtesy Fairchild).

possible to connect an optotriac directly to a power triac, it's more common to include some form of snubber to improve resistance to transients. But, as with power triacs, this snubber can introduce unwanted phase shifts between control and output-power switching points. Also notice that static dV/dT resistance typically declines with increasing temperature for random-phase optotriacs—from, say,

10V/ μ sec at room temperature to less than 2V/ μ sec at 100°C.

Zero-crossing-detector devices, such as Fairchild's MOC-3163-M, include a bidirectional threshold detector that holds off triggering the main triac if line voltage exceeds 12 to 20V. This feature vastly simplifies zero-voltage switching, because you can now drive the LED as you wish and leave line synchronization to the device. Devices are available with forward-current requirements of 5 mA and less, enabling direct logic connection. Because the LED forward

voltage is typically about 1.2V, operation from 3V logic is easy. Notice that, in its on state, the optotriac's driver output switches only momentarily to inject sufficient current to trigger the main triac. Once the main triac triggers, the voltage across the driver collapses to around 1.5V, and the optotriac's holding current is insufficient to maintain conduction. This process repeats on every half-cycle

as long as you apply LED forward current, so the optotriac automatically regulates the main triac's gate current. This action also commutates the main triac within the optimal 1 and 3 quadrants.

According to Fairchild's Krause, integral zero-crossing detectors also vastly increase the optotriac's static dV/dT resistance—to a minimum of $1000V/\mu\text{sec}$ for the company's MOC3163-M, which offers 5-mA LED-drive sensitivity. Further, the rating doesn't degrade significantly with increasing temperature. Fairchild's zero-crossing detector basically consists of a pair of high-voltage BiCMOS FETs, but Krause notes that similar part numbers from other vendors may have wider windows around zero due to alternative construction methods. For example, Toshiba's data sheet specifies a 50V maximum for its TLP306x series. He advises that Fairchild is working on parts to compete with Vishay's IL410 optotriac, which currently boasts the industry's highest dV/dT rating at $10\text{ kV}/\mu\text{sec}$, and expects these parts to be available this

You can reach Contributing Editor David Marsh at formcett@btinternet.com.

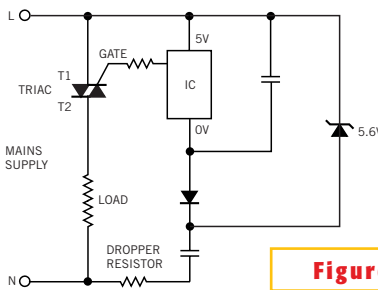

Figure 5

Capacitive offline droppers suit lowest cost applications but demand careful design to minimize power consumption (courtesy Philips).

year. Expect to pay around \$0.85 (1000) for the premium-grade MOC3163-M in six-pin DIPs. Unusually for this device class, Fairchild also offer random-phase optotriacs in four-pin, mini-flatpack, surface-mount packages; this small form factor precludes adding the zero-detection silicon. The best-spec FODM3053 has a 5-mA drive-current requirement and blocks 600V for about \$0.45 (1000).

Originally designed by Sie-

mens/Infineon and acquired by Vishay when Infineon quit the optoelectronics business, the IL410 comprises two back-to-back SCRs that are inherently less susceptible to high dV/dT than triacs. This technique also appears in some high-commutation power triacs from vendors such as Teccor. The IL410 also adds a

MOSFET clamp circuit that triggers above a dV/dT threshold and holds its SCR predriver off, preventing trigger current from flowing. These precautions obviate the need for snubber circuits, even in electrically noisy environments, such as industrial-motor controls. The 600V-rated IL410 is available now in a six-pin DIP for around \$1.82 (1000); the 800V IL4108 version costs around \$2 (1000).□

You can find a list of manufacturers and the article's references in the Web version of this article at www.edn.com.

TALK TO US

Post comments via TalkBack at the online version of this article at www.edn.com.

DISCOVERY LEARNING TESTS CONCEPTS

Because there's no substitute for first-hand experience, it's always prudent—and lots of fun—to try a few circuit ideas for real. You can design a board to test alternative concepts for, say, approximately \$364 to \$485, including prototype pc-board-origination charges. You may minimize origination charges by using an online service, such as Newbury Electronics' Pcbtrain (www.pcbtrain.com) or Beta Layout's Pcb-Pool (www.pcbpool.com). You upload your Gerber files, and your job becomes part of a batch, allowing the manufacturer to extend economies of scale to one-off and low-volume purchases.

Designed using the newly released Version 3 of the Pulsonix suite that now includes features such as star-ground support, the board in **Figure A** is a double-



Figure A Ensure that your test board includes safety features, such as fuses, indicators, and easily accessible test points.

sided plated-through-hole design that measures 160×130 mm. It costs about \$236 using Newbury's five-day service option. Unfortunately, it's almost always impossible to avoid leaded components in ac power applications. Philip King, Newbury's sales director, advises that you maximize the surface-mount component for volume manufacture: "Most jobs have a leaded element, and the cost of loading the leaded parts is two to four times the cost of loading surface-mount parts."

But before you start to design,

consider safety and the working practices that you'll need to make risk-free measurements. Remember that your safety and the safety of others is exclusively *your* responsibility, so ensure that you take every reasonable step to safeguard life and property. At the prototype pc-board level, such precautions include adding fuses, neon indicators, and easily accessible test points to your board; you'll be so glad you did!

Environmentally, now is not a good time to be earthed, so replace earthy antistatic floor coverings with a rubber-insulated wooden platform. Ensure that any antistatic bench accessories include high-value series resistors—especially if you're using a wrist strap. Use safety isolating transformers and residual current breakers to minimize electric-shock hazards. Notice that the 110V-ac site transformers that contractors use are centre-tapped to safety ground, thus minimizing shock hazard and permitting residual current-breaker operation. By contrast, variacs are not isolated but a useful addition to an isolation transformer for the moment when you first apply power to a circuit.

Making safe measurements also demands isolation between the instrument and safety ground. This is straightforward for multimeters, because virtually any withstand line voltages. But ensure that all test leads are intact, appropriately rated, and, preferably, fused, too. Mains-powered scopes are almost invariably earthy, so you need a differential probe that decouples your measurement from the instrument's chassis. Vendors include Agilent, Chauvin Arnoux (brand name Metrix), Pico Technology, Sefram (brand name Elditest), and Tektronix; catalogue distributors include RS Components.

For nonintrusive current measurements in ac and dc circuits, see LEM's

range of current probes, such as the PR50, which offers 3 and 50A capabilities at maximum frequencies of 50 MHz. Use an infrared noncontact thermometer, such as Raytek's Ranger series, to monitor components, and remember that components can—and occasionally do—explode, so always wear safety glasses.

Our test board evaluates a capacitive-dropper offline supply and an isolated supply that's built around a Power Integrations LinkSwitch chip and a Hical transformer. Both of these circuits worked the first time. Amazingly, measurements show that the LinkSwitch starts to work from less than 15V ac and continues up to at least 275V ac, the highest available test level. Jumpers then allow connecting three alternative output devices—a Clare CPC1997J solid-state relay; an STMicroelectronics BTA-08600TW triac; and an Infineon SPA20N60C3 power MOSFET that switches raw dc from a Diotec GB125K rectifier. Each power switch mounts to a 5.6°C/W heat sink. Control comes from Motorola's 68HC908QT4 microcontroller programmed using the company's Metrowerks CodeWarrior interface. The test load is an array of water-cooled, 50W power resistors, but incandescent bulbs are another way to dispose of considerable

power in a small space.

Gratifyingly, measurement results reasonably accurately confirm expectations. First taking the dc approach, a load of just 2A rms caused the MOSFET's surface temperature to rise by 12°C, but the uncooled rectifier's surface temperature rose some 74 to 97°C. Given that the diode loss-per-leg specification is 1.05V and the junction-to-ambient thermal resistance is 15°C/W, this result slightly exceeds expectations and is uncomfortably hot for conservative design. It's easy to add a heat sink that allows the rectifier to handle currents of as much as 25A, but you're simply moving heat-dissipation problems from one component to another. By comparison, the CPC1977J rose about 33°C at 2A rms, but applying 3.3A drove the device into a temporary failure mode with a case temperature in excess of 138°C. This result graphically illustrates the I²R loss model that MOSFETs incur. With a case-temperature rise of 33°C at 3.3A rms and a saturation voltage of 1.25V, the winner in cost, design, and energy efficiency turns out to be an old-fashioned triac; here, the key enabling technology comes from Fairchild's MOC3061-M zero-crossing-detector optotriac, which simplifies control with clean switching (**Figure B**).

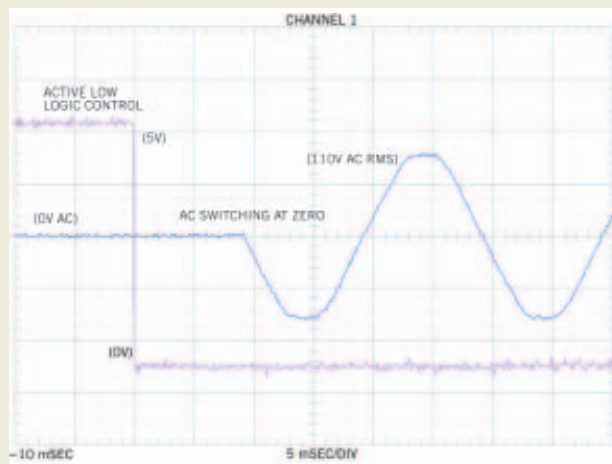

Figure B

Fairchild's MOC3061-M zero-crossing-detector optotriac simplifies control and produces clean switching.

FOR MORE INFORMATION...

For more information on products such as those discussed in this article, contact any of the following manufacturers directly, and please let them know you read about their products in *EDN Europe*.

Agilent

www.agilent.com

Chauvin Arnoux (Metrix)

www.chauvin-arnoux.com

Clare

www.clare.com

Crydom

www.crydom.com

Diotec Semiconductor

www.diotec.com

Epcos

www.epcos.com

Fairchild Semiconductor

www.fairchild.com

Hical Magnetics

www.hical.com

IMO

www.imopc.com

Infineon Technologies

www.infineon.com

International Rectifier

www.irf.com

Isocom

www.isocom.com

Ixys

www.ixys.com

LEM

www.lem.com

Littelfuse

www.littelfuse.com

Motorola Semiconductor

www.mot-sps.com

Nais (Matsushita)

www.naisrelay.com

Omron

www.omron.com

Philips Semiconductor

www.semiconductors.philips.com

Pico Technology

www.picotech.com

Power Integrations

www.powerint.com

Pulsonix

www.pulsonix.com

Raytek

www.raytek.com

RS Components

<http://rswww.com>

Sefram (Elditest)

www.sefram.fr

Sharp Microelectronics

www.sharpsma.com

STMicroelectronics

www.st.com

Supertex

www.supertex.com

Teccor

www.teccor.com

Tektronix

www.tektronix.com

Texas Instruments

www.ti.com

Toshiba Semiconductor

www.semicon.toshiba.co.jp

Vishay

www.vishay.com

Warth

www.warth.co.uk