

coverstory *By Bill Schweber, Executive Editor*

PROGRAMMABLE ANALOG ICs: DESIGNER'S DELIGHT OR DILEMMA?

ANALOG ICs THAT YOU CONFIGURE FOR YOUR TOPOLOGY OFFER FLEXIBILITY AND VERSATILITY,
BUT YOU NEED TO CONSIDER AVAILABLE PERFORMANCE AND LONG-TERM FACTORS AS WELL.



At a glance74

What's the middle ground?.....74

For more information84

ANALOG-CIRCUIT DESIGNS have fundamentally different architectures from those of processor, FPGA, and PLD designs. Once you implement the circuit topology and parameters, the circuit's signal-processing function is relatively

fixed. Sure, some functional blocks exist, such as filters, in which you can digitally adjust cutoff frequency, roll-off, and other factors by varying the clock (for switched-capacitor designs) or adjusting circuit factors via DACs, but these examples are the exceptions. Most designs are fixed in their functions and nearly fixed in their performance.

This fixed-forever aspect is not necessarily a bad thing; in fact, it's often a good thing, because the analog-signal processing path's performance is thus stable and

one fewer variable in your system. But analog designers must sometimes suffer a form of programmability envy, looking at the ease with which the design can change, update, or adapt its functions by reprogramming an FPGA or a PLD or by changing software, often without touching the pc board or any of its components.

Analog designers do have the programmability option, however. Several vendors now offer analog ICs that give you the ability to establish or modify



their topologies or performance parameters as a one-time production step or once your system is in the field. This programmability offers you the virtues of configurability and even reconfigurability or the ability to adapt your circuit performance to match the dynamics of your applications. The analog ICs let you use the same basic part in different designs and provide some protection for the secrets of your analog design, which competitors might otherwise trace or assess by looking at the active and passive components and their interconnections.

You should carefully consider the implications and limitations of these programmable analog components and the implications of using somewhat-unique analog components in your system.

AT A GLANCE

- ▶ Programmable analog ICs serve as design alternatives for some applications when you need to vary your circuit's parameters or its underlying topology.
- ▶ Programmable analog ICs offer lower envelopes of performance than available standard analog ICs.
- ▶ You need to carefully consider performance capabilities and sole-source-products limitations.

As with so many technical terms, the words "programmable" and "programmability" have various meanings, de-

pending on the user and on which components are the subject of your discussion. A programmable digital component can be a processor that executes either fixed or varying code (the program). It can be a programmable device, in which the circuit interconnections are mask-programmed at the factory or field-programmed by the OEM, such as with a gate array or logic device. It also could mean that the user defines some functional parameters, such as bit rate, and stores them in internal registers.

With analog programmability, some of these definitions do not apply. For example, you don't execute sequential code instructions. When using a programmable analog circuit, you can interconnect analog cells in a desired pattern at the fac-

Figure 1

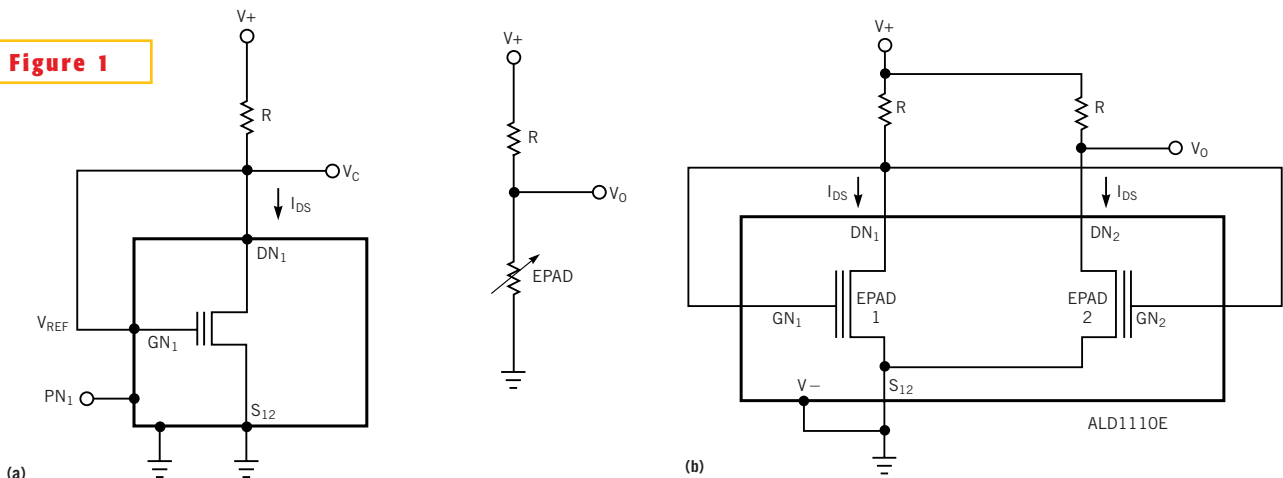

The EPAD from Advanced Linear Devices lets you program the threshold of a MOSFET. The equivalent circuit shows its function as a variable resistor (a); for bidirectional control, you connect two devices back to back (b).

WHAT'S THE MIDDLE GROUND?

Some common applications, such as filtering, allow you to choose ICs that implement fixed topology and signal path, and you can select key parameters, for example, cutoff frequency or roll-off. These single-purpose, limited-flexibility ICs from vendors such as Linear Technology Corp minimize your design time and risk and provide the benefits of more programmable analog ICs (Reference A).

Other vendors marry analog-signal-processing functions with on-chip EEPROM, letting you

store configuration and calibration data. For example, Maxim's Max1459 sensor signal conditioner and 4- to 20-mA loop-interface IC has an internal EEPROM that holds correction coefficients for offset, offset temperature, full-span output, full-span output temperature, and linearity. Proper programming of this device yields a sensor whose output-signal accuracy rates better than 1% and is stable, even though the sensor itself is not. The company markets other signal-conditioning interface ICs

that embed an EEPROM for corrective purposes as well.

Finally, mask-programmed arrays are an alternative. For example, Micrel Semiconductor offers the MPD8021 semicustom power IC, which combines low-voltage analog and digital circuits with high-voltage CMOS power drivers. The device comprises bipolar pnp and npn transistors, CMOS gates, zener and Schottky diodes, resistors, and capacitors that you can interconnect. Using it, you can get a working prototype in six weeks—much shorter

than the turnaround for a new design. However, because the MPD8021 functions as a mask-programmed device, you can't reprogram it if you have a problem or your requirements change. However, the IC's cost is similar to that of a design using discrete components, even in low volumes.

REFERENCE

A. Schweber, Bill, "Analog filters: even more essential in the digitized world," *EDN*, April 24, 1997, pg 42.

tory or OEM, or you can even reprogram the cells in the field. Alternatively, the circuit may have a fixed topology with major parameters, such as filter bandwidth or roll-off, that you can set and change according to your application. However, in such cases, the signal-processing path and basic function remain unchanged; only the parameters vary.

The desire and ability to program analog circuits are not new. Early analog computers had patch cords and plug boards that let engineers use basic modules in arrangements and swap passive component subsections to meet their needs. In the IC-based mixed-signal world, engineers have long used DACs to digitally set analog-circuit parameters, especially for filters, and they even used analog switches to reconfigure and reroute the analog-signal-processing path. These reconfigurable and reroutable architectures require careful architectural planning, pc design, and error-budget analysis.

When you need programmability, it may seem that digital is really the only way to go. However, even if you are biased toward the processor and executable-code worlds, you may choose analog for several reasons. For example, almost every signal-processing application requires filters; even digital filters need analog Nyquist-frequency filters to avoid aliasing in the sampling process. Low-level signals usually need amplification to

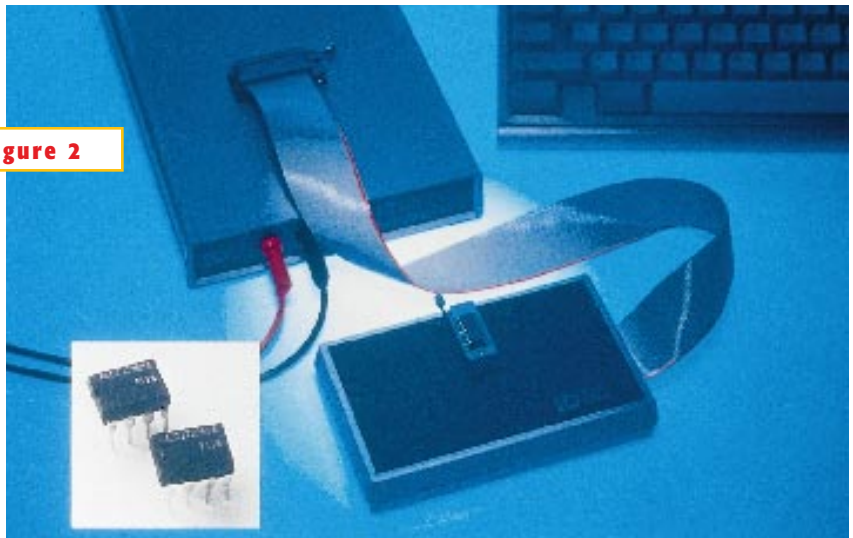

Figure 2

Programming the EPAD requires a vendor-supplied programming unit.

make them compatible with the signal range of converters and to achieve maximum SNR and dynamic range. Even if you can filter or shape your signal using all-digital techniques, the analog approach often is less costly and power-hungry. Think about a peak detector: It's one or two op amps and a few diodes in the analog world, and it's a filter, an A/D converter, and a processor if you implement it digitally.

Don't confuse programmable analog ICs with analog ASICs and mask-programmed arrays. Some vendors offer a library of analog cells that they model and interconnect to meet customers' applica-

tions. For years, both vendors and customers believed that by using the cell library, they could relatively easily configure an analog IC tailored to their needs. ("I'll take an op-amp cell, a comparator cell, and a multiplier cell, thank you.")

However, your need for high-performance analog designs makes it harder for designers to configure and produce these high-performance ICs because of the existence of so many subtle interactions, thermal issues, and layout- and process-dependent factors. Many OEMs of analog circuits use cell libraries as their starting points for a standard product's design, but they also have to apply their experience to make essential adjustments to the final interconnected-cell design to make an IC that meets the desired goals.

VENDOR OFFERINGS HAVE RANGE

Differences in architectures and performance emerge when you compare basic analog offerings, such as op amps and converters, from different sources. However, you can usually resolve these differences and come up with a meaningful apples-to-apples comparison beginning with basic specifications, such as bandwidth, settling time, linearity errors, and other first-order measures of performance and then considering more subtle but also critical secondary measures.

With programmable analog ICs, however, each vendor offers products with underlying philosophies. Some are basic analog functions, such as an amplifier; others incorporate more functions and

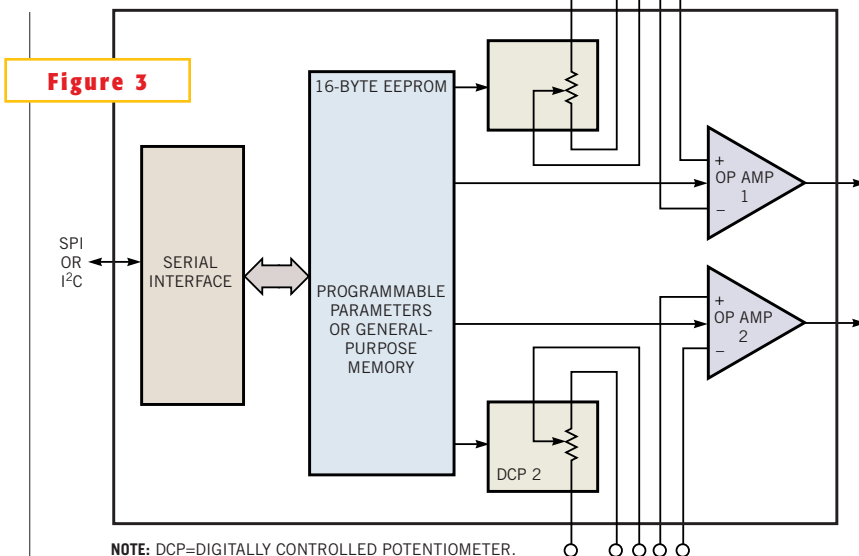

NOTE: DCP=DIGITALLY CONTROLLED POTENTIOMETER.

Figure 3

Xicor's X9430 dual op amp lets you program key parameters in nonvolatile memory and apply the unused memory locations to other purposes.

operate as analog-signal-processing subsystems in themselves. You have to look carefully at your application requirements and then see which product type, if any, translates effectively into your situation. You may find a close fit, a moderate fit, or no reasonable fit at all. You may need an uncommitted array that you can configure to an almost arbitrary signal path, for example, or you may just need a filter with some topology and parameter choices.

Start by looking at a basic function: the MOSFET transistor. Advanced Linear Devices offers a series of electrically programmable analog devices (EPADs) that allow you to adjust the threshold voltage and the on-resistance both before and after insertion into the final circuit (**Figure 1a**). This EPAD works as an electronically controlled trimming potentiometer in transducer preamps and sensor-signal-conditioning paths. You can even envi-

ronmentally seal the device if your application needs protection or place it in an unreachable location yet still access this parameter. Once set, the offset voltage saves internally even if you remove the power. With the dual ALD1108E and quad ALD1110E devices, which cost approximately 50 cents in large volumes, you can program bias levels of 0.1 μA to 3 mA and voltages of 1 to 3V in 0.1 V steps. (Note that increasing threshold voltage corresponds to decreasing drain current.)

From an underlying physics perspective, externally injecting electrical charges changes the EPAD parameters into a floating-gate substrate; these injected charges increase the threshold level. If your design needs bidirectional control, you arrange two EPADs back-to-back because this programming is a monotonic function (**Figure 1b**). Also, you cannot reprogram the EPAD an infinite number of times. A

typical EPAD circuit allows 20 to 50 reprogramming cycles, which is sufficient for many applications, such as matching a preamplifier to a sensor's characteristics or factory-calibration cycles.

The virtues of using EPADs to replace a trimming potentiometer are that EPADs have no moving parts, are environmentally rugged, and have higher resolution than the typical one-part-in-2000 specification of a 10-turn mechanical unit. Further, you can seal EPADs and adjust them via software. However, you have to also consider factors such as EPADs' limited retrimming cycles, application challenges, and limited selection of values.

EPADs include more than basic MOSFETs. The vendor offers op amps, such as the ALD1722E and the micropower ALD1726E, which allow you to set the initial offset voltage, V_{OS} . By setting this voltage, you can reduce or eliminate V_{OS}

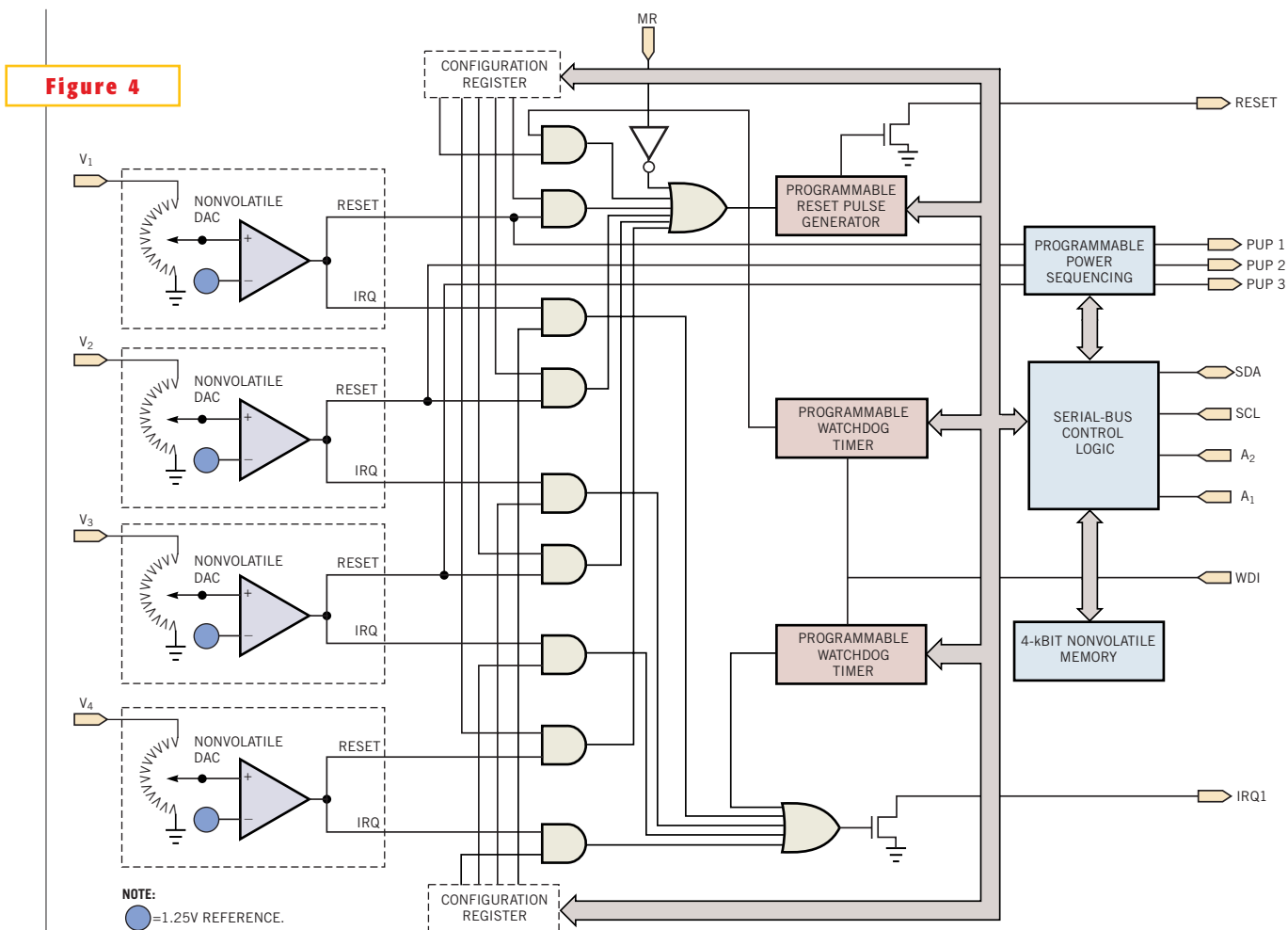

Figure 4

The SMS44 voltage-supervisory circuit from Summit Microelectronics lets you program basic voltage thresholds, combinational arrangements, reset-pulse width, and output configuration.

errors due to bias conditions and contributions due to power-supply rejection ratio, common-mode rejection ratio, and V_{OS} temperature-coefficient errors. The initial input V_{OS} of the ALD1726E, when the company ships it, is 50 μ V, and you can adjust this voltage to as much as ± 10 mV. The \$1 op amp operates from supplies as low as 2V, has typical input current of less than 0.01 pA, and has a 200-kHz bandwidth and 0.17V/ μ sec slew rate.

To program an EPAD, you use the \$499 E100 programming unit (Figure 2). This unit, which operates with a Windows-based PC, implements a programming algorithm with the goal of minimizing programming time by speeding threshold-voltage settling. Simultaneously, the unit minimizes its overshoot beyond the target value.

The programmer has templates for the various EPADs, and you use it with a \$199 personality module that adapts it to specific EPAD families.

Another programmable-op-amp vendor, Xicor Inc, offers a line of digitally controlled electronic potentiometers (Reference 1). The company's X9430 dual op amp lets you set gain, offset, and power level to match your application's needs (Figure 3). By adjusting the offsets, you can calibrate the signal channel to minimize the effect of offset drift that occurs with temperature or aging, for example.

The dual op amp houses a nonvolatile EEPROM, which stores your set parameters; in addition to the 4 bytes that the op amp requires, the EEPROM also has 12 bytes that you can use for other, non-op-amp-related data storage. You program the device through an SPI (X9430) or I²C serial interface for the X9438. You can also independently access the associated digital potentiometers that control the op amp offsets in this \$3.95 (10,000) IC.

Moving up the complexity ladder, Summit Microelectronics combines analog circuitry with nonvolatile memory to create ICs for which either the company or, in some cases, an end user can trim analog functions, such as setting a threshold level for a supervisory circuit. These devices offer you the advantage of tailoring one part as necessary to the vagaries

Figure 5

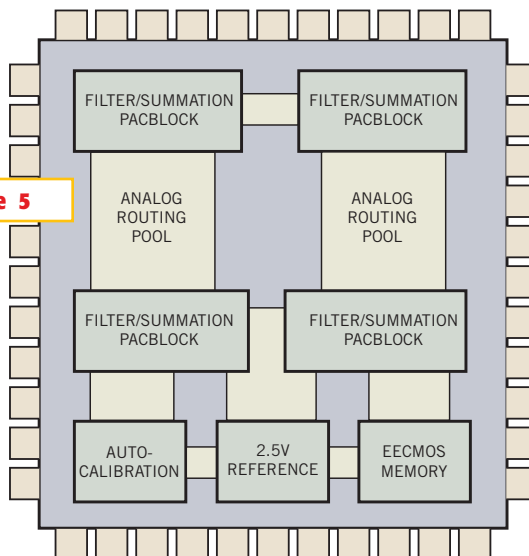

The ispPAC10 from Lattice Semiconductor gets you started in programmable topology with four filter and amplifier blocks plus an analog routing pool for resource allocation.

of the IC or circuit that you are monitoring.

For example, Summit Microelectronics' \$7.58 (1000) SMS24 programmable supervisory IC lets you set two levels of configuration via a two-wire serial interface or a system programmer unit. First, you can vary the pin and internal block functions for reset output polarity, watchdog-timer reset, write-protect optimization, and manual reset, among others. Second, you can establish the parameters for voltage thresholds and timing periods. The reset voltage threshold ranges from 2.15 to 4.75V.

Similarly, the Summit hot-swap controllers, such as the SMH4042, let you

Figure 6



You program the ispPAC10 series with a design kit that includes PC-based software, two IC samples, and an evaluation board.

change voltage trip points as needed. The basic function that hot-swap controllers need—monitoring host-supplied voltages and back-end voltage levels and then turning on or off the power MOSFETs that gate the power supply rails that feed the card's logic—is conceptually simple. However, in practice, platform-to-platform variations of as high as 50 mV on each supply exist. This IC, which performs host- and card-voltage supervision, includes a 1V reference output to ease bus-precharge design, a programmable ramp rate for reliable power-up and -down, and CompactPCI handshakes and pin detection.

Extending this concept of programmable parameters but with a fixed topology, Summit developed the SMS44 quad voltage monitor (Figure 4). You can set each monitor to independently watch voltages of 0.9 to 6V in 20-mV steps, set the time-out period for the watchdog timer, establish logical combinations of the monitored voltages to generate reset and interrupt outputs, and set the reset-pulse width.

The SMD1108 IC adds an eight-channel, 10-bit A/D converter plus additional monitored channels, along with more nonvolatile memory. In this device, you can also set high and low limits on the converter channels, and if any input passes a threshold, the IC generates an interrupt or alert.

For designs requiring configurable circuits, Lattice Semiconductor offers a family of analog blocks along with the design tools. The starting member of the family, the less-than-\$7 (1000) ispPAC10 includes four filter-summation blocks that you interconnect using an analog routing pool (Figure 5). Each block contains two instrumentation amplifiers and an output amplifier. The device has a maximum programmable gain of ± 20 , a gain range of zero to 160,000, and programmable filter response, and it targets functions such as summation and integration. The IC also has a 2.5V reference and nonvolatile memory. The similar ispPAC20 adds an 8-bit D/A converter and a pair of differential comparators.

You design for your signal-processing application using a PC-based design kit

and software, and you can use available macros for common functions, such as continuous-time biquad and ladder filters and filters of various orders (Figure 6). These filters can operate at bandwidth as great as 100 kHz. You design your circuit using the available functional blocks, select components and values, define interconnections, and then run the simulation to verify that the circuit yields your desired result.

Once you finish the simulation, you program the IC either as a stand-alone component or as an in-circuit component. The internal nonvolatile memory stores the settings you choose. These devices provide a 650-kHz available bandwidth, -88 -dB THD at 10 kHz, and 100-dB dynamic range.

For more complex configurability, Lattice recently introduced the ispPAC80, a 5V programmable device for filtering with a variety of topologies, including Butterworth, Chebyshev, Legendre, elliptical, Gaussian, and linear phase. This continuous-time, fifth-order-filter device operates at bandwidth as great as 500 kHz with frequency-setting accuracy as much as 3.5% of target frequency and includes all necessary resistors and capacitors and a programmable-gain amplifier. All internal circuitry is differential from input through output, and this device combines 300- μ V offset with precision CMOS amplifiers and -90 -dB THD at 1-kHz ac performance.

You can preset two filter configurations into the ispPAC80 and then use one command, which you send via a JTAG interface or an SPI, to direct the IC to flip between them. Using this feature lets your application go from a wideband, fast-settling signal-acquisition mode to a narrowband signal-extraction mode or adapt to signal situations. The \$149 Windows-based design software lets you select from a library of filters by calling for desired performance targets and constraints or by identifying the topology you prefer; you can also define your own circuits. The design software then selects the appropriate configuration and component values, provides dc and ac simulation, and documents the design.

For flexibility and configurability, Zetex offers the Total Reconfigurable Analog Circuit (TRAC) product family (Figure 7). This BiCMOS IC emulates the historical predecessor of single-function analog modules interconnected by patch

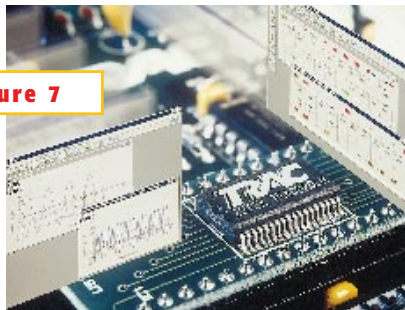

The TRAC family from Zetex lets you assemble and define the elementary functions of its analog blocks, perform simulation, and then load the configuration into internal memory.

boards. The TRAC is the analog counterpart to a digital FPGA. Zetex's dc to 1-MHz, \$11.75 (1000) TRAC020LH device comprises 20 analog processing cells, which you interconnect to form the signal-processing function.

You define the function, or operand, of each cell: open circuit, short circuit, add, negate, log, antilog, rectifier, differentiate, integrate, and amplify or attenuate. (Think back to high-school math: You use the log and antilog functions, along with addition and subtraction, to achieve multiplication and division.) The TRAC, using all on-chip components, implements most of these operand functions, but some require user-supplied external resistors and capacitors. The TRAC IC stores your functions in internal registers. You develop a block diagram of your signal-processing functions and then implement it with the TRAC cells (Figures 8a and b).

To develop your TRAC-signal-processing path, you use a Windows-based PC and the vendor's development kit. The \$460 kit contains four of the 20-cell TRAC devices and EEPROM on an emulation board, design software, and documentation. With this software, you capture your design by selecting the desired cell function from a toolbar and dropping it onto the desired cell, adding interconnections, and selecting internal components and internal and external connections. Next, you simulate performance to see what the configured circuit will do. Finally, you download the acceptable configuration data to the TRAC-device registers from your PC using a parallel cable. If you have higher product volumes and are comfortable with the TRAC implementation, you can migrate to a fixed-function, lower

cost version with a metal-mask interconnect layer defining the performance in the high-frequency parameters.

STEP BACK AND WEIGH CHOICES

Programmable analog ICs offer some distinct advantages in flexibility, customization, and inventory and purchasing when you use the same unprogrammed device in multiple parts of your design or across products. Carefully consider some points before you take the plunge.

First, the issue of achievable analog performance emerges. With the thousands of analog components available from analog-IC vendors, you can find parts that excel in one group of primary and secondary factors—ac performance, dc performance, noise, power consumption, and cost—or some combination of these factors to match your needs. Programmable analog ICs are less outstanding in any one performance parameter or set than these fixed-performance conventional analog components. The programmable devices instead balance various performance factors, but their balance may not fit your application. They tend to target the low to middle frequencies, which require a fairly good but not outstanding performance.

Second, by using a programmable analog component, you veer away from a fundamental reality of analog ICs: Alternative sources exist for many basic components, such as op amps and converters. Vendors offer some proprietary or leading-edge components that excel in one or more performance attributes, but you can usually find a close or acceptable pin-compatible alternative if your vendor has a delivery problem, even if you have to accept some compromise or trade-off.

Because many systems use proprietary parts for which there are no alternative devices in some portions of their design, most designers and project managers try to minimize the use of these sole-sourced items. Designers then confine the use of these devices to aspects in which the unique component gives a competitive edge. For other aspects of the design, usually within the analog-signal-processing chain or the power-supply function, you should have insurance in case a problem with a vendor or the vendor's product arises. You are tied to the vendor of the programmable analog IC; you can't al-

ways anticipate whether the vendor will change its product lines. Motorola heavily promoted its MPAA-series programmable-analog-array family through application notes, product releases, and design support, but the company then dropped the product line as part of a strategic reassessment and the On Semiconductor spin-off.

When you buy a nonprogrammable component, you allow the vendor to assume the burden of testing, trimming, and packaging for that component, and you accept the vendor's assurance that the part performs to the specifications that the data sheet lists. In effect, you trade your potential component flexibility for minimal component uncertainty, although your final circuit has some design uncertainties. When a programmable component performs differently from how you expect, however, it may be harder to determine whether the problem is the result of the part's failure to meet specifications or whether you are misapplying it.

You also need to be comfortable with the tools and development system the programmable-IC vendor offers because you'll need the software and programming units for your design. Again, this situation differs from most analog-design efforts, which use vendor-supplied data sheets and component models but apply them with supported simulation tools, such as Spice, or EDA tools from various sources. Further, these other design efforts require no programming systems.

Figure 8

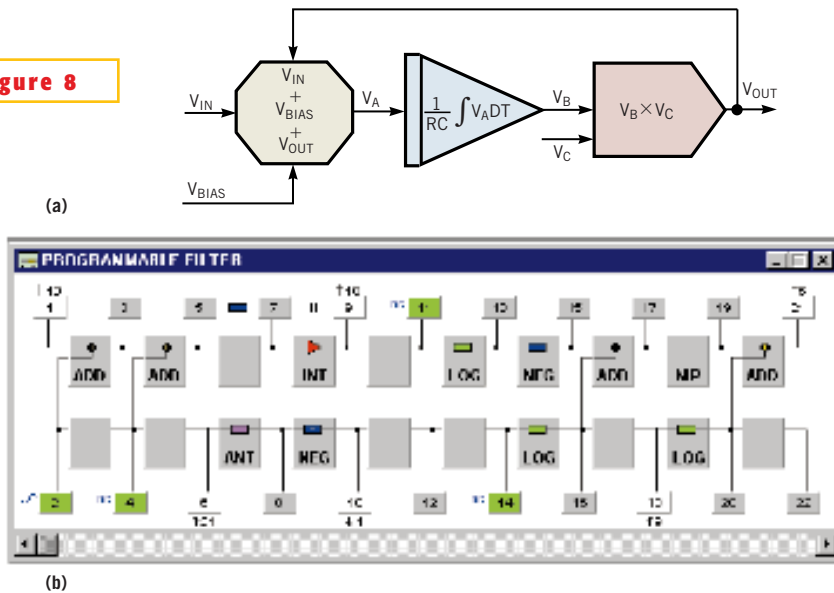

With the TRAC approach for a programmable filter, you develop an analog-signal-processing flow at the system level (a) and then implement it by defining the mathematical operations and inter-connection of function blocks (b).

If your application can operate with the lower performance levels or has flexible or hard-to-define requirements, programmable analog components may be appropriate. Depending on the device you select, you can vary component parameters. You can also change your circuit's performance and even its topology on the fly, reduce inventory and unique items on your bill of materials, and develop an adaptive design whereby your system processor can change the attributes of the analog-signal-processing

chain to match situations. You may even get some protection for your design secrets using these components.

These components are inherently unique, restricting you to a range of common applications. You'll need proprietary design and simulation tools, and you'll lose the huge choice of vendors and components that most analog designs enjoy. Also, consider application support, the wealth of available design notes for standard analog components, and time to completed design.

If your design needs flexibility, using standard, nonprogrammable components along with the ability to mechanically or electronically program some functions may be a good alternative (see sidebar "What's the middle ground?"). □

You can reach Executive Editor Bill Schweber at 1-617-558-4484, fax 1-617-558-4470, e-mail bill.schweber@cahners.com.



FOR MORE INFORMATION...

For more information on products such as those discussed in this article, circle the appropriate numbers on the Information Retrieval Service card or use EDN's InfoAccess service. When you contact any of the following manufacturers directly, please let them know you read about their products in EDN.

Advanced Linear Devices

1-408-747-1155
www.aldinc.com
Circle No. 333

Xicor Inc

1-408-432-8888
www.xicor.com
Circle No. 336

Maxim Integrated Products

www.maxim-ic.com
Micrel Semiconductor
www.micrel.com

Lattice Semiconductor

1-503-268-8000
www.latticesemi.com
Circle No. 334

Zetex

+44-0-161-622-4567
www.zetex.com
Circle No. 337

Summit Microelectronics

www.summitmicro.com
1-408-378-6461
Circle No. 335

OTHER COMPANIES MENTIONED IN THIS ARTICLE

Linear Technology Corp
www.linear-tech.com

SUPER CIRCLE NUMBER

For more information on the products available from all of the vendors listed in this box, circle one number on the reader service card.

Circle No. 338

ACKNOWLEDGMENTS

Thanks to John P Skurla at Advanced Linear Devices Inc, Andy Robin at Lattice Semiconductor Corp, Richard Palm at Summit Microelectronics Inc, and Alan Buxton of Zetex Inc.

REFERENCE

1. Schweber, Bill, "Gain control goes silicon," EDN, May 11, 1995, pg 113.