

IN MANY FREQUENCY-CONTROL APPLICATIONS, INEXPENSIVE SAW DEVICES CAN REPLACE BULKY LC FILTERS AND QUARTZ CRYSTALS.



SAW filters from AVX come in hermetically sealed and surface-mount versions.

SAW filters and resonators provide cheap and effective frequency control

At a glance.....104
For more information.....104

IN THE WORLD OF ELECTRONICS, ceramics are wondrous and versatile materials. They serve as insulators, as substrates for deposited conductors and resistors, and as a medium for multilayer capacitors. In some ceramic materials, the piezoelectric effect gives rise to useful applications, such as buzzers and other audible alarms. One manifestation of the piezoelectric effect is the SAW (surface-

acoustic-wave) phenomenon, in which signals travel acoustically in the ceramic material. The term “acoustic” refers to the mechanism of propagation; even a dog can’t hear the frequencies that SAW

devices handle. SAW filters are inexpensive and compact alternatives to bulky LC (inductance-capacitance) filters; SAW resonators can replace quartz crystals in many frequency-control applications.

In its literature for SAW filters, AVX Corp reveals construction details for a typical SAW filter (**Figure 1**). The device is an electroacoustic bandpass filter that operates via delay paths that conduct (passband) and cancel (stopband) frequencies. An RF signal applied to the electrodes generates surface waves in the piezoelectric ceramic material. The amplitude and phase of the surface waves are functions of the distance between and overlap of the electrodes. The input to the filter is through the interdigitated-electrode transducer, which generates a SAW in the piezoelectric substrate. This wave travels to the output interdigitated-electrode transducer and

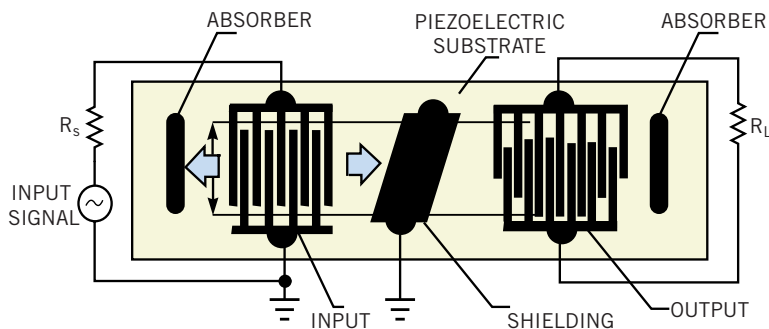

Figure 1

A SAW device works by “acoustic” propagation through a ceramic medium.

produces a voltage output. Damping material (absorbers) direct and prevent scattering of the wave. SAW filters exhibit higher insertion loss than do LC filters, so you need to provide more gain in a given circuit to compensate for the loss. The prime feature of a SAW filter is its flat passband characteristic (low ripple), coupled with a constant group delay (low-phase distortion). SAW filters find wide usage in TV, CATV, VCR, satellite-receiver, and cordless-telephone applications.

SAW FILTERS BEAT OUT OTHER TYPES

Another type of filter is the “dielectric-resonator” filter. This type also uses ceramic but does not use the piezoelectric surface-wave mechanism of a SAW filter. LC filters are available in multilayer, monolithic-chip form. Dielectric-res-

AT A GLANCE

- ▷ SAW filters are smaller and more selective than LC filters.
- ▷ You must provide some gain to compensate for SAW filters’ insertion loss.
- ▷ SAW resonators can replace LC elements and quartz crystals.

hibit virtually no amplitude ripple in the passband. Also note that the insertion loss of a SAW filter is greater than that of the other two types. Again, this loss is of little import in most applications; you need supply only a little more gain to make up for the insertion loss.

Because of their small size, low cost, and good frequency characteristics, SAW filters are popular in

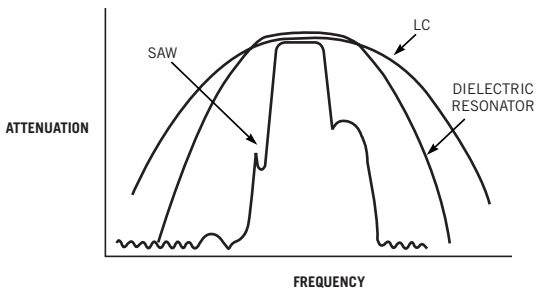

Figure 2

the entire alphabet soup of wireless applications, such as SONET (synchronous optical network), GSM (global system for mobile communications), and DECT (digital European cordless telephone). A typical cellular system might use as many as four SAW filters: a receive, transmit, local-oscillator, and IF (intermediate-frequency) filter (Figure 3). Murata’s

A SAW bandpass filter has much steeper skirts than an LC or a dielectric-resonator filter.

SAF-Series SAW filters, targeting wireless applications, cover the frequency range of 83.16 (IF) to 1960 (RF) MHz. The RF

onator, SAW, and LC filters differ primarily in insertion loss, attenuation, and size (Reference 1). Table 1 compares the attributes of the three RF-filter types. For example, multilayer, monolithic techniques can shrink an LC filter to match the size of a SAW filter, but, for a given size, an LC filter offers a worse attenuation figure. SAW filters are the only types that rate “best” in two attributes (Table 1). In the data sheet for its SAF Series of SAW filters, Murata gives a graphical comparison of the frequency responses of dielectric-resonator, SAW, and LC filters (Figure 2). Frequency-roll-off characteristics for SAW filters are much sharper than those of the other two types of filters. The roll-off characteristics of a SAW filter exhibit some anomalies, but they are of little consequence in most applications. Note that all three types ex-

filters, as usual, have 50Ω input and output impedances; the IF filters have varying terminal impedances. The family covers 18 wireless standards. Murata also offers a range of SAW filters for TV/VCR and set-top-box applications. The band-pass filters cover the sound and picture IF in the TV systems. Other companies producing SAW filters for RF and IF use include AVX, CTS, Micro Networks, Panasonic, Sawtek, Vectron, and Toyocom.

Murata is currently developing its next-generation, surface-mount microwave SAW filters. The company’s existing SAW filters measure 3.8×3.8 and 3×3 mm; the new products will measure 2.5×2 mm. The standard pinout for unbalanced (single-ended) SAW filters will change. The new unbalanced SAW filters will have only four pins instead of the current six.

Sawtek lays claim to the industry’s smallest cellular-RF SAW filters. The 2×2×0.9-mm devices use flip-chip packaging. The initial 2×2-mm products operate in the cellular receiving and transmitting bands for CDMA (code-division-multiple-access), TDMA (time-division-multiple-access), and AMPS (advanced-mobile-phone-system) handsets. Future flip-chip products will cover GSM, PCS (personal-communication-system), and 3G (third-generation) systems.

SAW RESONATORS REPLACE LC AND QUARTZ

Ceramic (including SAW) resonators can replace bulky LC elements and expensive crystals in many frequency-con-

FOR MORE INFORMATION...

For more information on products such as those discussed in this article, go to our information-request page at www.rscanners.ims.ca/ednmag/. When you contact any of the following manufacturers directly, please let them know you read about their products in EDN.

AVX Corp
www.avxcorp.com
 Enter No. 315

Panasonic Corp
www.panasonic.com
 Enter No. 318

Vectron International
www.vectron.com
 Enter No. 321

Micro Networks Corp
www.micronetworks.com
 Enter No. 316

Sawtek Inc
www.sawtek.com
 Enter No. 319

Murata Electronics
www.murata.com
 Enter No. 317

Toyocom USA
www.toyocom.com
 Enter No. 320

SUPER INFO NUMBER
 For more information on the products available from all of the vendors listed in this box, enter No. 322 at www.rscanners.ims.ca/ednmag/.

trol applications. (Reference 2). Ceramic resonators offer:

- frequency stability between that of LC and that of crystal oscillators;
- half the size of LC or crystal elements, low weight, low cost; and
- immunity of frequency to external circuits or supply.

In the Colpitts and Hartley oscillators (Figure 4a), the oscillation frequencies are the same as the resonant frequencies of the inductor-capacitor tank circuits. In the ceramic-resonator oscillator (Figure 4b), a ceramic resonator replaces the inductor, taking advantage of the fact that the resonator becomes inductive between its resonant and its antiresonant frequencies. The circuit uses a CMOS inverter instead of a transistor as a gain element. Ceramic resonators find wide usage in the gamut of electronic devices that use frequencies, from TVs to sewing machines to toys.

Murata's SAR Series of SAW resonators cover a resonant-frequency range of 308.4 to 479.45 MHz. They target remote keyless-entry systems, remote garage-door openers, and remote-start-up transmitters. AVX's PAR Series of SAW resonators cover 304.45 to 433.92 MHz; the series targets Japanese, US, and European keyless-entry systems. Panasonic's EFOH family covers 100 to 490 MHz; these devices also aim at keyless-entry systems, garage-door openers, security systems, and local oscillators.

In fiber-optic data-link and telecommunications applications, NRZ (nonreturn-to-zero) data streams can easily be-

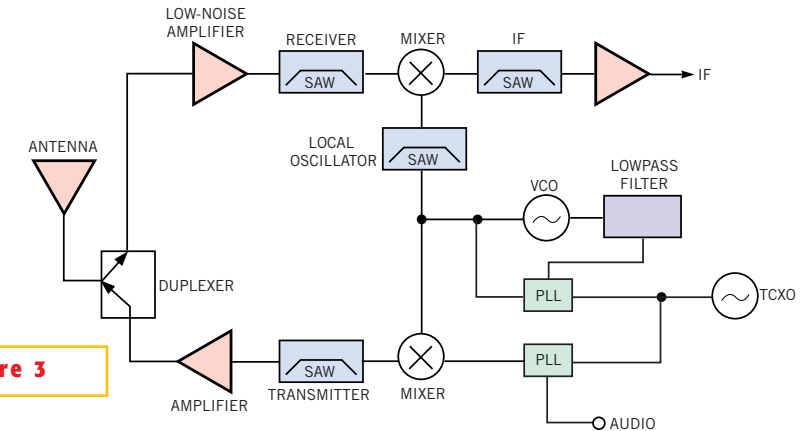

Figure 3

A typical cellular application uses as many as four SAW bandpass filters.

come corrupted. SAW filters can help with the timing recovery. Vectron's is a SAW-based timing-recovery unit that uses a high-speed bipolar ASIC and a SAW filter in a 28-lead surface-mount ceramic package. To extract a clock signal from the input data, the device first passes the data through a prefilter and a frequency-doubler stage. This operation generates precision narrowband SAW filter centered at the clock frequency substantially suppresses jitter by rejecting other frequencies. The device then accurately aligns the extracted clock with the incoming-data signal at the input of a decision circuit, which then retimes the data. The TRU600 is available with standard SONET/SDH (synchronous-digital-hierarchy)/ATM frequencies of 155.52, 311.04, and 622.08 MHz. Additional frequencies for other standards, ranging from 124.416 to 278.528 MHz, are also available.

For customers who prefer to build their own timing-recovery circuits on their SONET/SDH/ATM boards, Vectron offers SAW filters to perform the clock-extraction function. The filters have center frequencies of 155.52, 622.08, and 2488.32 MHz. Vectron also offers a SAW-based VCO (voltage-controlled oscillator). The VCO600 uses an ASIC

with an on-chip phase shifter for frequency pulling and a SAW-based delay line. The device is available with the standard SONET/SDH/ATM frequencies. Typical applications are data retiming and synchronization as part of a PLL, as well as frequency synthesis and frequency translation. The VCO has an absolute

TABLE 1—RELATIVE MERITS OF FILTER TYPES

Attribute	Dielectric resonator	SAW	LC multilayer
Insertion loss	Best	Good	Good
Attenuation	Good	Best	Good
Volume	Fair	Best	Good
Design flexibility	Good	Fair	Best

pull range of ± 50 ppm. Sawtek is also profiting from its SAW-filter expertise to develop VCOs for the wireless-communications market. The VCOs will target multipoint distribution systems, as well as multiband software base stations and digital radios.

For bandpass filtering and frequency generation, SAW filters and resonators are often the least expensive components to use. Moreover, they also exhibit several technical and space-saving advantages over their LC and quartz counterparts. They are available in miniature surface-mount form, an important consideration for handheld devices. □

REFERENCES

1. "SAW-based frequency control product applications," Application Note, Vectron International.
2. "Introduction to ceramic resonators," Application Note, Murata Electronics.

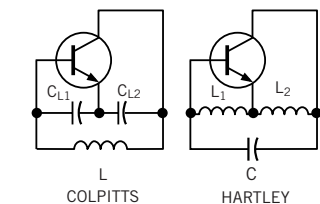

(a)

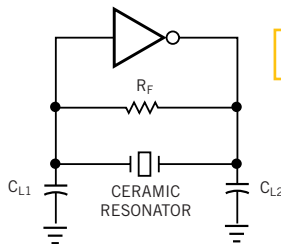

(b)

A ceramic resonator (b) takes the place of the inductors in the LC oscillators (a).

Figure 4

their own timing-recovery circuits on their SONET/SDH/ATM boards, Vectron offers SAW filters to perform the clock-extraction function. The filters have center frequencies of 155.52, 622.08, and 2488.32 MHz. Vectron also offers a SAW-based VCO (voltage-controlled oscillator). The VCO600 uses an ASIC

You can reach Senior Technical Editor Bill Travis at 1-617-558-4471, fax 1-617-558-4470, e-mail b.travis@cahners.com.