

**DESIGNING A SWITCHING AMPLIFIER IS ONE THING;
DESIGNING ONE THAT SOUNDS GREAT IS ANOTHER.**

Sound advice for Class D amplifiers

CLASS D SWITCHING AMPLIFIERS bring undeniable benefits to audio applications in circuit efficiency, size, and cost improvements. But meeting the needs of today's consumer electronics—such as audio-video receivers that demand more than 100W of output power with less than 0.05% distortion and more than 100-dB dynamic range—can be challenging using Class D amplification. These amplifiers also have to “sound good,” a requirement that's far more subjective than simply measuring and meeting target specifications for distortion noise and dynamic range. Analysis of a well-designed Class D amplifier yields a number of practical design guidelines that can help you to meet all of these goals.

The key to a Class D amplifier's efficiency improvements over Class AB amplifiers is the use of a switching output stage rather than a conventional linear one. In a traditional analog-audio environment, a typical system requires a modulator to convert incoming signals to a PWM (pulse-width-modulation) bit stream and an output-driver stage and filter to convert the PWM back to analog power levels that suit the load. Contemporary digital-audio environments, such as CD and DVD, directly provide serial data, which can be processed in the digital domain before interfacing with the output-driver stage (Figure 1). This requirement leads to a new class of amplifier ICs—digital modulators—which feature controls, such as volume and equalization, and key processing circuits, such as noise shaping

and digital filtering, to enable signal reconstruction.

Modulator bit-resolution, noise-shaper order, and the relationship between PWM- and master-clock frequencies all considerably influence audio quality. Another key consideration is the architecture of the on-chip digital filters, which help to maintain the detail of the recovered audio signal. The output driver also requires careful design to preserve pulse shape, minimize distortion, and ensure the best audio performance. Protection circuits are essential for safe operation, especially at high output-power levels, but they, too, must not compromise sound quality. The effects of power-supply and reference-clock quality on overall system performance are also important factors to consider.

MODULATOR

Digital filters are fundamental to the modulator architecture. Coefficients that relate to the tap length of the filter repeatedly multiply data samples. The effect of this process can degrade audio performance. Consider current audio standards, such as DVD-A, which can feature a maximum bit resolution of 24 bits; conventional digital amplifiers have internal datapaths of only 24 bits. In the multiplication process, this situation leads to the truncation of lower levels within the input signal to keep the larger signals within the available bit size. The result is a loss of low-level signal accuracy, degrading the listener's ability to hear background detail and hampering depth perception. A modulator with higher bit res-

Figure 1

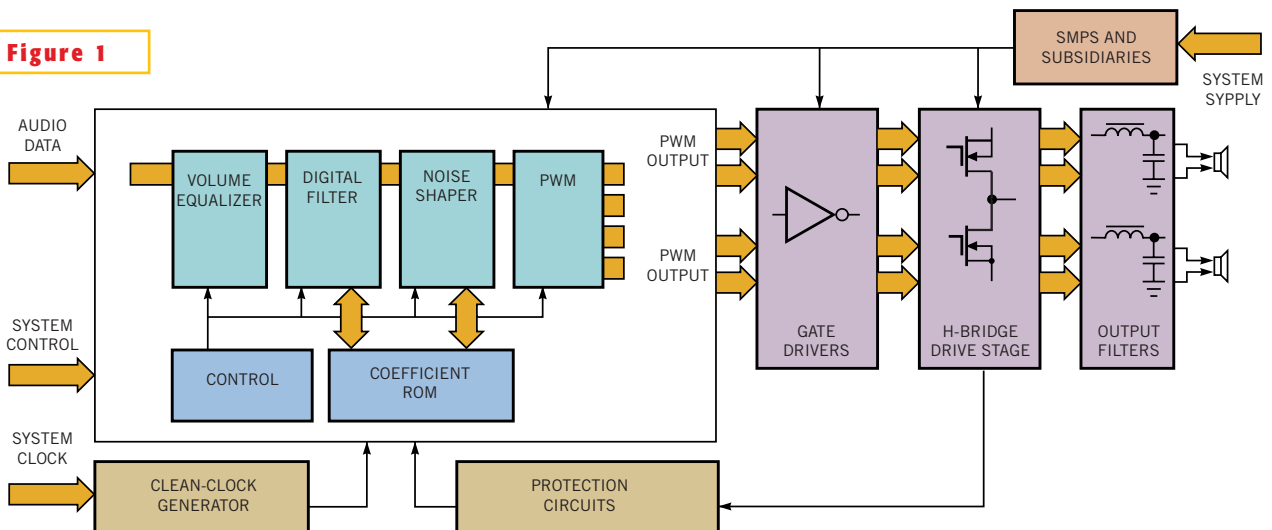

A typical digital-input Class D amplifier converts audio signals to a high-power PWM filtered output before delivery to the load.

olution produces less truncation, so audio quality improves accordingly. In practice, a 32-bit modulator offers a perceptible advantage, but it's debatable whether finer resolution further improves sound quality.

FILTERING, TAP LENGTHS, AND TRANSIENTS

The FIR (finite-impulse-response) interpolation filter is a key element within any digital amplifier. Typically, these filters employ oversampling techniques to shift the aliasing images of the input signal beyond the audio spectrum. Such images exist at the harmonics of the data's sampling frequency. The implementation of the filter can introduce various compromises that you must consider when selecting a modulator to minimize their impact on audio performance.

General practice removes images at as high as eight times the sampling frequency—as high as 352.8 kHz for 44.1-kHz recordings, for example. Analog filters can remove images beyond this limit. Some modulators oversample as many as 48 times, rather than the conventional eight. This higher order filtering ensures that very-high-frequency images neither generate intermodulation distortion nor degrade the jitter performance of noise shapers.

Higher sampling rates can improve sound quality, as comparisons between DVD-A's 96-kHz recordings and CD's 44.1-kHz offerings demonstrate. However, compromises between silicon area and speed can limit the capabilities of a digital modulator's on-chip filters. An ideal filter would have a brick-wall cutoff characteristic that would require an infinite tap length, which is impractical. Generally, modulators with long taps are preferable; 256 taps represent one of today's longer implementations.

Even so, many systems with high oversampling levels and long taps include filter-performance compromises that create signal-reproduction inaccuracies. One explanation for this sound-quality degradation is the loss of transient timing information within the audio signal. Zetex, for instance, claims that its proprietary ZTA-filter algorithm preserves such timing information, which is critical to the sonic performance of its amplifiers. Successfully combining high oversampling levels with long filter tap and preserving transient information can

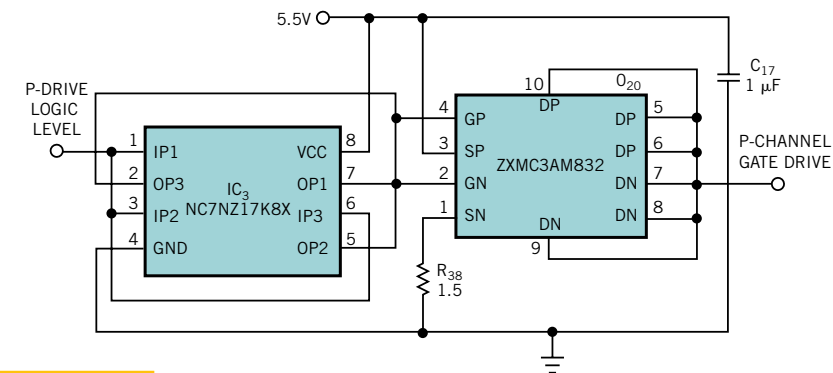
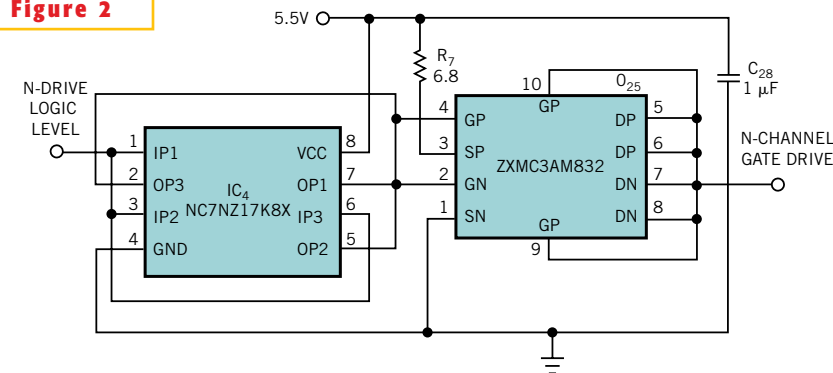

Figure 2



Tiny logic devices and complementary FETs provide high-speed drive for bridge-FET gates.

achieve smoother, more focused sound quality, with a deep and precise sound stage and tight bass definition.

NOISE SHAPER, PWMs, AND RESOLUTION

A Class D amplifier that employs digital processing has an apparent disadvantage compared with its analog equivalent. Although digital PWM produces a quantized output signal, analog-PWM architectures offer theoretically infinite pulse-width resolution. To compensate, digital amplifiers employ noise shaping to reduce errors that the finite resolution causes. Noise shaping is conceptually an averaging process, but the process in reality is recursive. Because the PWM frequency is much higher than the highest frequency audio content, it's easy to correct errors in any given pulse width with a subsequent pulse.

Many digital modulators employ a PWM noise-shaping system that switches at 384 kHz with a 98-MHz master clock for a 48-kHz sample rate. Other topologies can improve audio performance, such as lowering noise at higher frequencies. For example, the Zetex ZXCW-8100 uses a 1-MHz PWM switching frequency; a 33-MHz master clock; and a fourth-order noise shaper, which yields a resolution of 33-to-1, or about 5 bits. The 384-kHz system's resolution is

around 255-to-1, or about 8 bits. The 384-kHz system appears to have a resolution advantage of 255/33, or around 18 dB. But if you consider the correction its noise shaper gives, the 1-MHz architecture holds the advantage. Because noise shapers correct at nominally 6 dB per order per octave, a fourth-order noise shaper corrects at around 24 dB/octave. If the two noise-shaper architectures were the same, the 1-MHz system's advantage would be $1M/0.384M$, or 2.6—equivalent to 1.38 octaves.

In practice, the 1-MHz device runs its noise shaper at twice the PWM frequency by converting on both edges of the clock, so its advantage is 2.38 octaves, or 57 dB; overall, the 1-MHz noise shaper's advantage becomes 57 – 18 dB, or 39 dB.

Because 384-kHz systems use higher order noise shapers, such as seventh-order, you might expect each additional order to provide another 6-dB improvement. This situation rarely occurs, however. Even if you achieve an 18-dB improvement from the 384-kHz system's three additional orders of noise shaper, the 1-MHz architecture still wins.

After the modulator, the PWM output requires amplification to drive a speaker, almost invariably using power MOSFETs in a bridge configuration. Gate-driver circuits must provide level-shifting

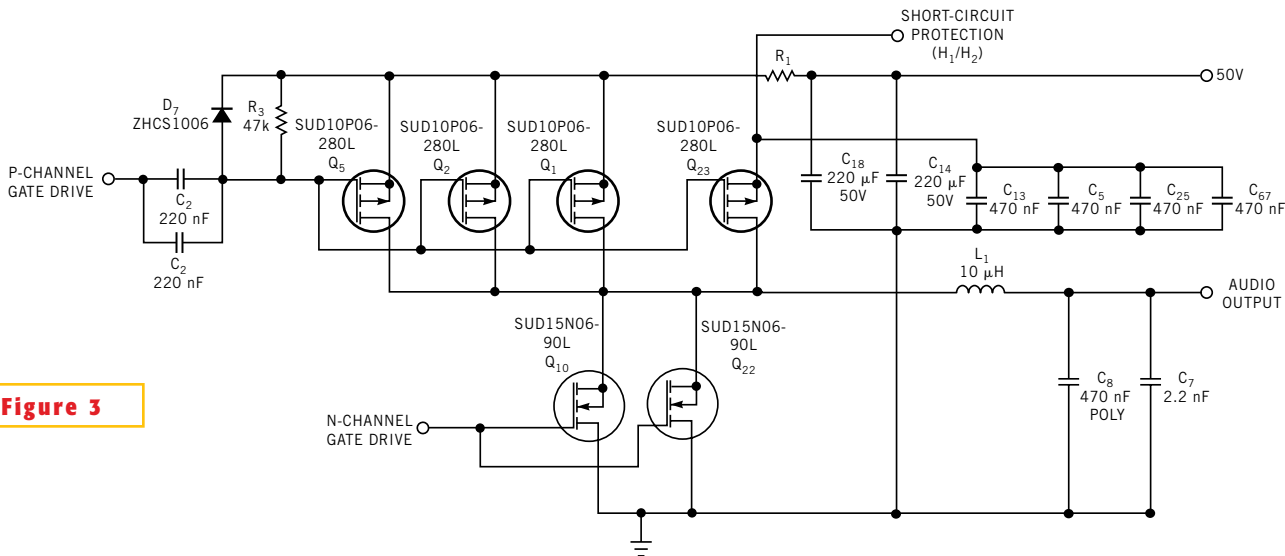
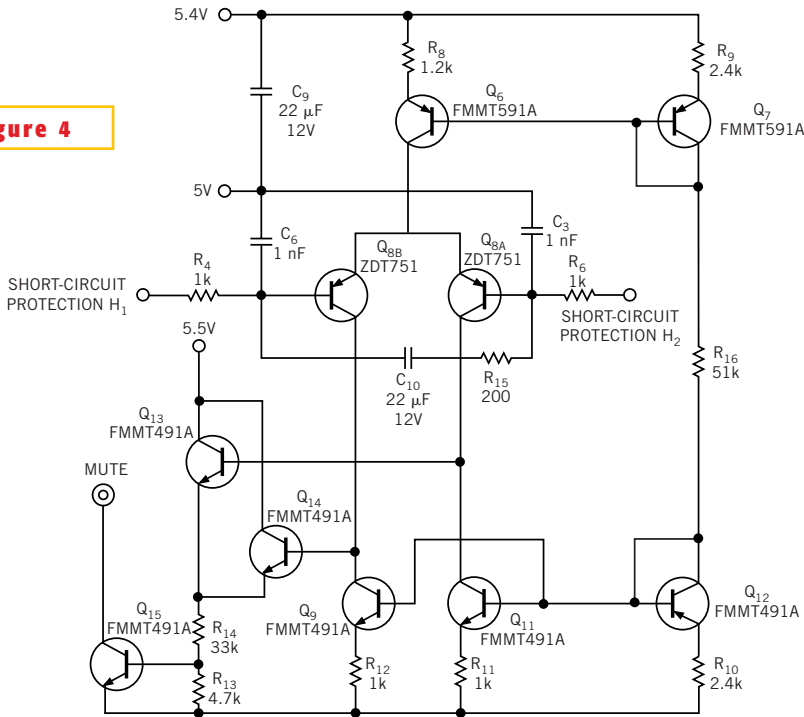

Figure 3

Complementary FETs in a BTL configuration show one-half of the BTL output bridge.

and current drive but without distorting pulse shape (Figure 2). These circuits use tiny NC7NZ17 logic devices with complementary ZXMC3AM832 FETs to provide a high-current, high-speed drive to a bridge in a 1-MHz PWM system. Speed is critical to maintaining the pulse integrity that preserves dynamic range and minimizes distortion. A 33-MHz master clock and 1-MHz PWM clock require a 30-nsec pulse resolution; typically, the driver must switch in 8 nsec and support about 4A peak current. Because a significant trade-off exists between distortion and dissipation in the bridge, it's also essential to control the shoot-through current that flows in the fractional time that both top and bottom bridge FETs conduct. Here, resistors in the gate-drive buffers limit shoot-through by controlling the on-times of the N- and P-channel FETs. P-channel control focuses more on minimizing ringing, but slowing the N channel's on-time balances its switching point to match the slower P channel's response.

Figure 4



This bridge-sense circuit protects an amplifier that can deliver 150W into 8Ω.

OUTPUT-STAGE BRIDGE DESIGN

Because Class D amplifiers typically use an open-loop topology, there's no benefit from feedback. Audio performance can then be susceptible to matching errors in the bridge. A single-ended output is simple and offers the possibility of bridging outputs to deliver more power but lacks inherent cancellation. A full H-bridge optimizes cancellation to provide the best performance and delivers maximum power from any given supply voltage.

In designing a bridge, you can choose complementary or all-N-channel devices. Complementary bridges are simpler to drive, because all-N-channel versions require bootstrap circuits to enhance the high-side FETs. Power levels below about 200W into 8Ω favor complementary bridges, but finding appropriate P-channel devices becomes increasingly difficult above this level. Figure 3 shows one-half of the bridge using complementary FETs in a full BTL

(bridge-tied-load) configuration.

The output bridge uses 60V-rated Vishay-Siliconix SUD10P06-280L and SUD15N06-90L devices that can switch 15A in about 20 nsec. Parallel operation of FETs is a good choice for several reasons. First, current sharing minimizes dissipation and allows good thermal design with minimum heat-sinking. Parallel operation also enables the FETs to operate on the most linear part of their on-resistance versus current curve. This

detail is important, because any on-resistance modulation can cause odd-order harmonic distortion. In this example, parallel devices reduce output impedance, resulting in an increase in damping factor, improving the tightness of the bass response. Here, the output impedance is 0.2Ω —equivalent to a damping factor of 40 with an 8Ω load.

A lowpass filter removes high-frequency content before the speaker. Typically, these

filters require a frequency response that's flat up to 20 kHz, but some audio standards demand a controlled response up to 96 kHz. For good audio performance, the inductors provide excellent linearity characteristics and a tolerance of only a few percentage points. They also require minimal series resistance and core losses and must not saturate under heavy load conditions. Distributed-air-gap, iron-powder cores are often the best choices.

The system's PWM frequency affects output component values, and the 1-MHz architecture minimizes inductor size. This high-frequency switching also enables a higher filter-cutoff frequency, which helps meet specifications such as SACD (super-audio compact disc) with a high degree of tolerance to variable-impedance loads. Filter capacitors are similarly critical, because poor-quality components can increase THD (total harmonic distortion) and degrade reliability. Use RF-quality, low-ESR (equivalent-series-resistance) types.

Adequately protecting an amplifier is not trivial. Any scheme must operate correctly with widely varying dynamic conditions, both in signal level and output-load impedance, but must trip if a fault occurs, regardless of audio conditions. Ensuring protection with shorts at the smallest signal levels can be more important than the more obvious high-power conditions.

First, consider whether you're protecting the amplifier, the load, or both. Then, consider the fault conditions that you need to guard against. Conventional protection ensures that users can abuse the external connections of an amplifier

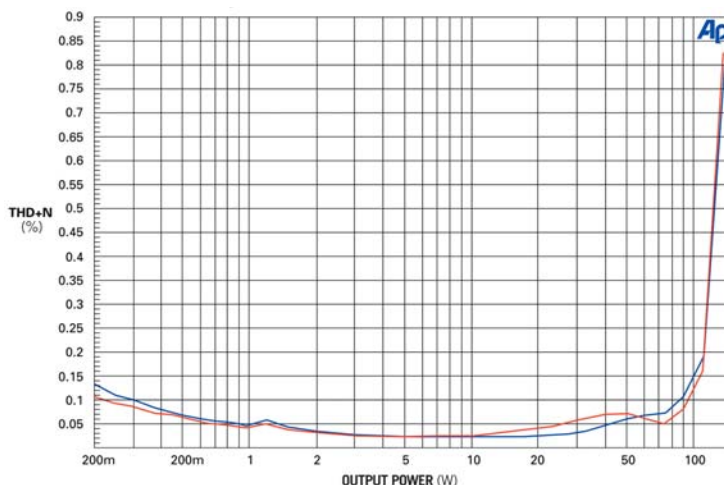

Figure 5

A 10-m Ω sense resistor in the bridge power rail causes minimal additional distortion.

without damaging it or the speaker. However you apply it, the protection circuit must trip whenever a short across the amplifier outputs or a short from any amplifier output to ground occurs.

SHORT-CIRCUIT PROTECTION

Current-sense circuits normally provide short-circuit protection, either within the system's power supply or directly at the bridge; a combination of both can offer excellent protection. Current limits in the power supply are easy to apply, because they're often parts of the standard SMPS (switch-mode-power-supply) circuit; applying protection in the bridge is somewhat more difficult. **Figure 4** shows a bridge-sense circuit that protects an amplifier that can deliver 150W into 8Ω . **Figure 3** shows the sense components. Sense resistors between the positive bridge supply and each half of the output bridge ($10\text{-m}\Omega R_1$ in **Figure 3**) develop voltages proportional to the current flowing in the bridge. These voltages supply the differential inputs of the protection circuit—in this case, a ZDT751 dual-PNP transistor (Q_8). When an overcurrent of sufficient magnitude occurs, the differential voltage drives "mute" low.

Circuit setup is important. For example, the balance between C_{10} and R_{15} desensitizes the inputs to fast transients. Output-filter-inductor choice is critical, too, because circuit operation relies on nonsaturating inductors. Select components with a saturation current well above the expected amplifier's maximum output current under normal conditions. In this example, inductors with satura-

tion current well over 20A suit a trip point of 12A. Also consider speaker impedance variations. In this case, allowing for a 4Ω load requires a balance between trip-point selection and the current that's necessary for full power into 4Ω . This circuit setup cuts in somewhat below 3W, a level low enough to allow safe operation of the amplifier driving into shorts with the lowest of signal levels.

Power supplies have

a profound influence on audio performance. As a result, a sense resistor in the bridge supply rail can influence audio quality. In practice, measurements confirm that the $10\text{-m}\Omega$ sense resistor causes minimal degradation (**Figure 5**).

Open-loop Class D amplifiers demand extra consideration for the influence of support circuits. The system's power supply, particularly the supply to the bridge, is a major contributor (see **sidebar** "Power-supply quality and capacity for details" with the version of this article at www.edn.com). Poor system clocks may also degrade sound quality (see **sidebar** "Keep system clocks clean," also with the Web version of this article).

The study of many implementations of digital-input Class D circuits shows how easy it is to create an amplifier that doesn't do itself justice in measurement or sound quality. Although time and space do not permit this article to consider every angle of design, practical implementation and attention to the key areas can significantly enhance performance and potentially produce the best sounding digital amplifiers. □

AUTHOR'S BIOGRAPHY

Dave Brotton is a technical marketing manager for audio products with Zetex plc, where he has worked for 13 years, originally as product-line manager for power-management products and for the last four years developing the Zetex Class D switching-audio program.

TALK TO US

Post comments via TalkBack at the online version of this article at www.edn.com.