

WITH AN UNDERSTANDING OF THE UNDERLYING PHYSICS, YOU CAN OFTEN GO A LOT FURTHER IN ANALYZING TRANSMISSION LINES THAN YOU CAN BY MANIPULATING DOZENS OF COMPLEX EQUATIONS. THE BASIC INFORMATION THAT YOU NEED TO GET STARTED IS RIGHT HERE.

Analyze transmission lines with (almost) no math

As wireless designs become more prevalent and as digital designs reach higher and higher frequencies, a thorough understanding of transmission-line theory is becoming increasingly important. With the aid of graphical representations of analog and digital signals, you can gain a solid intuitive understanding of transmission lines. Moreover, this approach requires little background in electromagnetic-field theory.

Unfortunately, you probably learned transmission-line theory during a few lectures in an electromagnetic-fields class. If so, you learned transmission-line theory with wave equations and a lot of difficult math. In addition, you've probably heard that transmission-line effects become apparent at higher frequencies, but rarely does anyone explain why. Why are transmission-line effects usually noticeable only at high frequencies? What happens at low frequencies? What are the definitions of "high" and "low"? In practice, you can more easily and completely grasp transmission-line theory just by understanding the basic physics.

THE CIRCUIT MODEL

As the name implies, a transmission line is a set of conductors used for transmitting electrical signals. In general, every connection in an electric circuit is a transmission line. However, implicit in most discussions of transmission-line theory is the assumption that the lines are uniform.

A uniform transmission line is one whose geometry and materials are uniform. That is, the conductor shape, size, and spacing are constant, and the electrical characteristics of the conductors and the

material between them are uniform. Some examples of uniform transmission lines are coaxial cables, twisted-wire pairs, and parallel-wire pairs. For pc boards, the common transmission lines are strip-line and microstrip.

In a simple transmission line, a source provides a signal that must reach a load (Figure 1a). The figure shows the transmission line as a pair of parallel conductors. In basic circuit theory, you assume that the wires that make up the transmission line are ideal and hence that the voltage at all points on the wires is exactly the same. In reality, this situation is never quite true. Any real wire has series resistance (R) and inductance (L). Additionally, a capacitance (C) exists between any pair of real wires, because all dielectrics exhibit some leakage, a small

Figure 1

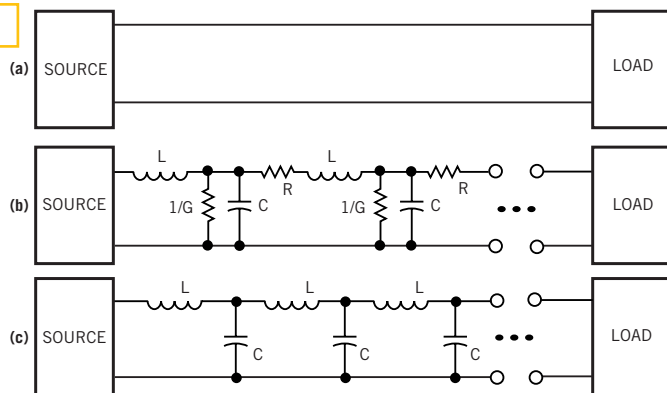

These circuits model a transmission line as an ideal wire pair (a), a lumped circuit that accounts for the nonideal characteristics of real wires (b), and a lossless lumped circuit (c).

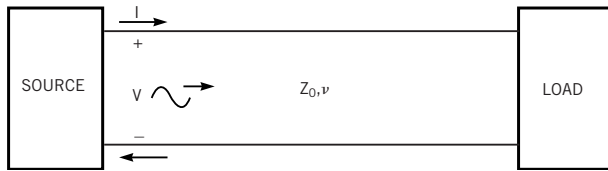

Figure 2 In this waveguide model, I represents the current wave, and V represents the voltage wave, each of which travels along the transmission line. Z_0 is the line's characteristic impedance, and ν is the speed of light in the transmission line's dielectric.

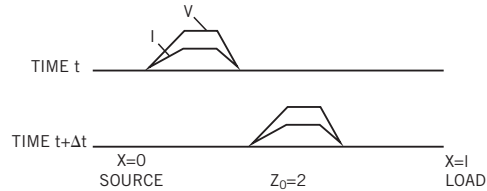

Figure 3 This example of a signal pulse traveling along a transmission line shows the voltage and current waves along the line. The figure represents two snapshots in time.

conductance (G) (that is, a high shunt resistance) exists between the two wires. You can model the transmission line using a basic circuit that consists of an infinite series of infinitesimal R , L , and C elements (Figure 1b). Because the elements are infinitesimal, the model parameters (L , C , R , and G) are usually specified in units per meter.

To simplify the discussion, you can ignore the resistances. Figure

1c shows the resulting LC circuit. A transmission line that is assumed to have no resistance is a "lossless" transmission line. Notice several important points. First, with the LC model, points A and B may

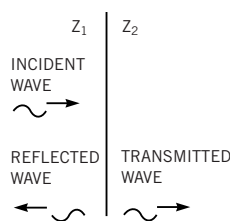

Figure 4 At a boundary between two regions of different impedance, Z_1 and Z_2 , some of the incident energy passes through the boundary, and some is reflected.

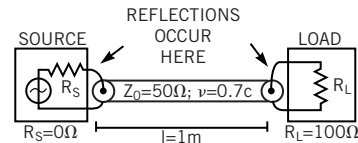

Figure 5 In this transmission-line example, a source and load are connected through a 1m Teflon coaxial cable with a characteristic impedance of 50Ω . Reflections occur at the boundary between the source and the cable because of the difference in impedance. Reflections also occur at the boundary between the load and the cable. (Assume that the source-to-cable and load-to-cable wires are of negligible length.)

be at different potentials. Second, a signal transmitted from the source charges and discharges the line's inductance and capacitance. Hence, the signal does not arrive instantly at Point B but is delayed.

Last, the impedance at points A and B and each node in between depends not just on the source and load resistance, but also on the LC values of the transmission line.

How does this circuit react at different frequencies? Recall that inductive and capacitive reactance depend on frequency. At low frequencies, the LC pairs introduce negligible delay and impedance, reducing the model to a simple pair of ideal wires. At higher frequencies, the LC effects dominate the behavior, and you must not ignore them.

THE WAVEGUIDE MODEL

An equivalent method of characterizing transmission lines describes a transmission line as a guide for electromagnetic waves. With this method, the source sends the electromagnetic signal, which consists of a voltage wave and a current wave, to the load (Figure 2).

The transmission line, which effectively acts as a transmission medium, guides the signal along the way. The signal travels through this medium at the speed of light within that medium. You can calculate the speed of light, ν , in a transmission line from the permittivity (ϵ) and permeability (μ) of the dielectric between the conductors— $\nu=1/\sqrt{\mu\epsilon}$.

For example, if Teflon separates the

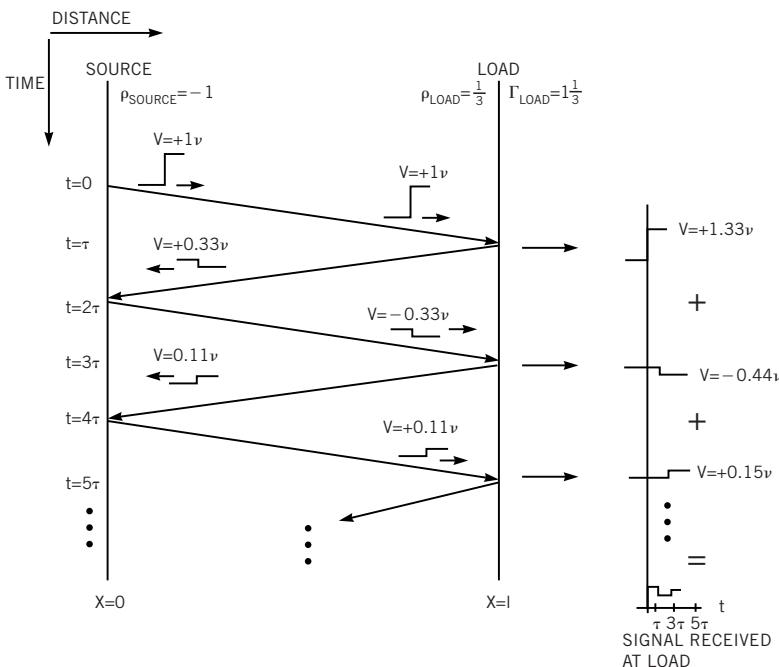

Figure 6 This lattice diagram shows the propagation of a 1V step wave and its subsequent reflections along the transmission line of Figure 5. The waves received at the load are at the right of the diagram. The diagram shows the first five reflections.

pair of wires that makes up the transmission line, the wave travels at the speed of light in Teflon, which is approximately 70% of the speed of light in a vacuum. ($v_{\text{TEFLON}}=0.7c$, where c is the speed of light in a vacuum.) As the signal travels along the transmission line, the voltage wave defines the voltage at each point, and the current wave defines the current at each point. **Figure 3** shows a pulse signal traveling along a transmission line,

with the voltage and current values at each point. Along the entire length of the line, the ratio of the voltage to the current is constant. The ratio is the “characteristic impedance,” Z_0 , and is defined by the geometry of the line and the permittivity and permeability of the dielectric. The characteristic-impedance equations are often complex. For example, if you have a wire-pair transmission line, $Z_{\text{WIREPAIR}} = 1/\pi \sqrt{\mu/\epsilon} \cosh^{-1}(s/d)$, where

s is the distance between the wires and d is the diameter of each wire.

RELATIONSHIP BETWEEN THE MODELS

Now you have two models for a transmission line: a circuit comprising infinitesimal inductances and capacitances with parameters L and C and a waveguide for signals with parameters v and Z_0 . The following equations relate the parameters of the two lossless models: $Z_0 = \sqrt{L/C}$, and

Figure 7

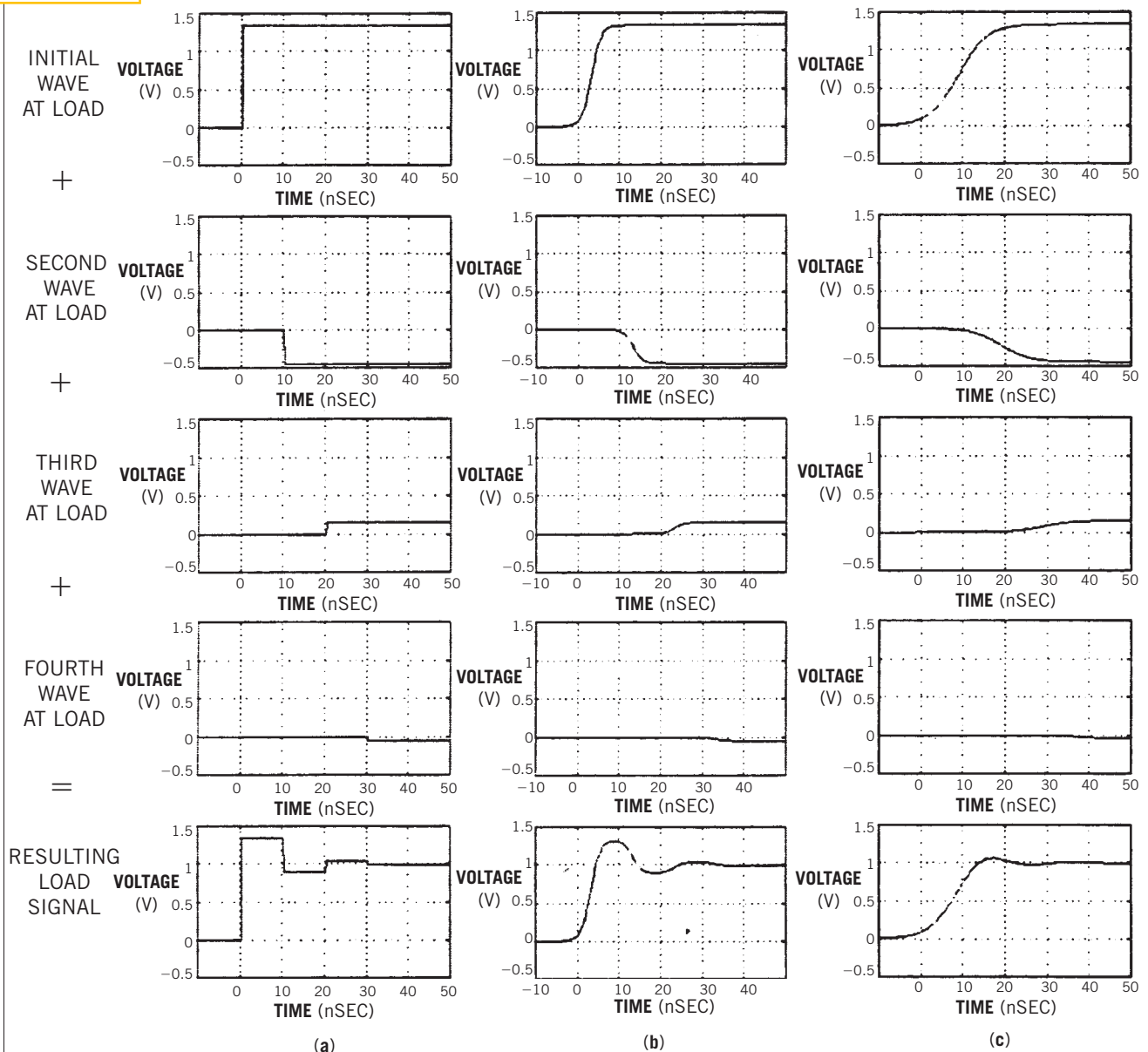

In the circuit of Figure 5, when the source signal is a 1V step with varying rise times, the load receives these signals. (The diagram shows only the first four waves to reach the load.) In (a), $t_{\text{RISE}}=0$. In (b), $t_{\text{RISE}}=5$ nsec. In (c), $t_{\text{RISE}}=15$ nsec.

$v=1/\sqrt{LC}$. Although these models are interchangeable, the waveguide model is usually more useful for transmission-line analysis; the remainder of this article exclusively uses the waveguide model.

REFLECTIONS

Whenever an electromagnetic wave encounters a change in impedance, some of the signal is transmitted and some of the signal is reflected (Figure 4). The interface between two regions of different impedances is an “impedance boundary.”

An analogy helps in understanding this concept. Imagine yourself sitting in a small boat in a pond, looking down into the water. A fish swimming by sees you from below the water’s surface because water is transparent. In addition, you faintly see your image as a reflection upon the water’s surface. Hence, some of the light from your image travels through the water to the fish, and some of the light reflects back to you. This phenomenon occurs because of the difference in optical impedance of water and air. This same phenomenon also occurs at electronic-signal frequencies. The difference between the impedances determines the amplitude of the reflected and transmitted waves. The reflection coefficient, ρ , for the voltage wave is $\rho=V_{\text{REFLECTED}}/V_{\text{INCIDENT}}=(Z_2-Z_1)/Z_2+Z_1$, whereas the transmission coefficient is $\Gamma=V_{\text{TRANSMITTED}}/V_{\text{INCIDENT}}=1+\rho$.

An interesting and often underemphasized fact is that the amount of reflection is independent of frequency and occurs at all frequencies. This fact seems contrary to the common belief that reflections are high-frequency phenomena. The next section should clear up this confusion.

PUTTING IT ALL TOGETHER

In summary:

- A signal traveling along a transmission line has voltage and current waves related by the characteristic impedance of the line.
- Signal reflections occur at impedance boundaries.
- As it travels down the line, a signal has delay associated with it.

These three elements combine to produce transmission-line effects. The first two items imply that a circuit has reflections unless the transmission-line, source, and load impedances are all

equal. The third item implies that reflected waves reach the load staggered in time. An example helps to illustrate. Figure 5 shows a transmission line (coaxial cable) with a source and load connected. The reflection and transmission coefficients for this circuit follow:

$$r_{\text{SOURCE}} = \frac{R_S - Z_0}{R_S + Z_0} = -1,$$

$$r_{\text{LOAD}} = \frac{R_L - Z_0}{R_L + Z_0} = \frac{1}{3},$$

$$G_{\text{LOAD}} = (1 + r_{\text{LOAD}}) = \frac{4}{3}.$$

Let the source produce a 1V step function at time $t=0$. This wave travels down the cable and reaches the load at time

$t=l/v=1/0.7c=5$ nsec. Because the cable’s characteristic impedance (50Ω) is different from the impedance of the load (100Ω), some of the incident wave transmits to the load, and some is reflected by the load. The reflected wave travels back through the cable and arrives back at the source at time $2t$. Because the source impedance (zero) does not match the characteristic impedance of the cable (50Ω), another reflection occurs. This reflection travels toward the load and arrives at the load at time $3t$.

As with the initial wave, the load absorbs some of the wave, and some is reflected. Subsequent waves arrive at the load in this manner ad infinitum, de-

Figure 8

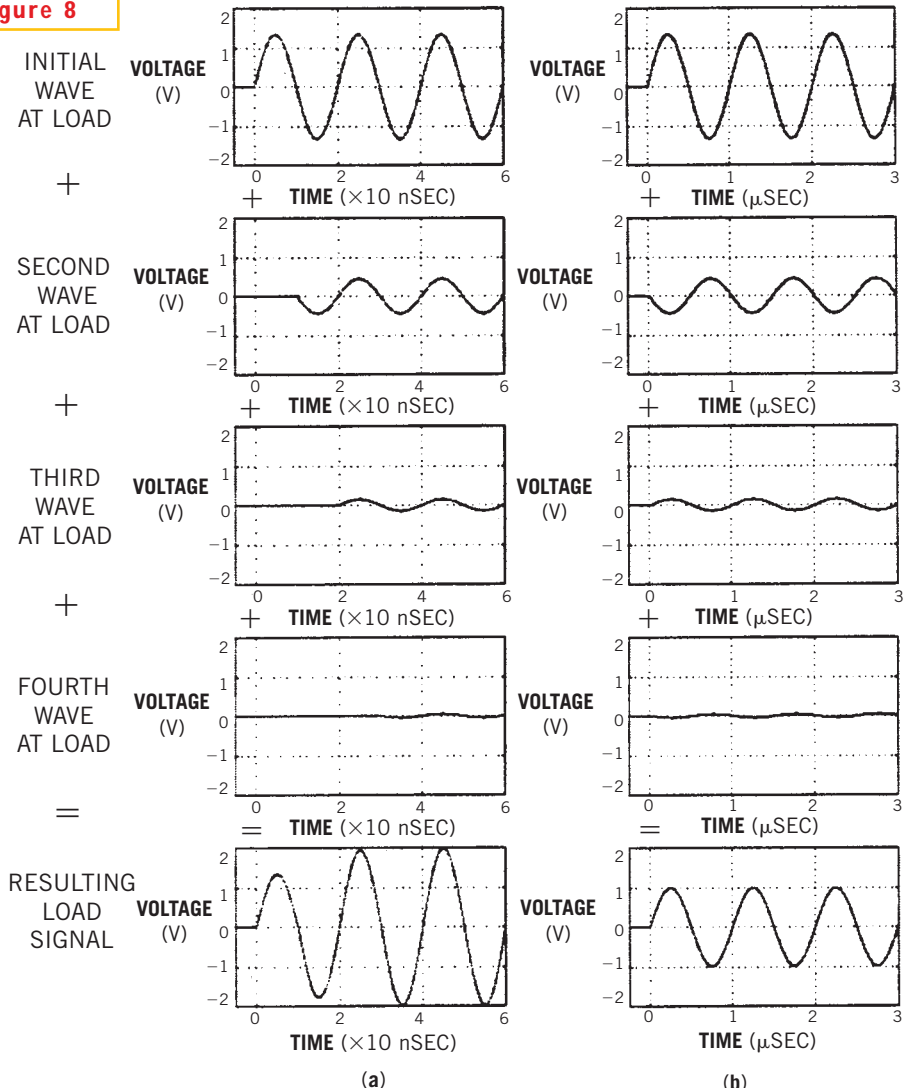

In the circuit of Figure 5, when the source signal is a 1V sine wave at different frequencies, the load receives these signals. (The diagram shows only the first four waves to reach the load.) In (a), $f=50$ MHz. In (b), $f=1$ MHz.

creasing in amplitude after each round trip. The net effect is that the load receives a voltage signal that is the superposition of the initial incident wave and all of the subsequent waves (Figure 6). As this example demonstrates, the resulting signal at the load can look much different from the original source signal. A simple step signal at the source ends up producing a step wave followed by a series of oscillations at the load. These oscillations eventually settle to the value you would expect if you were to ignore the transmission line.

THE TRANSMISSION-LINE EFFECTS (OVERSHOOT AND OSCILLATION) BECOME APPARENT WHEN THE RISE TIME, t_{RISE} IS SHORT COMPARED WITH THE TRANSMISSION-LINE DELAY, t .

In this example, the step signal is an ideal digital wave; that is, a signal with zero rise time. Of course, real-world step signals have rise times greater than zero. Changing the rise time of the step signal changes the shape of the signal that appears at the load. Figure 7 illustrates the load waveforms for the same transmission line using various rise times. When the rise time becomes much longer than the transmission-line delay (t), the reflections get “lost” in the transition region. The effect of the reflections then becomes negligible. It is important to note that, regardless of the rise time, the amplitude of the reflections is the same. The rise time affects only the superposition of the reflections.

The transmission-line effects (overshoot and oscillation) become apparent when the rise time, t_{RISE} is short compared with the transmission-line delay, t . Such signals are therefore in the domain of high-frequency design. When t_{RISE} is long compared with t , the transmission-line effects are negligible; these signals are in the domain of low-frequency design. For most applications, you can consider $t_{\text{RISE}} > 6 \cdot t$ to be in the low-frequency domain.

You can use the same analysis for analog signals. Using the circuit of Figure 5, let the source be a 1V sine wave with a frequency of 1 MHz (period $T=1 \mu\text{sec}$). This signal undergoes the same reflections as the step signal. The amplitude of the waves incident on the load is also the same, namely $+1.33\text{V}$, -0.44 , $+0.15$, $-0.05^{1/4}$. The sum of the series of waves is a 1V sine wave (Figure 8b). In this example, no transmission-line effects are noticeable because the delay of the transmission line is negligible. In fact, the round-trip cable delay is $1/100$ of the signal period.

However, if you increase the source frequency to 50 MHz (period $T=20 \text{ nsec}$), the resulting load signal is quite different, even though the incident waves are of the same amplitude. The delay through the transmission line is no longer negligible at this higher frequency (Figure 8a). In fact, the round-trip delay of the transmission line causes the incident waves to shift 180° . With these phase shifts, the incident waves produce a load signal that gradually builds to a steady-state 2V sine wave. In addition, the load signal shifts in phase from the source signal. Hence, for this circuit, 50 MHz falls in the domain of high-frequency design, and 1 MHz falls in the domain of low-frequency design. For most applications, you can consider a sine-wave period of $T=20 \cdot t$ (or $\lambda=20 \cdot l$) the boundary between the high- and low-frequency domains. □

References

1. Paul, Clayton, and Syed Naser, *Introduction to Electromagnetic Fields, Second Edition*, McGraw-Hill, 1987.
2. Rosenstark, Sol, *Transmission Lines in Computer Engineering*, McGraw-Hill, 1994.
3. Johnson, Howard, and Martin Graham, *High-Speed Digital Design: A Handbook of Black Magic*, Prentice-Hall, 1993.

Author's biography

Ron Schmitt holds a BS in electronic engineering from Cornell University (Ithaca, NY) and an MSEE from University of Pennsylvania (Philadelphia). During seven years in the industry, he has worked on embedded-system design, signal processing, digital and RF communications systems, and analog test equipment. He has one patent pending and has co-authored a conference paper on antenna-signal processing.