

BY RON MANCINI

Anatomy of a voltage-feedback op amp

One of the most common requests I get from engineers is for a comparison of voltage-feedback op amps and current-feedback op amps. It is impossible to determine which one better suits a given application without explaining how each op amp functions. Here, I tackle the voltage-feedback op amp (**Figure 1**).

Precision and CMR (common-mode rejection) are the voltage-feedback op amp's strong points, but its slew rate and frequency performance are subpar compared with those of a current-feedback op amp.

In **Figure 1**, the long-tailed pair, Q_1 - Q_2 , and the current source, I , form the input stage of the voltage-feedback op amp. Perfect matching of Q_1 and Q_2 causes equal collector currents when the base voltages are equal. Another way to appreciate this matching is to realize that grounding the base of Q_1 effectively puts the base of Q_2 at ground because the voltage drops are equal. The semiconductor process matches the input transistors the best it can. When that matching is inadequate, the manufacturer employs other means of making the transistors appear matched, such as trimming deposited resistors or blowing links.

Connecting $IN-$ to $IN+$ eliminates the input differential voltage; thus, the input voltage becomes common-mode. Moving the common-mode input voltage up or down 1V does not change the collector currents in Q_1 and Q_2 , so the circuit rejects the common-mode voltage. The common-mode-voltage rejection is complete as long as you don't violate the collector- or emitter-current source compliance.

Matching Q_1 and Q_2 ensures that the base-emitter voltages and current gains, β , are equal. An equal base-emit-

ter voltage ensures that no input-offset voltage exists, and equal current gains ensure that the input currents are equal. Equal input currents eliminate the input-offset current, so you can employ external resistors to turn input current into common-mode voltage that the op amp easily rejects. The voltage-feedback op amp's precision stems from its matched input stage.

The voltage-feedback op amp is a voltage-gain device; hence, it has high-

impedance nodes, such as those at the collectors of the various transistors. Coupling high-impedance nodes with the slightest stray capacitance causes early frequency roll-off and poor high-frequency performance. Furthermore, the node driving the buffer limits the circuit's slew rate. The prebuffer-stage slew-rate equation is $dV/dT=I/C$. The output-current source fixes I , and the junction capacitance fixes C , so the internal design of a voltage-feedback op amp limits its slew rate. This type of circuit has limited slew-rate performance unless you can design the circuit to enhance its slew-rate performance. But enhanced slew rate always comes at the costs of increased power and often decreased gain and precision.

In general, the voltage-feedback op amp has excellent precision and CMR coupled with mediocre frequency and slew-rate performance. **EDN**

Ron Mancini is a staff scientist at Texas Instruments. You can reach him at 1-352-569-9401, rmancini@ti.com.

MORE AT EDN.COM

Go to www.edn.com/051027rm and click on **Feedback Loop** to post a comment on this column.

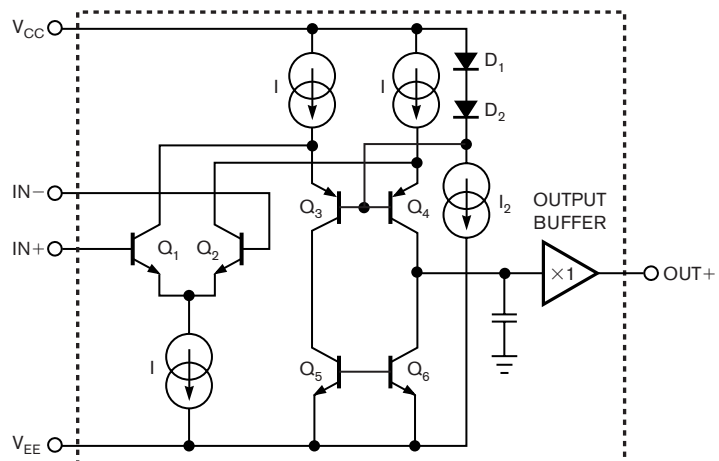

Figure 1 A voltage-feedback op amp uses a long-tailed pair to obtain precision and common-mode rejection.