

# RF-interference-design considerations for portable-device batteries

**TODAY'S USE OF EVER SMALLER YET MORE COMPLEX BATTERIES IN MOBILE-COMMUNICATIONS APPLICATIONS REQUIRES DESIGNERS TO USE ADVANCED DESIGN TECHNIQUES TO PROTECT BATTERIES FROM RFI. USERS MUST CONSIDER A NUMBER OF PHENOMENA AND DESIGN ISSUES TO ENSURE THAT THEIR DESIGNS CONFORM TO BOTH RF AND BATTERY-MANAGEMENT-SYSTEM PARAMETERS.**

Designers face increasing challenges from RFI (radio-frequency interference) when integrating batteries and protection circuitry into systems. At a basic level, a battery pack is an energy-storage device comprising cells and support-circuit assemblies that maximize a host device's performance. Batteries serve as power sources for portable electronics, such as mobile phones, two-way radios, PDAs (personal digital assistants), MP3 players, notebook computers, and wireless scanners. Currently, many portable electronics use Li-ion (lithium-ion)-cell technology (Figure 1). Li-ion battery packs generally have complex protection circuitry, especially if an application requires multiple cells. Typical two-way-radio Li-ion battery packs use two cells in series, and their protection circuitry is more complex than that for a typical single-cell Li-ion battery pack in a mobile phone, for example (Figure 2). Applications requiring many cells in a series, such as those in notebook computers, are even more complex (Figure 3).

Li-ion battery packs need protection circuitry to curb them from overcharging, thereby exceeding their volatility-voltage and -current curves. The circuitry also limits the cells from excessive discharge beyond the undervoltage limit of the cell, which could damage the cell. In addition to the protection circuitry, Li-ion battery packs may also require other circuitry, such as a voltage- or charge-based fuel gauge and electronics, for regulatory-agency approval.

With the growing need for smaller and lighter mobile-communication devices, battery packs usually reside close to their hosts and play major roles in the overall communication systems' size and weight. As a result, compliance with the many RF and battery-management-system parameters becomes increasingly challenging at the system level.

Two-way-radio battery packs normally have two cells in series. Depending on the radio tier, the battery circuit may comprise protection ICs for voltage monitoring and control, voltage- or coulomb-based fuel-gauge circuitry, charge- and discharge-termination circuitry, and circuitry for agency approvals. In a typical notebook battery pack, the circuit can monitor voltage and control multiple cell configurations, charge and discharge ter-

minations, and coulomb-fuel-gauge-based circuitry. Although host applications that require multiple cells may be more susceptible to RFI-design issues due to the volume of electronic circuitry they use, even single-cell-system applications require battery designers to be conscious of the potential for RFI in their designs.

RFI is any undesirable RF signal that interferes with the integrity of electronics and electrical systems. Any electronic system with an interference-signal source and a transmission medium for that source can suffer performance degradation due to RFI. Transmitters, such as mobile phones, two-way radios, commercial radio transmitters, system providers, and other devices, can generate RFI. Conducted transmission of RFI signals occurs through wires, circuit components, and pc boards, for example, and radiated RFI generally implies transmission through space.

## RFI ISSUES IN PORTABLE WIRELESS SYSTEMS

Designers must consider a number of RFI-related issues, including SAR (specific absorption rate), BER (bit-error rate), SINAD (signal-noise-and-distortion) degradation, radiated transmitter power, transmitter instability, system reset and shut-

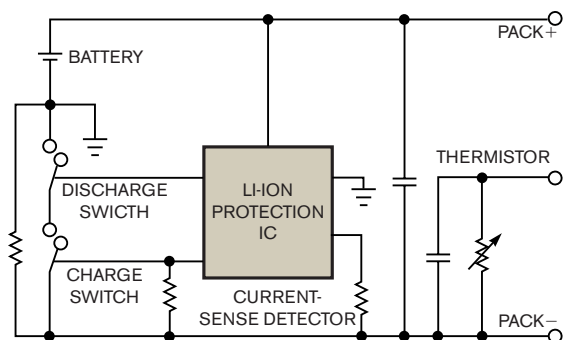

Figure 1 A typical mobile-phone-battery-pack circuit uses one lithium-ion cell.

down, transmitter-frequency pull, receiver hum and noise, transmitter conducted and radiated spurious emissions, RF desensitivity, and discomfort.

SAR quantifies how much RF energy the tissue of a mobile-phone user absorbs. Currently, many mobile-phone designs, including most clamshell designs, use an internal antenna for transmission and reception of RF signals instead of an external antenna due to challenges in miniaturization and the product's industrial design. Designers can use the battery pack as a module to control and manipulate some of the phone's RF-radiated parameters. In the case of minimizing the SAR, a designer could optimize the transmitted-radiated-power level and redistribute and lower the intensity of the localized electromagnetic field. It can be challenging to maximize the transmitted-radiated power while minimizing the SAR performance of mobile phones. Some manufacturers develop their mobile-phone systems to comply with the SAR performance of 1.6 mW/g, which is the FCC (Federal Communications Commission)-compliance limit (Reference 1).

BER is a measure of the phone receiver's sensitivity. Typical radiated receiver sensitivity of phones is approximately  $-102$  dBm at the phone-antenna input, and BER does not exceed 2.44%, whereas higher performance phones have more stringent BER goals (Reference 2). The electronics in pc-board assemblies for batteries can demodulate the RF energy that the phone transmits and can generate noise that could corrupt the voltage supply and data traces to the phone. This conducted noise can then couple or feed into the phone's power-management system and eventually find its way into the phone's receiver system, thereby degrading the receiver-sensitivity performance. Positive-cell batteries use aluminum material, which contributes to the overall lighter weight of the battery pack, but it can be a medium to couple RF-radiated signals to the phone receiver, thereby bypassing the battery electronics. Metal distribution inside the battery pack is another concern that could lead to the degradation of the receiver's antenna efficiency.

Similar to BER, SINAD is a figure of merit of receiver sensitivity for analog-receiver designs. Designers must give the highest consideration to the mechanical assembly and construction of the battery and the layout of the pc board to keep radiated-RF energy from the charging system away from the electrical circuit of the battery, especially the supply lines. Noisy charger power supplies may desensitize the analog-receiver system and cause poor SINAD performance when the battery is charging.

Transmitter-radiated power is a measure of the radiated-RF power of a phone or two-way-radio device. Designers measure this factor to study the ability of a communications device to transmit radiated power through 360°. The total radiated power

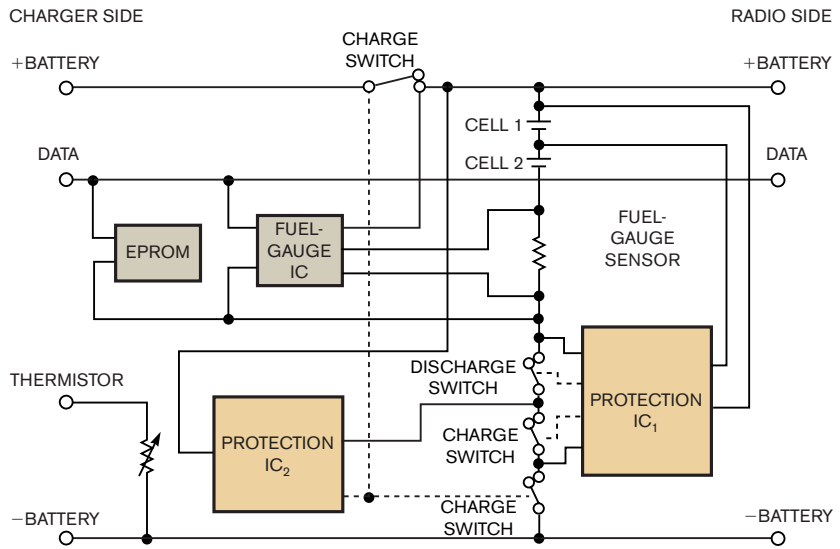

Figure 2 A typical two-way-radio battery-pack circuit uses two lithium-ion cells.

should typically be 33 dBm for the GSM (global-system-for-mobile-communication) band. PC-board layouts, along with the internal battery assemblies and metal compositions in the enclosure's plastics and labels, can contribute to the transmitter-radiated-power performances. Designers should use decoupling and isolation techniques between the host-transmitter system and the battery; otherwise, the communication device's antenna response could vary.

## TRANSMITTER INSTABILITY

Transmitter instability is a measure of the spurious signals a transmitter generates. It can be in the form of spurious signals close to or tens or hundreds of megahertz away from the carrier. If the amplitude of these spurious signals is outside agency-reference-recommendation value, they could cause undue disturbances to other users by entering the receiver systems of other RF bands (Reference 3). The generation of spurious signals from a transmitter could be the result of imposed varying antenna loads, noisy voltage-supply lines to the stages of the transmitter, or noncontinuous battery-voltage supply to RF energy from the host. Parts of the battery assembly may receive and demodulate this energy, creating noise, and then conduct it through the supply lines to the host transmitter.

Designers need to plan for system resets and communication-device shutdowns early in the design process. System resets and shutdowns cause loss of functions and data flow to the host device, which could have an impact in a user emergency. Protection circuitry in Li-ion batteries are more prone to desensitivity due to their lack of immunity to RF energy. If you overlook battery-circuit RF immunity and susceptibility, protective ICs and passive support circuitry may operate at undesired voltage references, altering dynamic and hysteresis limits. This situation could lead to noncompliance of functional voltage- and current-protection parameters. Low-frequency noise, which gen-

erates from demodulation of imposed RF energy on the battery's internal electronics, may couple to the reset- and supply-voltage circuitry of the host's microprocessor. This situation leads to a system reset or improper host-control and -monitoring activities.

Transmitting-frequency pull is the instantaneous frequency drift from the nominal transmission frequency. In the absence of a modulating signal, the transmitting carrier in two-way radios should not deviate or drift from the frequency of interest. The interaction of dangling wrist chains near the host system, for example, is an external interference that could induce frequency pull. Typical transmitting-frequency pull could be tens of kilohertz. In battery packs, large copper fills in pc boards that do not properly correspond with the host reference points and that lack isolation from the host could lead to the formation of electromagnetic currents, which can also induce frequency pull.

Receiver-hum and -noise figures measure the receiver-quieting level in the presence of a strong carrier. (You can obtain the recommended hum and noise values from the agency-reference document.) For a portable battery, the charger circuit, which typically attaches to the battery during charging, can affect hum and noise. Thus, during charging, the battery must reliably prevent charger-switching noise from coupling into the host.

## CONDUCTED AND RADIATED EMISSIONS

Spurious emissions are critical RF-system-performance considerations. Poor spurious-emission performance can disturb nearby electronic devices. Designers must eliminate conduct-

ed or radiated spectral impurities. Conducted and radiated spurious emissions must meet certain regulatory requirements. The higher order harmonics of the carrier cause unwanted signals to couple into the battery assembly, such as the cell or the pc board. Transmitted harmonics should be within  $-36$  dBm for frequencies lower than 1 GHz and  $-30$  dBm for frequencies of 1 to 4 GHz (Reference 4). Thus, designers must properly bypass the spurious signals and carefully lay out the pc board to prevent undesired signal coupling. The close proximity of the battery to the RF circuit on mobile phones makes it even more difficult to prevent RF-signal coupling.

RF discomfort normally occurs when a high concentration of RF energy accumulates on metallic parts. RF discomfort causes a tingling, or "ant-bite," sensation that some users feel on their skin when in contact with the exposed metal parts and when the host device is in transmitting mode. This sensation may be challenging to reproduce in low-band to VHF two-way radios in which the transmitter power is normally higher than in other portable radio bandsplits. A typical portable battery uses metal parts for the battery-supply contacts and thus could possibly cause RF discomfort when a user touches the metallic parts. Designers must carefully place common-mode-current paths and the impedance to unwanted RF energy in battery and pc-board layouts.

The use and management of battery data are crucial in most portable communication devices. Designers must accurately characterize battery life and other smart features and ensure that the specs do not breach protection limits. Battery data can be

**MORE AT EDN.COM**

**We encourage your comments!**  
Go to [www.edn.com/ms4141](http://www.edn.com/ms4141) and click on Feedback Loop to post a comment on this article.

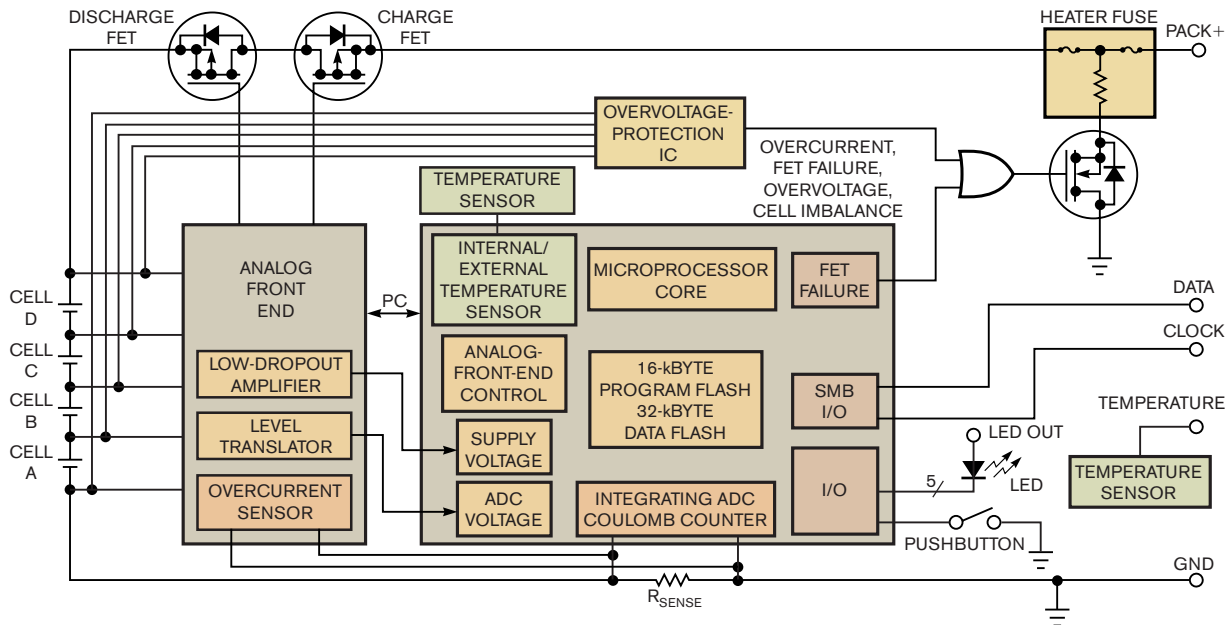

Figure 3 A typical notebook-computer battery-pack circuit uses multiple cells.

static or dynamic, depending on the extent and complexity of the host's requirements. Static battery data, such as chemistry, charge terminations, voltage approximation, and gauge, are less prone to RFI, because these variables involve hard-coded information. However, loss of battery information may result from the battery EPROM's lack of immunity to RFI. Dynamic battery data relates to real-

time fuel gauging, monitoring of charge and discharge cycles, monitoring usage of aftermarket chargers, more accurate battery-capacity estimation, and estimation of battery-pack usage. These variables are more prone to RFI and low-frequency-noise interference.

Batteries are integral parts of the overall host system, but designers integrating them into systems face increasingly

challenging obstacles in developing approaches that minimize RFI. Maintaining differential-mode-current cancellation, curbing common-mode RF currents, decoupling functional circuitry, maintaining uniform ground references, and minimizing the host's RFI susceptibility are challenging goals that designers should focus on early in the design cycle. A poor layout could result in a waste of time and resources on "Band-Aid" fixes. Because little isolation lies between the host and the battery-pack assembly, mobile-communication batteries must include good RF-design techniques and guidelines to meet the host system's performance goals. Understanding the host's critical radiation blocks and reference points is crucial, so that designers can plan proper layout and bypass techniques to minimize or eliminate the effects of RFI. **EDN**

## REFERENCES

- 1 "Radio Frequency Safety," Federal Communications Commission, Office of Engineering and Technology, [www.fcc.gov/oet/rfsafety/sar.html](http://www.fcc.gov/oet/rfsafety/sar.html).
- 2 European Standard ETSI EN 300 607-1, [www.etsi.org](http://www.etsi.org).
- 3 Telecommunications Industry Association TIA/EIA-603, [www.tiaonline.org](http://www.tiaonline.org).
- 4 European Standard ETSI EN 300 086-1, [www.etsi.org](http://www.etsi.org).

## AUTHORS' BIOGRAPHIES

*Macvien Krishnamurthi is a principal staff engineer at the Penang Design Center of Motorola (Malaysia). Since joining Motorola in 1994, Krishnamurthi has developed two-way radios and battery packs for Motorola and other OEMs. He earned his electrical-engineering degree from the Engineering Council United Kingdom in 1993 and has since 1999 been a chartered engineer with the Institution of Electrical Engineers in the United Kingdom.*

*Ahmad Kamal Shamsuri is a technical lead engineer at the Penang Design Center of Motorola (Malaysia). Since joining Motorola in 2000, his responsibilities have included leading the development of notebook-computer batteries for OEMs. He is currently developing base-station transceivers for Motorola. He earned a bachelor's degree in electrical engineering from Union College (Schenectady, NY).*