

Power-management techniques for multimedia mobile phones

ASIA AND OTHER MARKETS ARE RACING TO LAUNCH DIGITAL TV AND STREAMING VIDEO AND MUSIC IN HANDHELD FORMATS. THESE TECHNOLOGIES BRING BENEFITS, BUT DESIGNERS STILL FACE THE CONSTRAINTS OF INCORPORATING MULTIMEDIA FUNCTIONS IN SMALL FORM FACTORS IN THE FACE OF INCREASING BATTERY LIFE.

Now that Asia and other markets race to deploy portable-media technology in the form of multimedia phones, designers must take a step back and consider power-management issues for these handheld devices (see sidebar “Asia looks to multimedia as the new ‘new thing’”). Consumers have come to expect the small form factor and the long battery life on the 2G and 2.5G GSM (Global System for Mobile communication) or CDMA (code-division multiple-access) phones available today. The challenges to mobile-phone designers now are to include the new multimedia functions and still maintain the small, low-profile form factor of the handsets, as well as their long battery life. No one wants to deploy a handset that users would have to recharge after two hours of operation.

New application processors can deliver the necessary media-processing functions, but it comes at the price of higher power consumption. And the new devices change the users’ profiles, as well. New audio and video functions mean longer audio-playback time, so audio amplification needs to be more efficient. Moreover, as audio and video functions on mobile phones mature, competition will increase the standard of audio quality and output power. All of these added power drains must somehow fit into an already-constrained power budget. Designers must tackle these challenges at all levels of system design, and, although the industry has focused on the digital SOCs (systems on chips) that form the hearts of these handsets, the analog portion of the handset can also help solve these design problems.

To achieve a small-phone form factor, designers commonly

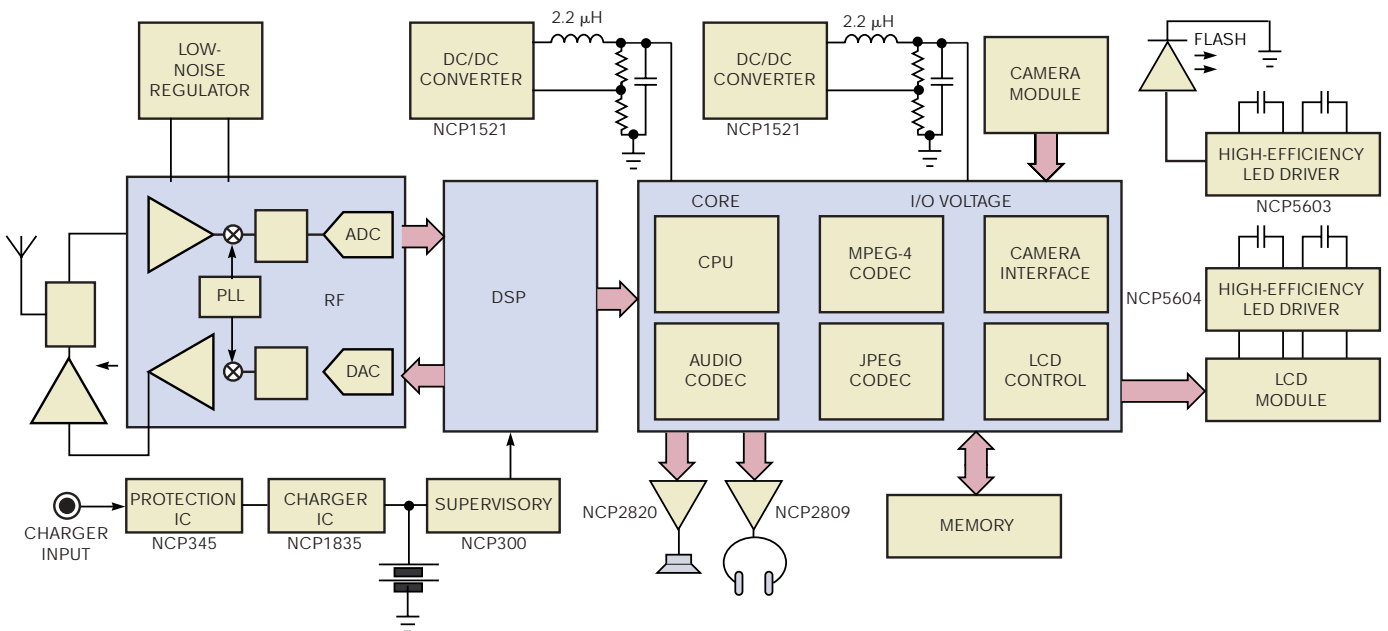

Figure 1 An MPEG-4 platform requires a dc/dc step-down converter with power efficiency greater than 90% and low heat dissipation.

use an integrated power-management unit, which simplifies the power-supply design and makes the end product smaller than it would be if it required the use of several discrete power sections. Paradoxically, however, just as the fast development of multimedia functions in the handsets has increased the need for compactness and power efficiency, it has also led to increased usage of stand-alone voltage regulators. Power-management units are simply too weak to support the increasing power requirements of today's multimedia-rich application processors. And shorter mobile-development-cycle time has not allowed designers to wait for the power-management unit's output power to catch up. As a result, stand-alone voltage regulators supply the extra system power that mobile handsets require.

Thus, designers must carefully select stand-alone regulators. Apart from total cost, the top three criteria in the selection of a stand-alone voltage regulator are low noise, low power consumption, and small form factor. The low-dropout regulator is usually a designer's first choice. Low-dropout regulators are simple to design, they generate no significant amount of noise, and they provide fast response. However, to minimize the power loss and heat that are inevitable with linear regulation, experts often recommend low-dropout regulators only in low-power applications or in cases in which the output voltages are close to the input voltages. Lithium-ion cells in typical handset applications have output-voltage ranges of 4.2 to 3V, making the low-dropout regulator suitable to supply the 3.3 or 3V that analog-I/O circuits commonly require. Despite their inefficiency, low-dropout regulators provide clean power to sensitive circuits, such as RF stages.

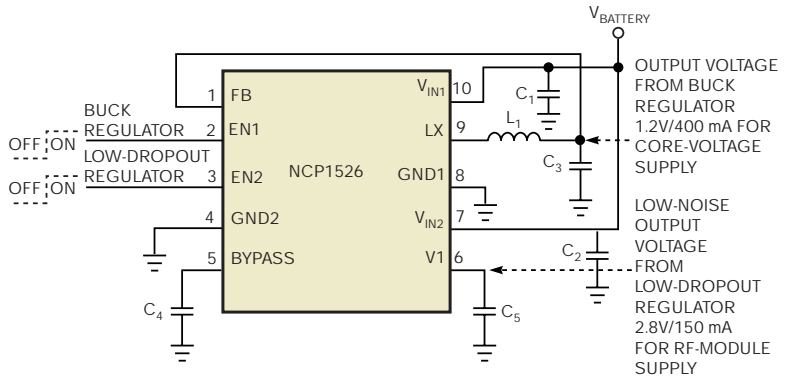

Figure 2 Vendors are beginning to introduce integrated power ICs with both buck and low-noise, low-dropout regulators.

In contrast, microprocessor-core voltages are constantly decreasing because of smaller process geometries; 1.8, 1.5, and even 1.2V have become common in SOCs. At these voltages, the difference between the input and the output voltage of the regulator becomes too large for the low-dropout regulator to achieve acceptable efficiency. If a low-dropout regulator supplies such low core voltage, the loss in power conversion drastically reduces the battery life, and the increase in heat dissipation within the handset enclosure eventually reduces the product's lifetime.

The ideal voltage regulator for new processors is not the simple, quiet low-dropout regulator, but a dc/dc step-down converter with power efficiency greater than 90% and low heat dissipation (Figure 1). An appropriate synchronous step-down converter can supply the core voltage of a low-voltage, deep-submicron chip set, as well as the higher voltage to the I/O circuitry. Buck converters with internal synchronous rectifiers can

ASIA LOOKS TO MULTIMEDIA AS THE NEW "NEW THING"

By Margery Conner, Technical Editor

The Asian market is once again leading the way in innovative mobile-phone applications—this time as go-everywhere multimedia platforms. According to this article's author, Crystal Lam, product-line manager at the Analog Low Power Management Business Unit at On Semiconductor, the new MPEG-4 phones currently popular in Korea and China are the first devices in the coming onslaught of streaming-music and -video phones. "In Asia, portable TV is no longer a

dream," she says. The devices allow users to download and play streaming video and MP3 music. In Asia, portable TV is becoming a reality. With the S-DMB (satellite-digital-multimedia-broadcasting) service Korea launched last May, consumers can watch TV programs on their handsets for a monthly subscription fee. China subsequently introduced the service and launched the first digital-TV-broadcast service based on the DMB standard in Shanghai last

November. Lam predicts that network operators will subsidize the phone price with the revenues from data transfer and subscriptions, making the new multimedia phones available at an affordable price.

Even traditional content providers are taking a leading role in driving mobile-media-technology development. Seven months after the launch of the S-DMB service, Korean TV channels released a free TV-broadcast service based on the

T-DMB (terrestrial-DMB) standard. Despite the reluctance of the network operators to promote the T-DMB phones, Samsung has released seven T-DMB handsets, and LG has presented its T-DMB-enabled PDA with a 3.5-in. LCD screen that can broadcast a TV program during a 2.5-hour window each day. Whichever digital-TV standard prevails, Asian phone manufacturers are all preparing for digital-TV services to enter the market during the next 18 months.

eliminate the use of some external Schottky diodes and offer efficiency of 90 to 96% in full operation over 0.9 to 3.3V with output current as high as 600 mA. Synchronous PWM converters have their own drawbacks in this application, however: They are inefficient under light loads. In mobile phones, the application microprocessors spend most of their time in standby mode. By decreasing their operating power, the microprocessors put the dc/dc converter into the light-loading zone in which efficiency drops to less than 90%. To reduce power consumption in the long-standby time, designers may want to consider using an alternative power supply that employs PFM (pulse-frequency modulation). In this mode, the switching frequency is proportional to the loading, and the overall efficiency thus remains high. Some converters today can automatically switch between modes depending on the demand.

To reduce power-supply size, vendors have moved up to

switching frequencies of 1 to 2 MHz for their buck converters. To demonstrate the effect of the switching frequency, consider three similar converters. A 1-MHz step-down converter uses an optimized inductor-capacitor filter with inductance of 10 μ H and output capacitance of 10 μ F. In contrast, a similar regulator that switches at 1.5 MHz requires respective output-filter-component values of 2.2 μ H and 10 μ F. Similarly, with a 3-MHz oscillation frequency, the optimized inductor-capacitor-filter values are 2.2 μ H and 4.7 μ F, respectively.

This comparison shows that the higher the switching frequency, the smaller the inductor and output capacitor necessary and, thus, the smaller the parts. In multimedia-mobile design with tight pc-board constraints, you should use converters with higher switching frequency to minimize the size and reduce the cost of the passive components. The 3 \times 3-mm SOT23-5 industry-standard package is the common choice for synchronous step-down converters. However, smaller package options, such as chip-scale and DFN packages, are also available to meet even tighter size requirements.

A dc/dc buck converter is the best choice for powering application processors. On the other hand, low-noise, low-dropout regulators typically power RF-sensitive analog circuits with input voltages of 2.8 to 3.3V. Ultimately, only further integration can significantly reduce board area in these designs. Accordingly, vendors are beginning to introduce integrated power ICs with both buck and low-noise, low-dropout regulators (Figure 2).

AUDIO-PLAYBACK CHALLENGES

Portable multimedia functions pose two challenges to audio amplification in mobile phones. First, multimedia phones need to allow continuous music and video playback for at least two hours; long audio-playback time is a key selection criterion on multimedia phones. Second, audio experience on mobile devices must approach that of a home audio system. Users expect clean, powerful stereo audio with bass-boost playback. Today, mobile phones use Class AB audio amplifiers. A typical Class AB audio amplifier offers high audio quality with typical THD+N (total harmonic distortion plus noise) of less than 0.1%. These amplifiers also have good power-supply-rejection ratios, and, thanks to the linear nature of Class AB amplifiers, they present no risk of interfering with the RF system on board. Although they have low power efficiency, they find wide use in short-duration, low-power-audio applications, such as hands-free speakers for voice and ring-tone playback.

But, as MP3 becomes a popular application on mobile-media platforms and playback

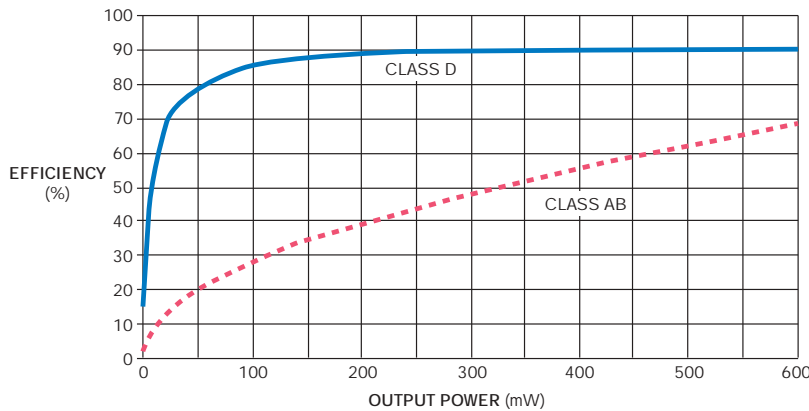

Figure 3 Class D amplifiers offer a stable 85 to 90% efficiency, but the efficiency of Class AB remains 30 to 60%.

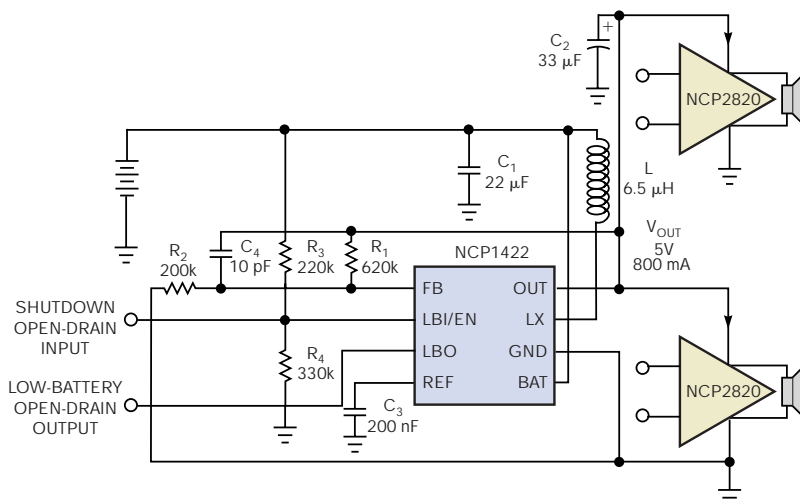

Figure 4 A dc/dc boost converter provides a constant 5V to power the two Class D amplifiers that a stereo application requires.

time increases from a few minutes to hours, Class AB's low efficiency and high heat output will no longer meet the challenge. New designs are now instead employing Class D audio amplifiers. Nominal power consumption for

audio amplification in midrange phones is less than 100 mW, and maximum output power is 700 mW. Comparing the efficiency of a typical Class AB and a selected Class D audio amplifier shows that, at 50 mW, the Class D amp has an efficiency of 80%, whereas the Class AB offers a mere 20%. For the higher power operating range of 100 to 500 mW, Class D amplifiers offer a stable 85 to 90% efficiency, but the efficiency of Class AB remains 30 to 60% (**Figure 3**).

Due to their low efficiency and hence high heat generation, Class AB amplifiers in these applications cannot be robust enough to deliver output power higher than 1W without saturation or distortion. Thanks to the switching-mode operation in Class D amplifiers, they efficiently amplify the audio signal and thus can deliver higher output power to support high-volume audio playback. You can achieve as much as 1.4W output to an 8Ω speaker at a THD+N of less than 1%. Because low-frequency sound generation requires considerable power, especially with small speaker areas, this extra amplifier power helps to boost the bass sound, which is an important feature in music and gaming audio playback.

MP3 players—and, most likely, future mobile-media devices—often use an external cradle with 4Ω stereo speakers. This requirement provides another challenge to the audio amplifier, which you can best meet by operating the device at a higher voltage, such as 5 to 5.5V. This approach, in turn, requires a dc/dc boost converter to provide a constant 5V to power the two Class D amplifiers that a stereo application requires (**Figure 4**).

EMI CONSIDERATIONS

A Class D amplifier operates in a constant-frequency PWM-switching mode. Thus, it may produce EMI that can interfere with nearby RF-circuit operation. Two key techniques can help prevent EMI interference with the RF system. First, you

MORE AT EDN.COM ▶

Go to www.edn.com/ms4191 and click on Feedback Loop to post a comment on this article.

should place the Class D amplifier close to the speaker. In the case of stereo applications, you should use two monophonic amplifiers rather than a single stereo chip, so that you can place the two amplifiers next to the two speakers, usually at the sides of

the handset. Apart from this step, designers should also connect an EMI filter, such as a ferrite bead, to the output of the amplifier. The EMI filter acts as a band-pass filter to remove the high-frequency switching signal from the audio output before it can propagate along the traces to the RF circuitry.

Market forces are driving mobile-multi-media devices to replace mobile phones in both mature and developing markets. In these new mobile-media centers, vendors are upgrading processors and releasing chip

VENDORS ARE UPGRADING PROCESSORS AND RELEASING CHIP SETS AT SUCH A PACE THAT INTEGRATED-POWER APPROACHES FROM THE POWER VENDORS CAN'T KEEP UP.

sets at such a pace that integrated-power approaches from the power vendors can't keep up. Thus, designers of the new mobile-media centers must turn to discrete power and audio devices to meet the extra system requirements and to deliver new models with short time to market.

New synchronous buck converters offer high efficiency, are easy to design-in, and help designers to develop small systems with low system cost. Similarly, Class D audio amplifiers with high power efficiency prolong audio-playback time to meet new market demand. Class D amplifiers also deliver high output power to support the compelling audio playback critical in MP3, TV, and gaming functions. **EDN**

AUTHOR'S BIOGRAPHY

Crystal Lam is a product-line manager for ON Semiconductor's analog low-voltage power-management products in the company's Toulouse, France, development center.