

# Capacitive touch sensors fulfil early promise

CAPACITIVE PROXIMITY SENSORS EMBODY AN OLD CONCEPT THAT TODAY'S IC TECHNOLOGIES PROMISE TO DELIVER. VENDORS VIE TO WIN OVER NEW MARKETS IN THE AUTOMOTIVE, CONSUMER, AND INDUSTRIAL MARKETS USING METHODS THAT COMBINE TRADITIONAL ANALOGUE WITH THE BEST OF CONTEMPORARY DIGITAL TECHNIQUES.

While electronics engineers struggle to embed more functions into ever-shrinking size and power-consumption footprints, product designers wrestle with a bigger but similarly unchanging picture. Their perspective, which resonates from the boardroom level to the consumer-product media, is that cutting-edge packaging and smart user interfaces ultimately sell products—sometimes despite the underlying hardware. In the automotive industry, similar presentation concerns dominate, even though the technologies are complex, and the value of the end product is high. For instance, Osram recently won the 2006 PACE (Premier

Automotive Suppliers' Contribution to Excellence, [www.trcpg.com/pace.htm](http://www.trcpg.com/pace.htm)) innovation award for its color-on-demand LEDs, which offer car makers the opportunity to specify custom hues that differentiate their products from those of their competitors. Such simple stratagems sell. Meanwhile, back on the shop floor, it's always been a high priority for automation vendors to offer user interfaces that are as simple yet powerful as possible, as well as utterly reliable.

These and countless other applications depend upon two primary elements: switches and displays. Although displays and enabling technologies, such as OLEDs (organic LEDs) attract massive attention, the lowly switch partner often receives scant recognition. But this technology moves on too, with a new generation of capacitive touch sensors providing compelling reasons for designers to reconsider their switch-panel choices. Traditionally difficult to design and unreliable in sensitivity and stability, today's touch switches are often cheaper and more reliable than their electromechanical counterparts. Gone too are the days when choosing a touch switch or panel required custom manufacture, as a growing variety of capacitive-sensing ICs makes even one-off designs affordable. Crucially, such developments offer product designers the scope to differentiate

their equipment and offer electronics engineers the benefit of owning their designs. So, how good are these new parts, and how easy are they to design with?

## AN 87-YEAR-OLD CONCEPT

The product of Russian-government-sponsored research into proximity sensors, the Theremin sensor, which Leonard Theremin invented in 1919, is possibly the first commercial use of capacitive sensing. The device senses the proximity of a musician's hands to a pair of antennae that modulate the frequency and amplitude of two heterodyning oscillators that form the heart

of the world's first electronic music synthesizer. Continuing this theme, in 1972, designer David Cockerell at Electronic Music Studios penned the KS keyboard as a sequencer for the company's range of voltage-controlled synthesizers (Reference 1). This intriguing device boasts a 30-note touch-sensitive keyboard whose inputs rely on the TTL-logic characteristics of two 74150 16-to-one-line multiplexers. These devices scan the keyboard, taking their clock inputs from a 4-bit binary ripple counter. A network biases the inputs to the multiplexers to hold them close to their switching threshold—a finger press is enough to shift the level above that threshold. At this time, the appropriate data-selector output goes low to latch the 4-bit code and the multiplexer's identity to create a 5-bit address that represents key position.

## SHUNT FIELD SENSES OBJECTS

Surprisingly perhaps, today's capacitive sensor ICs from Analog Devices, Cypress Semiconductor, Freescale Semiconductor, and Quantum Research Group similarly demonstrate different approaches to sensing. These vendors also offer evaluation kits that make it easy to compare the ease of design and relative complexity and robustness of their technologies (see sidebar "What's in the box?"). Here, "robustness" refers to the ability to reliably determine key-press information across a range of user profiles and environments. Any touch sensor has a background capacitance, a signal level, or both that is a product of its environment and a higher level, beyond which the sensor records a key-press event. Accordingly, mobile devices present significant challenges. One minute, the mobile may be in free space, and, the next minute, its

### AT A GLANCE

- \* Capacitive touch sensors challenge switches and resistive panels.
- \* Available ICs demonstrate diverse sensing methods.
- \* A 3-D-sense field widens applications.
- \* Charge transfer minimizes sense-plate count.
- \* Evaluation kits speed robustness and ease-of-use assessment.

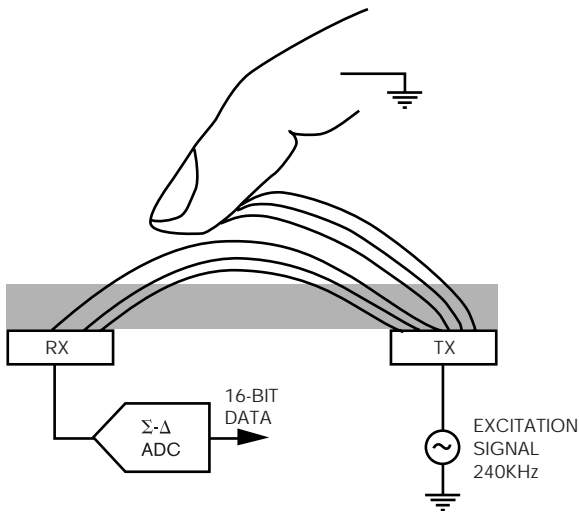

Figure 1 Shunt capacitance disturbs the sense field that the AD7142 creates.

user places it beside a PC, cell phone, or other electronics that emits unpredictable frequency components at various field strengths (see sidebar “Don’t try this at home!”). Electrostatic discharges are another potential source of mistriggering, and water and other contaminants can cause similar problems. To overcome these and other issues, such as drift with temperature and time, touch-sensor ICs often embed logic and analogue subsystems that continually calibrate the system. By characterising individual channels, such techniques can also accommodate keypads that have widely different user fingerprints and key profiles, improving both detection and the product designer’s options.

These issues are clear to see using the new AD7142 from Analog Devices as an example and apply in varying measure to any of the other chips that are available today. With a base price of \$1.09 (1000), the AD7142 packs 14 capacitance-to-digital-conversion channels into a 32-pad, 5×5-mm leadless CSP. A key feature of this device is its self-calibration capability, which is essential for its mobile-electronics target market. The sensor works by generating a 240-kHz square-wave signal that drives one of each button’s electrodes to create an electric field that a partner electrode assesses. A switch matrix multiplexes the receiver electrodes’ signals to a 16-bit sigma-delta ADC that performs the capacitance-to-digital transformation. The presence of a finger or another conductor shunts the

completion of a conversion sequence, and an event on the device’s general-purpose I/O pin. At the measurement level, each input channel has its own 2-bit field within a configuration register that determines how it connects to the CDC (capacitance-to-digital-converter) block. The options are no connection, connection to the CDC’s positive or negative input, and connection to the bias rail that drives an external shield conductor. This facility provides the flexibility that’s necessary to support different sensor types. For instance, one button might connect to a single CDC input, or two buttons might connect differentially across both inputs. Either of these options requires a single stage of capacitance-to-digital conversion to resolve a single button press; pressing both buttons in the differential arrangement results in the recognition of neither. A slider requires the differential connection and two conversion stages, in which the first detects sensor activation—that is, the proximity of an object—and the second resolves its relative position. The chip’s sequencer supports as many as 12 stages of conversion per measurement sequence, and you can optimise performance by balancing the number of conversions and the decimation rate that the acquisition block applies. ADI recommends setting the time for a full conversion sequence to 35 to 40 msec.

The proximity-detection function is important for holding off the chip’s internal recalibration routine, which runs after every conversion sequence to assess

background capacitance of the appropriate button, causing the ADC’s output code to change; when this change exceeds a programmable threshold value, the sensor registers a key press (Figure 1)

Each of the AD7142’s channels has its own result register that the host reads via an SPI or I<sup>2</sup>C interface. The chip can generate interrupts to signal a transition through a sensor’s threshold level, the

changes in background capacitance. Registers allow designers to adjust the calibration hold-off time for the chip’s full- and low-power operating modes, which helps guard against a user’s finger hovering over the key for an excessive time, disabling the calibration routine. The moisture that the user’s finger deposits on the panel can create this hovering effect, so forcing a recalibration helps the sensor to maintain optimal detection performance. The chip’s adaptive threshold-and-sensitivity algorithm continuously monitors each sensor’s output levels, automatically scaling the threshold levels to compensate for changes in sensor area due to factors such as different finger sizes.

All capacitive sensors incur some trade-off between the amount of power a device uses to support its detection technique, the frequency of its key-press updates, and the overall power budget. The AD7142 offers full-power, low-power, and device-shutdown operating modes. In full-power mode, all sections of the device are on, and it continuously converts and recalibrates at a constant rate. The low-power mode reduces conversion frequency to, for instance, once per 400 msec until it detects a key press, whereupon it reverts to a 40-msec sequence. (These timings are programmable.) Meanwhile a proximity timer counts down, and—providing that no other key presses occur—the sensor returns to its 400-msec cycle. For these timings, low-power mode reduces the chip’s full-power drain of around 1 mA to an average level of approximately 50 µA. The shutdown mode reduces quiescent current drain to about 2 µA.

### 3-D IMAGING ENLARGES USAGE

Brad Stewart, a product specialist at Freescale, explains that the company’s MC33794 electric-field sensor accommodates as many as nine sensing and two reference electrodes to suit challenging automotive applications, such as seat sensors that require large-area, 3-D imaging to optimize airbag deployment for differing occupants and seating positions. Available at a base price of \$2.22 (1,000), the 54-pin SOIC device features an active shield driver to compensate for capacitive effects when using coaxial cables to connect to remote sensing plates. Critical internal nodes, such as the detection-signal level, are available from device pins for connection to the analogue inputs of a microcontroller, which can then

take measurements and apply corrections. An ISO-9141 physical-layer interface eases connection to this 10.4-kbps, UART-based bus that's one of three legally mandated onboard diagnostic-communications structures that North American vehicles must support.

The MC33794 applies a 5V p-p, 120-kHz sine wave to its sensor electrodes through a 22-k $\Omega$  resistor that forms one-half of a voltage divider; the sensor electrode and a partner ground plate form the other half. The choice of a relatively low-frequency sine wave minimises EMC issues, including interference avoidance with the AM radios that most American vehicles carry. A synchronous demodulator, rectifier, and lowpass filter smooth the resulting signal level that an object creates by shunting a greater proportion of the drive signal to ground.

The capacitance between the electrodes is proportional to the area of the electrodes and the dielectric constant of the separating material, and it is inversely proportional to the distance between them:

$$C = \frac{k\epsilon_0 A}{d}$$

where  $k$  is the material's dielectric constant,  $\epsilon_0$  is the permittivity of free space,  $A$  is the area of the plates in square metres, and  $d$  is the distance between them in metres. Stewart notes that the relationship suits alternative sensing applications, such as open/closed-door detection and compensating imbalance in spinning appliance drums: "Because interelectrode capacitance is inversely proportional to distance, our sensors are finding new markets in correcting wobble in driers and other domestic appliances," he says. He says that designers tend to regard electrode design as something of a black art, whereas the reality is that it's most often simple: "We recommend a 10 $\times$ 10-mm area for a button on standard FR4" (Reference 2). Automatic icemakers and refrigerator-defrost systems are also potential applications, along with sensing liquid levels or even detecting spills around a stove's burners (Figure 2).

Targeting use in consumer and general industrial applications, the new MC34940 dispenses with automotive-specific features to drive as many as seven electrodes and a shield from its 24-pin wide-SOIC

package. This arrangement allows the use of as many as 28 touch-pad sensors. Freescale offers C-code drivers to implement functions such as sliders, adjacent-key suppression, and periodic recalibration, together with a project environment that runs under the CodeWarrior IDE (integrated development environment) to suit microcontrollers, including the company's recently introduced S08 core-based portfolio. Using the 68HC908QY4 microcontroller to furnish its intelligence, the DEMO1985MC34940E development tool includes embedded-code samples along with a PC-resident application that's written in a pre-.Net version of VisualBasic, enabling programmers to modify this code to suit requirements. Available now, the kit costs \$57.65; the price for the MC34940 is \$2.12 (1,000).

### MIXED-SIGNAL $\mu$ Cs SCAN PANELS

Cypress adopts a different sensing technique with its CapSense products. Its CY8C21x34 and CY8C24x94 build on the company's PSoC (programmable-system-on-chip) mixed-signal microcontrollers to implement relaxation oscillators. In this arrangement, the capacitance between a sensor electrode and a ground electrode form the timing element in a sawtooth generator. A constant-current source charges the capacitor until the voltage ramp reaches a threshold, whereupon a switch discharges the capacitor and the cycle repeats (Figure 3). Because the capacitance and its charging current determine the oscillator's frequency, the circuit senses the presence of the user's finger by measuring the difference in frequency that the accompanying capacitance increase causes. Cypress publishes a range of application notes that cover the operational principles and describe suitable pad layouts for this type of sensor.

Available in four package options from 16-pin SOIC to 5 $\times$ 5-mm MFL, the CY8C21x34 features 8 kbytes of flash, 512 bytes of RAM, and both I<sup>2</sup>C and SPI ports. The CY8C24x94 uses a 56-pin, 8 $\times$ 8-mm MFL to accommodate 16 kbytes of flash, 1 kbyte of RAM, SPI, and a full-speed USB port. Guide pricing spans \$1.90/1,000 to \$2.85/1,000, respectively. Steven Berry, marketing manager for CapSense products at Cypress, observes that the company's PSoC devices differ from conventional microcontrollers in offering various combinations of analogue

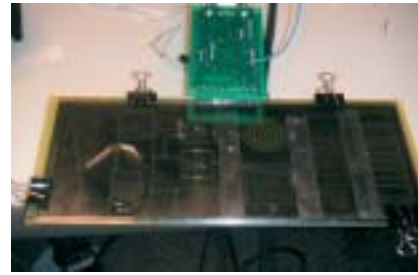

Figure 2 Freescale's 3-D e-field sensor expands application opportunities.

blocks to complement a configurable digital core: "The core is a state machine to which users can add function blocks, such as UARTs and timers, simply by setting registers," he says. Similarly, the technology supports analogue-function blocks that include continuous-time devices such as op-amps, comparators, and resistor arrays, as well as switched-capacitor circuits that build filters, ADCs, and DACs. A floorplanner tool within the PSoC Designer suite provides a method of visualising the necessary connections: "PSoC Designer is a step up in abstraction that enables users to think in terms of connecting up modules on a pc board," says Berry. Each module has a data sheet that describes electrical specifications and suggests design strategies. The development environment provides drivers and APIs (application-programming interfaces) that include register settings and function calls in C or assembly code. Crucially for many small systems, the embedded microcontroller can enable single-chip systems.

Berry concurs that at the application level, handheld devices present the greatest challenges due to their unpredictable environments. To compensate, an API allows designers to periodically run a correction algorithm that updates each electrode's baseline-level register. You can set both noise and detection thresholds, enabling continual software correction for systems that experience frequent environmental changes. You can also balance the device's power consumption and detection sensitivity by adjusting the sensing algorithm to accommodate sensor patterns and material overlays. Berry notes that, although the constant-current-source approach rejects voltage changes, the company is working on a patentable method for temperature compensation to maintain the current

## WHAT'S IN THE BOX?

Before taking the time to check out competing capacitive touch-sensor technologies, many designers question the technology's major historic failings: lack of robustness and difficulty of design. As a result, vendors offer an array of evaluation boards that help prospective users assess such issues for themselves. The vendors kindly submitted a few examples for our inspection.

Familiar to many exhibition attendees, the Scrollwheel-3 from Analog Devices comes in a 67×67×28-mm ABS plastic box that encloses two pc boards. The top of the main board carries an ADuC841 microcontroller, a Cypress CY7C68013A-56 microcontroller, a 3.3V regulator, and a pair of clock oscillators. On the underside, there is a

USB transient-voltage-suppressor chip, a 64-kbit serial EEPROM that the Cypress chip boots from, and a hex-Schmitt-trigger gate. Two pushbutton switches provide for reset and program inputs, with a four-pin header making the ADuC841's transmitter/receiver lines available for an external device programmer. Similar hardware appears on the company's Eval-AD7142 board that appears on the Web for \$199, and this version offering buttons of different sizes, two 64-position linear sliders, and an eight-way switch. The Scrollwheel demo unit is naked by comparison, with its second assembly home to the AD7142 chip and a 27-mm-diameter pc board that forms the sensor. A 10-way flat cable interconnects the two assemblies.

At first glance, this hardware seems to be a lot to perform a simple function. In practice, the Cypress microcontroller provides only the USB interface, and the company does not recommend it for new design. Many simpler and cheaper alternatives support stand-alone operation for microcontrollers without the interface, such as FTDI's chips that convert between USB and RS-232 for easy connection to any UART. The ADuC841 controls the sensor chip through an SPI connection and communicates with the USB-interface chip through general-purpose I/O. The heart of the system is the sensor chip and, most interestingly, its sensor board. Eight equally sized radial sectors divide the flexible substrate into sensing zones. ADI notes that, although simple button sensors require no driver software, joy pads and sliders require host-resident routines to interpolate between sensing zones. The company estimates the code footprint for a slider at about 3 kbytes of ROM and 500 bytes of RAM and recommends a 1-MIPs or better processor.

The Scrollwheel software adds a sample MP3-player application to the freely downloadable evaluation-board package. The demo hardware downloads this single-sensor application at start-up, and the evaluation board loads demo routines for its buttons and sliders. Common features include the ability

to set the AD7142's operating mode and to inspect and modify any of its many registers, and the software continuously reports the capacitance-to-digital converter's output values. The Scrollwheel demo shows the user's finger position around the eight sensing zones and reports 128 possible output codes. The application differentiates between finger position and finger taps that can signal mode changes in a target application. The demo also graphs the relative output from the sensor zones in histogram format, plotting the overall output against a timeline (Figure A). These facilities provide a method for assessing the effect of changing the chip's register settings. The default values demonstrate smooth and continuous response, with minimal jitter between adjacent code values.

For \$89, the CY3212 CapSense training kit from Cypress comprises a 127×77-mm base-board that's home to a CY8C21001 chip, plus a 5V linear power supply, a buzzer, and sensing areas for seven buttons and a linear slider. The special-purpose CY8C21001 emulates all the CapSense PSoCs (Programmable System on Chips), making available an emulation port. A pair of headers accesses the chip's I<sup>2</sup>C port and the in-system programming lines for the supplied PSoC MiniProg programmer, together with a mini-USB cable for connection to a host PC.

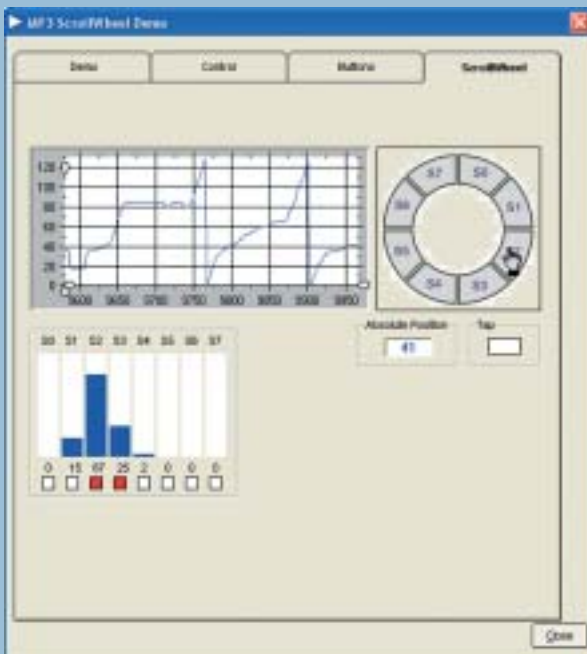

Figure A ADI's Scrollwheel software graphs finger position versus relative signal strength over its 128-point area.

An RJ45 socket attaches the optional ICE-Cube in-circuit emulator, which is the key component of the \$599 CY3215DK PSoC-development kit. A two-line, 16-character LCD board plugs into the base to display system status.

The CD contains installation files for PSoC Designer and PSoC Programmer, together with support files and documentation. As always, it's wise to check for updates and additional material on the Web, which revealed a set of eight new CapSense projects, as well as the SP3 update to PSoC Designer 4.2. It's first necessary to install the base application before downloading 77 Mbytes of zipped update files that add the crucial CapSense User Module. Because the first kit release didn't include the second CD that

now furnishes training material, this test uses the CapSense projects that appear on the Web. All that's then necessary is to unzip the package and run the .soc project file of interest from within PSoC Designer and download it to the board using the MiniProg programmer, which powers the CY3212 board from the host's USB port.

Or, at least, that's the theory; plugging in the programmer produced the familiar "new-hardware-found" message from XP Pro, with a prompt demanding configuration files that the installer deposits in the application's drivers subdirectory. Running any of the examples from PSoC Designer subsequently failed to compile, returning "Operation terminated. Compiler license invalid." At this point, it

became clear that these button and slider examples require the \$145 extra-cost C compiler, which, according to the online store, was out of stock, quoting delivery of four to six weeks. Happily, the zip-download files contain precompiled hex files in the respective output subdirectories, which trying to compile the C sources using the "rebuild-all" command clears. Beguilingly, PSoC Designer promises all of the features of a full-blown integrated development environment that programmers will find appealing, plus drag-and-drop block-configuration controls that justify fuller investigation than is possible here (Figure B).

Downloading the respective button, slider, and buttons-and-slider files onto the board using the MiniProg and running

the code confirms that the hardware is operational. Although the LCD reports robust button behaviour given a normal finger test, the slider examples require precise finger positioning to return accurate positional data. At first, the slider-only example appeared more responsive than the buttons-and-slider version in this respect, when it proved possible to lose the LCD's messaging even with a finger right in the centre of the sensing area; interestingly, this response seemed to improve with time. No sensor would detect a finger on the opposite side of the pc board, and all required a positive touch rather than sensing proximity, which characteristics could prove beneficial in some applications. Although executives refuse to address this point, industry rumour has it that PSoC technology powers the iconic iPod's wheel interface.

Dispensing with the need for configuration software, Quantum's QT160 detects as many as six key presses through glass panels as thick as 100 mm—which explains the sturdy construction of its \$75 E160 evaluation board (Figure C). Targeting detection in permanently powered indoor environments, the \$3.50 (1,000) chip requires an external 10-MHz resonator to clock its logic and typically consumes 2.5 mA from a 5V supply. The demo kit includes a 9V battery, which proves that no power-supply ground connection is necessary for the charge-transfer

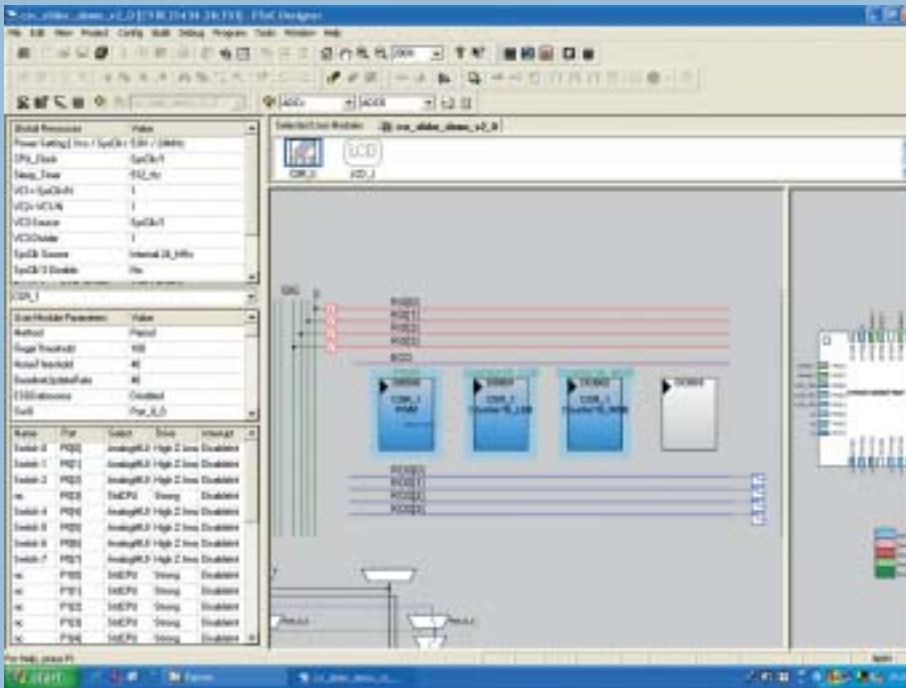

Figure B Cypress PSoC Designer offers a full-blown IDE together with powerful drag-and-drop controls.



Figure C Quantum's QT160 six-key sensor offers stand-alone operation.

technique to function reliably. The QT160 features adjacent-key suppression,

demonstrator, allowing a maximum of three concurrent detections.

with capacitors setting the sensitivity for individual channels, and generates six active-high logic-level out-puts. It also supports a toggle-switch mode and adds maximum recalibration-time-out options that cater for unusually long key presses. The adjacent-key-suppression capability is an especially prominent feature of this

The company's E401 demo slider assembly similarly requires no user programming. Costing \$95, the kit comprises a QT401 device and linear-format, 18-electrode pc board that adheres to an ABS plastic panel. The aggregate sensing distance through FR4 and ABS is about 3 mm. A 10-wire unshielded cable connects the board to an interface box that contains an SPI-to-USB converter built from a Microchip PIC16F873A microcontroller and an FT232BM UART-to-USB-interface chip from FTDI. (Quantum usefully

includes another cable-and-connector assembly for users who wish to construct their own interfaces, together with a couple of spare QT401s.) The product's CD contains a small PC-resident routine that continuously polls the board to return finger position. At more than 10 mm in the track centre and little less in any other plane, the system's proximity-detection ability is impressive. With a positive finger press and the default setup values, the response has worst-case jitter of just one value in its 128-point output range.

source's accuracy. A forthcoming part will offer an onboard linear regulator and lower power consumption. Cypress is also exploring new techniques in silicon to reduce susceptibility to noise and other interference—such as ESD events—that firmware must currently accommodate.

### QT CONQUERS WATER

With touch sensors as its specialist market, British fabless-chip designer Quantum Research Group distinguishes itself from broad-line device vendors by offering a wide range of ICs that employ charge-transfer technology. The company's founder and managing director, Hal Philipp, explains that the human body presents about 100 to 300 pF to ground in free space, with a finger contributing only a few picofarads. To meet the needs of applications such as domestic appliances—one of his company's biggest markets—any capacitive-sensing technique must be able to resolve this level in the presence of water and other contaminants, such as the dirt and grease buildup that accompany stove-burner and similar applications.

Referring readers to Larry Baxter's classic text for the best-available coverage of capacitive sensing schemes (Reference 3), Philipp explains that Quantum's QT (charge-transfer) scheme relies on the conservation-of-charge principle: "Our QT sensor is essentially a microcontroller that's programmed to charge a sense plate

of unknown capacitance to a known potential. The sense plate can be anything conductive, from a pc-board pad to an area of optically clear indium-tin-oxide over a display screen." By measuring the charge on this plate after one or more charge/transfer cycles, the chip determines the sense plate's capacitance; objects such as a finger disturb the charge on the sense plate to allow detection. Philipp emphasizes that applying a low-impedance source to the sense electrode and then sampling with a narrow width pulse ensures reliable finger detection even in the presence of substantial moisture levels: "From an electrical-admittance viewpoint, water films have a far greater disturbing effect at low

frequencies due to the two-dimensional RC network formed by the film itself and its capacitive loading to the local environment," he observes.

Quantum refines this model by switching  $V_{CC}$  to the sense electrode using a spread-spectrum, burst-mode technique. Randomising the charge pulses and inserting long delays between bursts minimises EMC issues and further boosts robustness. Individual pulses can be 5% or less of the intraburst pulse spacing, which also lowers power consumption and cross-sensor interference: "Most noise sources [that affect capacitive sensors] are either monotonic or occupy narrow bandwidths," Philipp says. The company's sensors typically use sam-

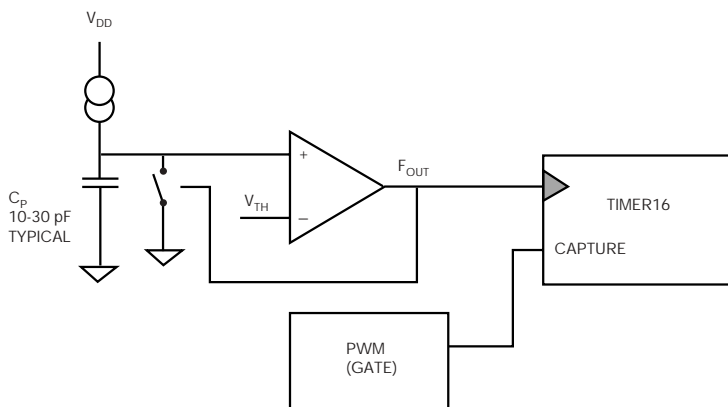

Figure 3 PSoc sensors from Cypress measure frequency changes in a relaxation oscillator.

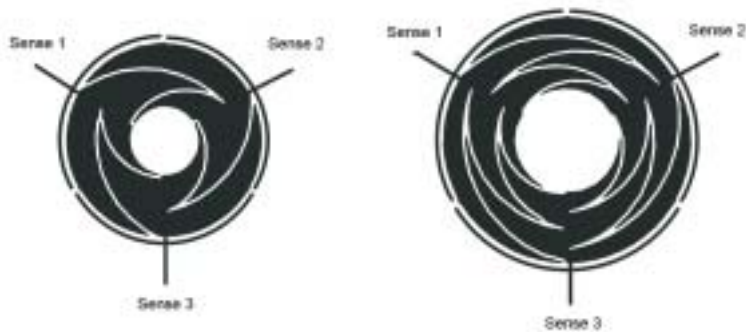

Figure 4 Quantum's wheel sensors can use a 3-terminal interleaved metal structure to re-solve 128 points.

pling frequencies in the 100 kHz range, but some of its devices realise effective frequencies of 10 MHz and more by using sample times in the order of 100 nsec. The result is a sensor that can resolve objects through more than 50 mm of glass or proportionally less through materials with lesser dielectric constants. For instance, conventional glass has a value of approximately 7.8, FR4 fiberglass is about 5.2, and most plastics are approximately 2.7 (Reference 4). In particular, the technology's sensitivity suits replacing resistive touchscreens, in which the traditional requirement for two layers of resistive

## DON'T TRY THIS AT HOME!

You may wonder how robust these touch-sensor technologies appear in the presence of potential interference. Looking around the lab suggests several sources that—although hardly a scientific test—should stimulate erratic responses from any susceptible devices. These sources comprise a phase-controlled dimmer driving a 100W incandescent bulb, a 400W electric drill, a 21-in. CRT monitor, a 433-MHz ISM (industrial/scientific/medical)-band transmitter of 10-dBm output power, and a pair of 900- and 1,800-MHz GSM (Global System for Mobile-communication) cell phones.

Degaussing the monitor and turning the cell phones on within 10 mm or less of the respective sensor assemblies temporarily maximised the electromagnetic field for these sources. Of all the equipment, the electric drill—a virtually unsuppressed relic from the 1970s—is especially nasty as its variable-speed, ac-line-powered motor uses brushes to maximise

torque within the hand tool's small housing. The peaky nature of its low-frequency RF interference also promises to compromise sensitive sensors whose operating frequencies typically lie within a few hundreds of kilohertz.

In practice, ADI's Scrollwheel became confused when it was close to the triac-switched dimmer, losing its ability to resolve a finger press and requiring a power cycle to restore normal operation. Similarly, the Cypress board lost control of its buttons-and-slider routine, but the individual buttons and slider routines correctly identified a finger's presence—even with ac-line-switching conductors lying directly across the panel's face. The Quantum slider detected the mains wiring's proximity at approximately 10 mm but also worked faultlessly while showing slightly more pronounced output-code jitter. Holding the drill a few millimeters above the panel while repeatedly starting and stopping its motor soon crashed the Cypress

board, but the ADI and Quantum products somehow ignored this severe irritant.

By comparison, moving the QT401 board around—let alone close to the face of the CRT, where it registered the mesh as a valid press—consistently generated signal errors that required a software restart, presumably to reset the chip's baseline-signal calibration. This same exercise caused the ADI board not to recognise its sensor area correctly, requiring power cycling to fix. None of these antics could disturb the Cypress board, even when running its buttons-and-slider routine and degaussing the monitor with the board pressed against the CRT's face. Unsurprisingly maybe, none of the boards showed any deviant behaviour in the presence of any of the RF sources, with the Quantum product simply detecting the metallic antenna's proximity, just as for any other object.

Arriving just in time for inclusion here, Freescale's

development kit for its MC34940 e-field sensor contains the 82×47-mm system board, a sensor board of seven electrodes beneath about 2 mm of clear Perspex, an RS232 cable, and a CD. The system board carries the sensor IC, host microcontroller, power supply, and RS232 interface. A 16-pin header makes it possible to program the 68HC908-series microcontroller via the company's MON08 interface. Running the application software produces a horizontal bar display that charts each of the electrode's signal levels. The sensor detects individual channels or combinations, so user software can also implement a slider function by interpolating between individual channels. The display recorded the dimmer's wiring and the CRT's mesh directly on its faceplate as a presence of about half the value of a finger, and was undisturbed by the electric drill torture. Similarly, none of the RF transmitters upset it.

material compromises light transmission.

To safeguard against false triggering due to momentary unintentional touches, an object's proximity, or ESD events, voting filters require the system to detect a number of successful samples before registering a touch. The signal-processing logic also implements adjacent-key suppression, an iterative technique that repeatedly measures each key's signal strength. It determines the user's true selection by identifying the area of greatest signal-level change. Providing that the selected key's signal remains above a threshold level, the sensor then ignores adjacent keys.

All of the company's chips implement automatic drift-compensation schemes, which Philipp asserts are sufficiently responsive to maintain detection performance in applications such as microwave-oven panels that can experience temperature slew rates of 1°C/sec or more. An algorithm periodically assesses each input's baseline-signal level when no one is touching the sensor, adjusting the detection threshold to maintain constant sensitivity. Depending on the type of QT device, designers set the threshold level using reference capacitors or software: "Although the signal change that's necessary to ensure reliable detection doesn't change much over time, the baseline level changes quite significantly," Philipp says.

A range of ICs suits single or multiple keys, matrix keyboards, touch sliders and wheels, touchscreens, and combinations of these styles. Demonstrating many features that are common throughout these products, the QT118H is a single-key spread-spectrum sensor that will sense through up to 100 mm of glass while consuming around 12 µA from a 3.3V supply. The chip includes multiplexing logic and a 14-bit-resolution, switched-capacitor ADC that sequentially sources pulses and measures the sensor's charge level, performing recalibrations on the fly. A single capacitor sets the device's sensitivity. The charge-transfer sampling period is 2 µsec, and pulse bursts vary from 0.5 to 7 msec with around 95-msec separation. Consensus logic requires four consecutive active samples to register a

key press, which acts as a debounce filter. Accordingly, following an initial detection, the chip reduces interburst spacing to 20 msec to yield an average response time of approximately 95 msec. Two option pins configure the chip's output pin as an active-low signal of 10- or 60-sec duration; as a 10-sec long toggle-action output; or to generate a 75-msec active-low pulse for every new detection. A three-state "heartbeat" pulse of about 350 µsec superimposes all output types to signal that the sensor is working correctly. Widely available from catalogue distributors such as Digi-Key and Farnell InOne, the QT118H costs less than \$1.00/10,000 in an 8-pin SOIC or DIP, and an evaluation board is available for \$19.95.

Respectively suiting linear sliders and touchwheels, the QT411 and QT511 employ three electrode sections to create a position-sensing touch area. For instance, the QT511 can use just three arcs of interleaved metal that are also usually built on an FR4 substrate (Figure 4). It also forms a cheaper and simpler alternative to the 18-electrode structure and its resistors that appear in the present version of the device's datasheet. While contemporary pc board layout packages such as Pulsonix include polar grids that make it easy to lay out the original 18-electrode radial pattern, Philipp acknowledges that the new structure challenges most board design software: "Our CAD technician used CorelDRAW to create the pattern and then imported a dxf-format file into our pc board design environment." Three sense lines connect to this new structure, with the chip's logic interpolating between electrodes to resolve 128 discrete positions. Three reference capacitors whose values depend on the thickness and dielectric constant of the panel material set the circuit's sensitivity, with the device outputting a 7-bit number via its SPI port. A host microcontroller sets acquisition timings and operating parameters, such as a synchronised mode that optimises ac-line interference rejection. The QT511 costs around \$1.50/10,000 in a 14-pin SOIC.

Quantum's multiple-key sensors provide for setting individual sensitivity for each

key, allowing product designers maximum flexibility in using keys of different sizes and shapes. Further flexibility comes from using a custom microcontroller core, which the company can modify to address the needs of small-system applications, such as food blenders, within a single chip. Philipp concludes, "QT technology has a dynamic range of several decades, and, unlike traditional capacitive sensors, QT sensors don't require coils, oscillators, RF components, special cable, RC networks, or a lot of discrete parts." EDN

---

## REFERENCES

1. [www.hinton-instruments.co.uk/ems/ks.gif](http://www.hinton-instruments.co.uk/ems/ks.gif)
2. "Touch Panel Applications Using MC34940/MC33794 E-Field ICs," Freescale Semiconductor Application Note, AN1985, April 2006, [www.freescale.com/files/analog/doc/app\\_note/AN1985.pdf](http://www.freescale.com/files/analog/doc/app_note/AN1985.pdf).
3. Baxter, Larry K, *Capacitive sensors: design and applications*, John Wiley, 1996, ISBN 078035351X.
4. "Secrets of a Successful QTouch Design," Application Note AN-KD02, Quantum Research Group, August 2005, [www.channel-microelectronic.de/ch\\_html\\_de/halbleiter/sensor-ics/notes/pdf/an-kd02\\_102-touch\\_secrets.pdf](http://www.channel-microelectronic.de/ch_html_de/halbleiter/sensor-ics/notes/pdf/an-kd02_102-touch_secrets.pdf).

---

## CONTACT DETAILS

You can reach Contributing Technical Editor David Marsh at [forncett@btinternet.com](mailto:forncett@btinternet.com).

---

## FOR MORE INFORMATION

Analog Devices <a href="http://www.analog.com">www.analog.com</a>	FTDI <a href="http://www.ftdichip.com">www.ftdichip.com</a>
Corel <a href="http://www.corel.com">www.corel.com</a>	Freescale Semiconductor <a href="http://www.freescale.com">www.freescale.com</a>
Cypress Semiconductor <a href="http://www.cypress.com">www.cypress.com</a>	ImageCraft <a href="http://www.imagecraft.com">www.imagecraft.com</a>
Digi-Key <a href="http://www.digkey.com">www.digkey.com</a>	Osram Opto Semiconductors <a href="http://www.osram-os.com">www.osram-os.com</a>
Electronic Music Studios <a href="http://www.ems-synthi.demon.co.uk">www.ems-synthi.demon.co.uk</a>	Pulsonix <a href="http://www.pulsonix.com">www.pulsonix.com</a>
Farnell InOne <a href="http://www.farnellinone.com">www.farnellinone.com</a>	Quantum Research Group <a href="http://www.qprox.com">www.qprox.com</a>