

Reducing ground bounce in dc/dc-converter applications

ELECTRICAL GROUND, WHICH LOOKS SIMPLE ON A SCHEMATIC, CAN BECOME COMPLEX DEPENDING ON HOW YOU LAY OUT THE PC BOARD. UNFORTUNATELY, GROUND-NODE ANALYSIS IS DIFFICULT. HOWEVER, UNDERSTANDING THE PHYSICS OF GROUND NOISE HELPS TO REDUCE THE PROBLEM.

"Ground bounce" is the amount that a ground return rises or falls relative to the system's 0V reference, and, in a dc/dc-switching converter, ground bounce can be many volts, often because of changing magnetic flux. Magnetic flux is proportional to a magnetic field that passes through a loop area. **Figure 1** illustrates magnetic flux in a simple circuit loop. A voltage source pushes current through a resistor and around a loop of wire. Imagine that you are grabbing the wire with your right hand. Pointing your thumb in the direction of current flow, your fingers wrap around the wire in the direction of the magnetic-field lines. As those field lines pass through the loop, they establish magnetic flux. If you change either the magnetic-field strength or the loop area, the flux will change, inducing a voltage in the wire. **Figure 2** shows the same circuit with an added switch. When the switch opens, current stops flowing, so the magnetic flux collapses, inducing a voltage everywhere along the wire.

Generally, pc-board-ground-plane resistance is a less important source of ground bounce than magnetic-flux change. (The sheet resistance of 1-oz copper is about $500 \mu\Omega/\square$, so a 1A change in current produces $500 \mu\text{V}/\square$ of bounce—a problem for thin, long, or daisy-chained grounds or precision electronics.) Parasitic capacitance is a path for large transient currents to a

ground return. The change in magnetic flux from those current spikes induces ground bounce. Therefore, the best way to reduce ground bounce in a switching dc/dc converter is to control changes in magnetic flux.

In a basic circuit, output current remains constant, but the loop area changes (**Figure 3**). In **Figure 3a**, ideal wires connect an ideal voltage source to an ideal current source. Current flows in a loop that includes ground return. In **Figure 3b**, the switch changes position. The current source is still dc, but the loop area changes and generates a magnetic-flux change, inducing a ground-bounce voltage (see sidebar "Five pc-board-layout configurations affect ground bounce").

BUCK-CONVERTER GROUND BOUNCE

The buck converter in **Figure 4** is similar to the simple circuit in **Figure 3**. At high frequencies, a large capacitor, such as a buck input capacitor, looks like a dc voltage source. Similarly, the large output buck inductor looks like a dc current source. Magnetic flux changes as the switch moves between the posi-

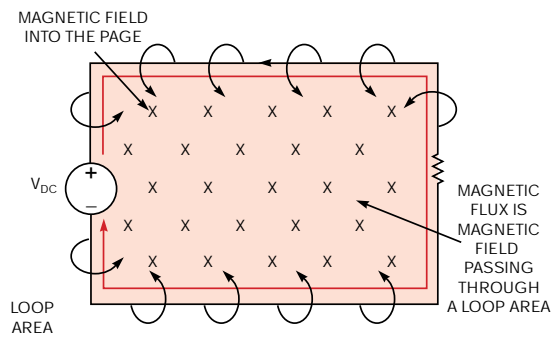

Figure 1 Magnetic flux is proportional to the magnetic field passing through a loop that a circuit forms.

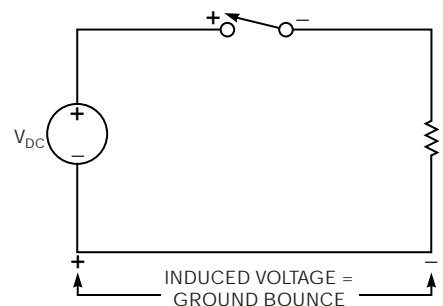

Figure 2 When the formerly closed switch in this simple circuit opens, the magnetic flux goes to zero, inducing a voltage along the circuit.

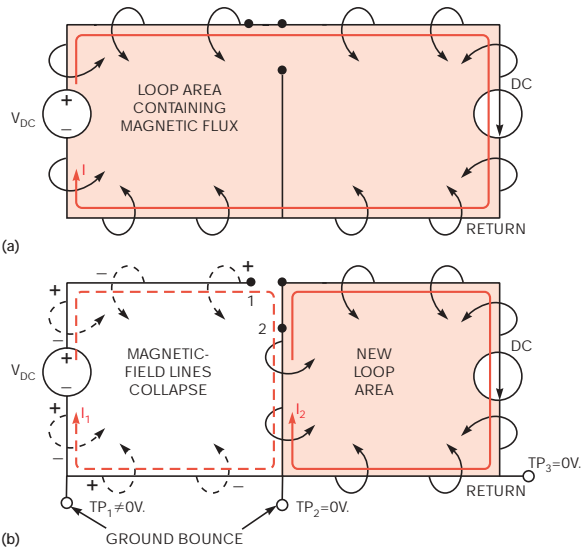

Figure 3 The area of the loop changes based on whether the switch is in position 1 or 2 (a). The collapse of the magnetic field as I_1 goes to zero induces a voltage (b).

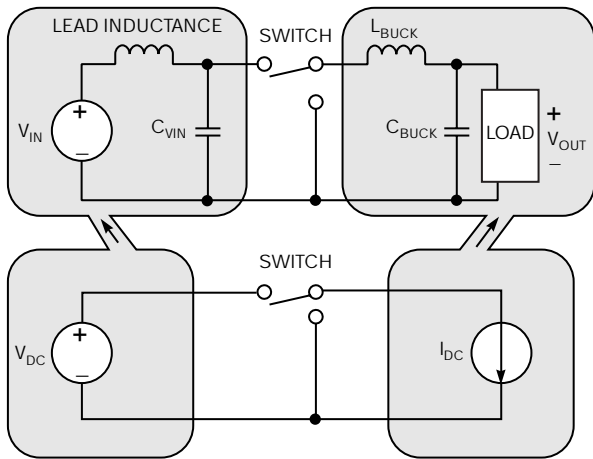

Figure 4 A high-frequency switch sees a large C_{VIN} as a voltage source and a large buck inductor as a current source.

tions (**Figure 5**). The large buck inductor, L_{BUCK} , holds the output current roughly constant. Similarly, C_{VIN} maintains a more or less constant voltage across the parasitic-input inductance, so the input current is also approximately constant. Although the input and output currents are roughly dc, as the switch moves from Position 1 to Position 2, the total loop area rapidly changes in the circuit's middle. This change means that magnetic flux is changing, which in turn induces ground bounce along the return wire.

Buck converters comprise semiconductor switches (**Figure 6**). But, as the complexity increases, the analysis of ground bounce

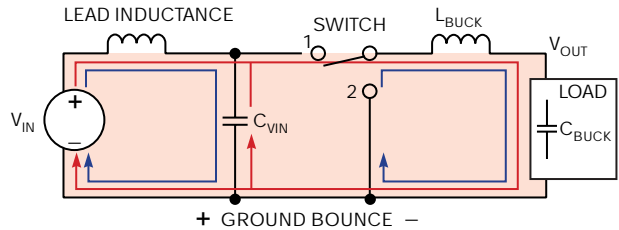

Figure 5 In this simple buck converter, the red current loops indicate the switch in Position 1, and the blue loops indicate the switch in Position 2.

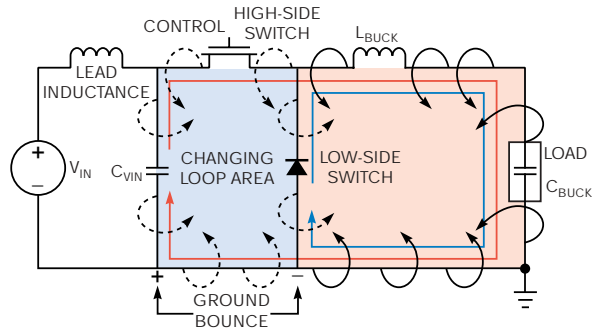

Figure 6 A switching power semiconductor replaces the simplified switch of Figure 5.

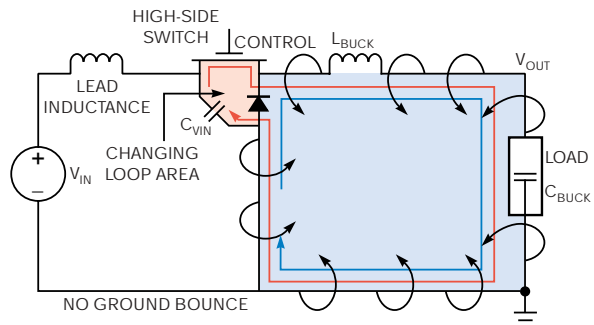

Figure 7 C_{VIN} bypasses the top of the high-side switch to the bottom of the low-side switch, shrinking the changing-loop area and greatly reducing ground bounce.

that changing magnetic flux induces remains simple and intuitive. Knowing that a change in magnetic flux induces voltage everywhere along a ground return brings up an interesting question: Where is true ground? After all, ground bounce means a ground-return trace is bouncing with respect to ground, and you must identify that point.

In the case of power-regulation circuits, true ground needs to be at the point of load. A dc/dc converter delivers quality voltage and current to the load. All other points returning current are not grounds but just return lines to ground. **Figure 7** shows how careful placement of C_{VIN} reduces ground bounce. Capacitor C_{VIN} bypasses the top of the high-side switch to the bottom of the low-side switch, shrinking the changing-loop area. Additionally, the changing-loop area is isolated from the ground return. From the

ground of V_{IN} to the true ground of the load, no loop area or switch-current changes flow from one case to the next. Consequently, ground return does not bounce.

Figure 8 shows an inferior but perhaps typical pc-board layout of the buck schematic in Figure 6. In Figure 8, the high-side switch is on, and dc current flow follows the outer red loop. The low-side switch is on, and dc current flow now follows the blue loop. Note the changing loop area and, hence, the changing magnetic flux. So, this arrangement induces

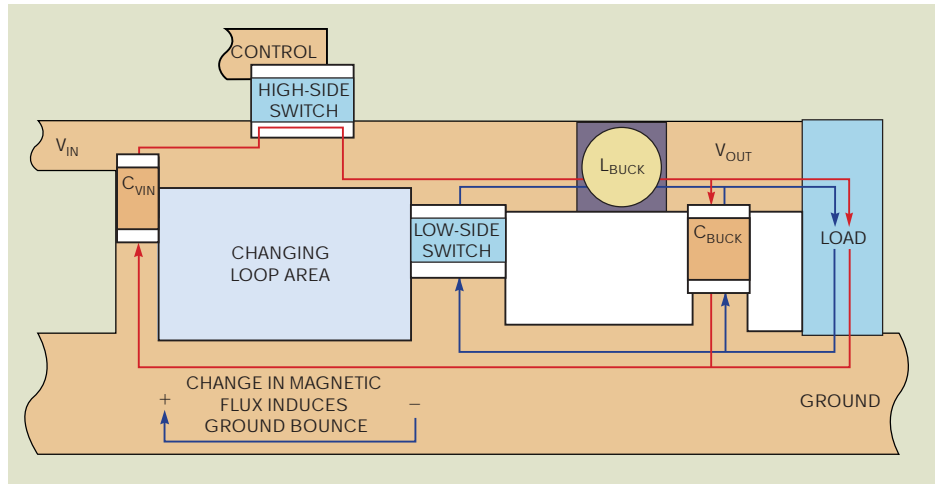

Figure 8 A bad layout causes a large change in current-loop area.

PC-BOARD-LAYOUT CONFIGURATIONS AFFECT GROUND BOUNCE

Conductors that cross at right angles do not interact magnetically: The magnetic field from the vertical trace induces positive and negative voltages that cancel in the horizontal trace (Figure A).

Magnetic-field lines around parallel wires with equal currents cancel everywhere between the wires, so the total stored energy is less than what you would find for the individual wires. Wide pc-board traces have less inductance than narrow traces (Figure B).

Magnetic-field lines around parallel conductors with opposite current flow cancel everywhere outside the conductors and add everywhere inside. If you make the inside loop area small, then the total magnetic flux and, therefore, the inductance will also be small (Figure C). This behavior is the reason that the ac ground-plane return current always flows under the top-trace conductor.

Corners have more inductance because both the vertical and horizontal traces see a magnetic field from themselves as well as from the perpendicular trace (Figure D). A current flows into a top trace, down a via, into a ground plane, and back up a via to the bottom of the source (Figure E). The return current flows, with dc current taking the path of least resistance and ac current taking the path of least impedance. Because top-trace corners and ground-plane cuts increase impedance, you can expect ground bounce. The change in magnetic flux at those points induces the bounce.

The upper trace in Figure F shows good layout practice; the capacitor is in line with the current flow, creating a minimal loop size. The bottom trace, with the capacitor at right angles to the current flow, creates an unnecessarily large loop, resulting in ground bounce.

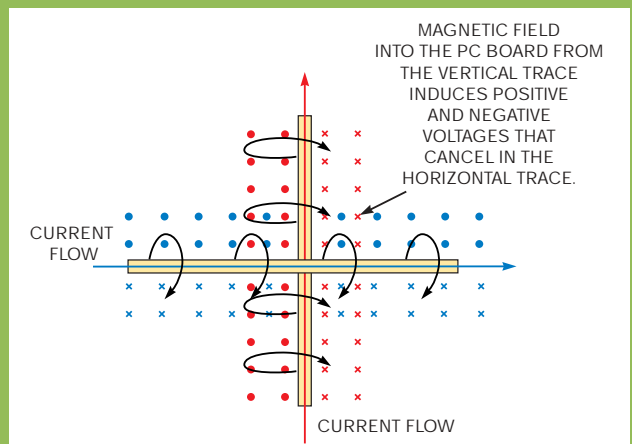

Figure A The magnetic field from the vertical trace induces positive and negative voltages that cancel in the horizontal trace.

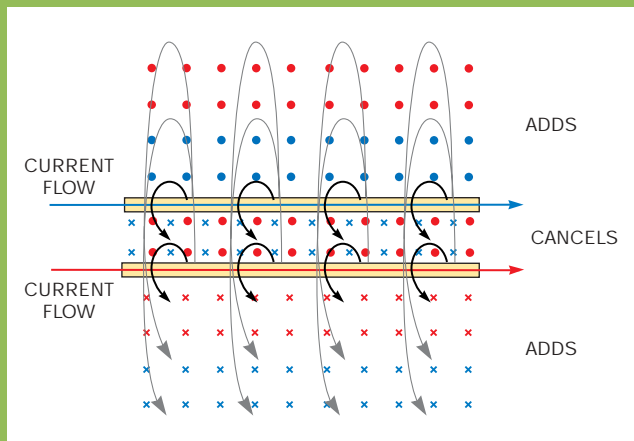

Figure B Wide pc-board traces have less inductance than narrow traces.

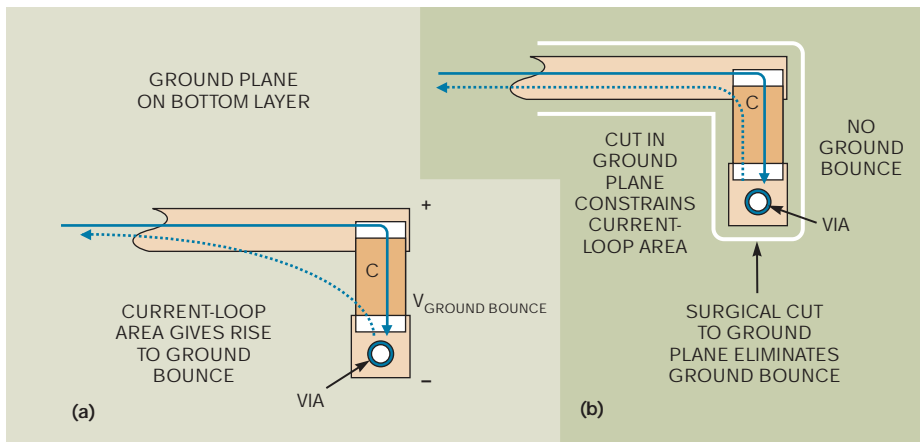

Figure 9 The ground plane is solid and uncut, and the top-trace current flows through the capacitor, down the via, and out the ground plane (a). A careful cut in the ground plane constrains the return current to a minimum-loop area and fixes the bounce (b).

voltage, and the ground bounces. Figure 9 provides an example in which a solid ground plane may be a poor choice. In this case, designers constructed a two-layer pc board so that a bypass capacitor attaches at a right angle to a top-layer supply line. In Figure 9a, the ground plane is solid and uncut, a common but sometimes poor layout practice. Top-trace current flows through the capacitor, down the via, and out the ground plane.

Because ac current always

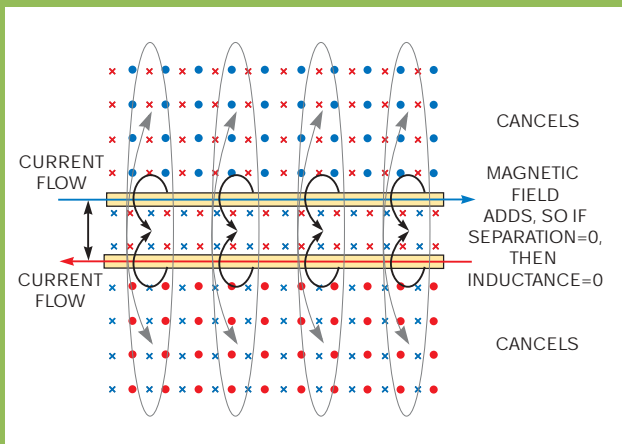

Figure C If the inside loop area is small, then the total magnetic flux and, therefore, the inductance will also be small.

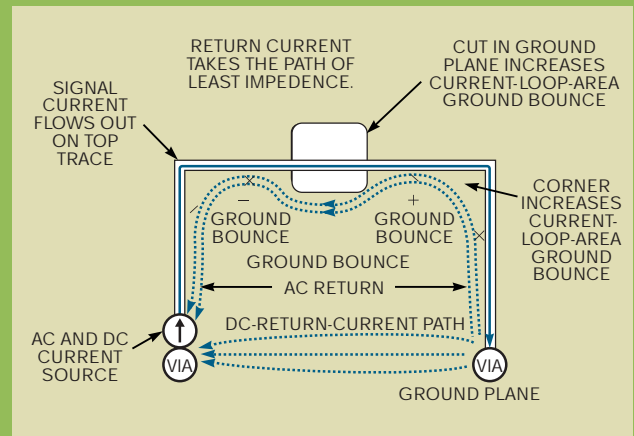

Figure E A current flows into a top trace, down a via, into a ground plane, and back up a via to the bottom of the source.

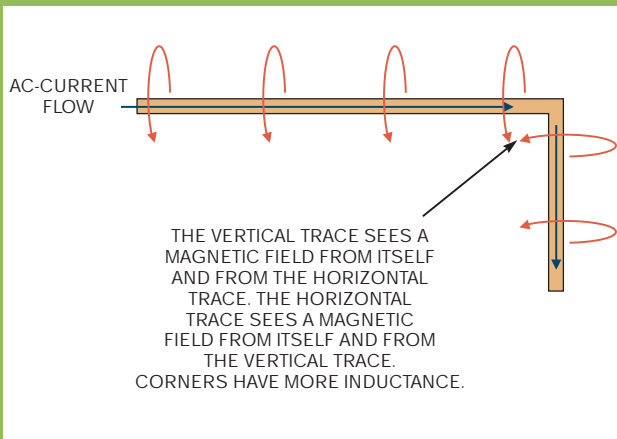

Figure D Both the vertical and horizontal traces see a magnetic field from themselves as well as from the perpendicular trace.

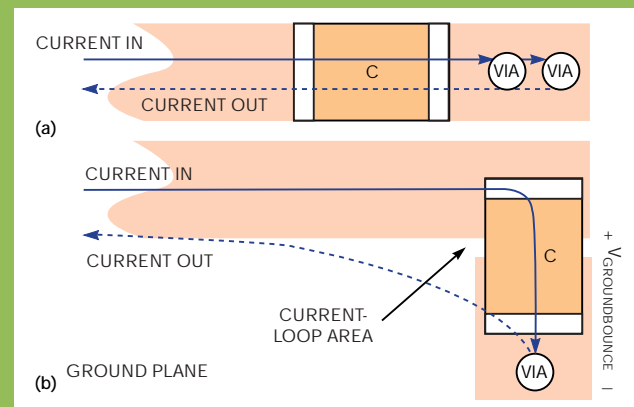

Figure F In good layout practice, the capacitor is in line with the current flow, creating a minimal loop size (a). Having the capacitor at right angles creates a large loop, causing ground bounce (b).

takes the path of least impedance, ground-return current cuts the corner on its way back to the source. But the current has a magnetic field and draws out a loop area that changes with a change in current magnitude or frequency. Magnetic flux is in that loop and changes if either the current magnitude or the frequency changes. That change means that a sheet ground plane—even if it's superconducting—can bounce. However, a careful cut in the ground plane constrains the return current to a minimum loop area and fixes the bounce. This approach also isolates the cut return line's bounce voltage from the general ground plane.

The pc-board layout in **Figure 10** uses the same principle as the one in **Figure 9** to reduce ground bounce. Designers built a two-layer pc board's input capacitor and both switches over an island in the ground plane. This layout is not necessarily the best, but it works well and illustrates the key principles. Note the large loop areas traced out by the red and blue current paths in **Figure 10**. But the two loops differ only slightly. The small change in loop area means a small change in magnetic flux and, hence, a small ground bounce. Additionally, in the ground-return island in which magnetic fields and loop area do change, the cut contains any ground-return bounce. Also, the input capacitor, C_{VIN} (**Figure 10**), may look as if it resides in a different area from the high-

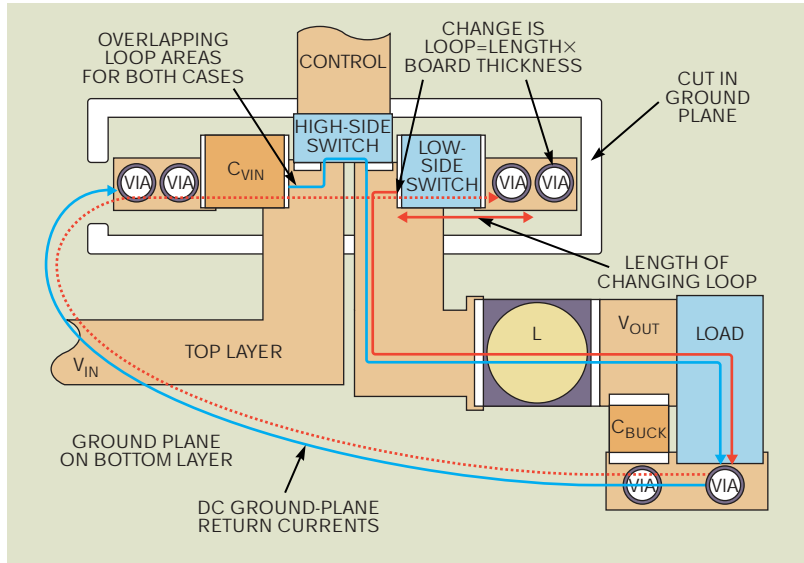

Figure 10 Designers built a two-layer pc board so that the input capacitor and both switches are over an island in the ground plane. Although the loop area by the red and blue currents is large, the difference between the two loops is small. The small change in loop area means a small change in magnetic flux and a correspondingly small ground bounce.

and low-side switches from C_{VIN} in **Figure 7**, but it is actually electrically nearby. Physical proximity can be good, but the electrical proximity that you achieve by minimizing the loop area is more important.

BOOST-CONVERTER GROUND BOUNCE

A boost converter is the inverse of a buck converter, so you must place the output capacitor so that it goes from the top of the high-side switch to the bottom of the low-side switch to minimize the change in loop area (**Figure 11**). Ground bounce results primarily from a change in magnetic flux, which induces a ground-bounce voltage. In a dc/dc-switching power supply, the flux changes because high-speed switches direct current to different current-loop areas. However, careful placement of the buck/boost-input/output capacitor and a surgical cut to a ground plane can isolate a ground bounce. Be careful when cutting a ground plane, because doing so can increase the loop area for some other return current in the circuit. EDN

MORE AT EDN.COM ▶

Go to www.edn.com/ms4193 and click on Feedback Loop to post a comment on this article.

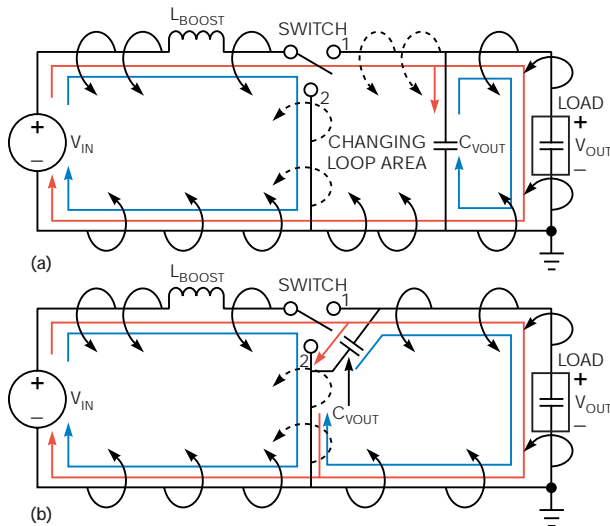

Figure 11 Unlike in a bad design (a), you must place the boost converter's output capacitor from the top of the high-side switch to the bottom of the low-side switch to minimize the change in loop area (b).

AUTHOR'S BIOGRAPHY

Jeff Barrow is a design manager for the Display Technology Products Group at Analog Devices (Tucson, AZ), where he is responsible for the development of multichannel power ICs and analog-signal conditioners for LCD TVs and monitors. He received a bachelor's degree in electrical engineering from the University of Arizona (Tucson), and his personal interests include physics and electronics.