

designideas

READERS SOLVE DESIGN PROBLEMS

Three microcontroller ports drive 12 LEDs

Nedjeljko Lekic and Zoran Mijanovic, University of Montenegro, Department of Electrical Engineering, Podgorica, Montenegro

Based on a previously published Design Idea (Reference 1), the circuit in Figure 1 uses only three I/O lines to drive 12 LEDs. In this application, the circuit serves as a tachometer for a motor-vehicle engine and displays relative engine speed on an array of LEDs arranged in a line or a circular arc. Three pairs of inverse-parallel-connected LEDs (D_2 and D_3 , D_4 and D_5 , and D_6 and D_7) receive drive current from IC_1 's ports through current-limiting resistors R_5 , R_6 , and R_7 . Two groups of

three LEDs, D_8 , D_9 , and D_{10} and D_{11} , D_{12} , and D_{13} connect among IC_1 's ports and two voltage dividers that supply reference voltages V_{REF1} and V_{REF2} . Varying the values of resistors R_5 , R_6 , and R_7 adjusts the brightness of the middle six LEDs, and R_1 , R_2 , and R_4 control the brightness of the outer six LEDs. In general, this circuit can use N of a host microprocessor's I/O lines to drive as many as $N(N-1)+2N$ LEDs, or $2N$ more LEDs than the circuit in the original Design Idea could drive.

DIs Inside

70 Magnetic-field probe requires few components

72 Dynamic siphon steals current from USB port

► What are your design problems and solutions? Publish them here and receive \$150! Send your Design Ideas to edndesignideas@reedbusiness.com.

The circuit uses Microchip's (www.microchip.com) PIC10F200 microcontroller, IC_1 , a small, inexpensive, six-pin device that provides only three I/O pins and one input-only pin. The I/O pins—GP0, GP1, and GP2—drive a 12-LED bar graph comprising

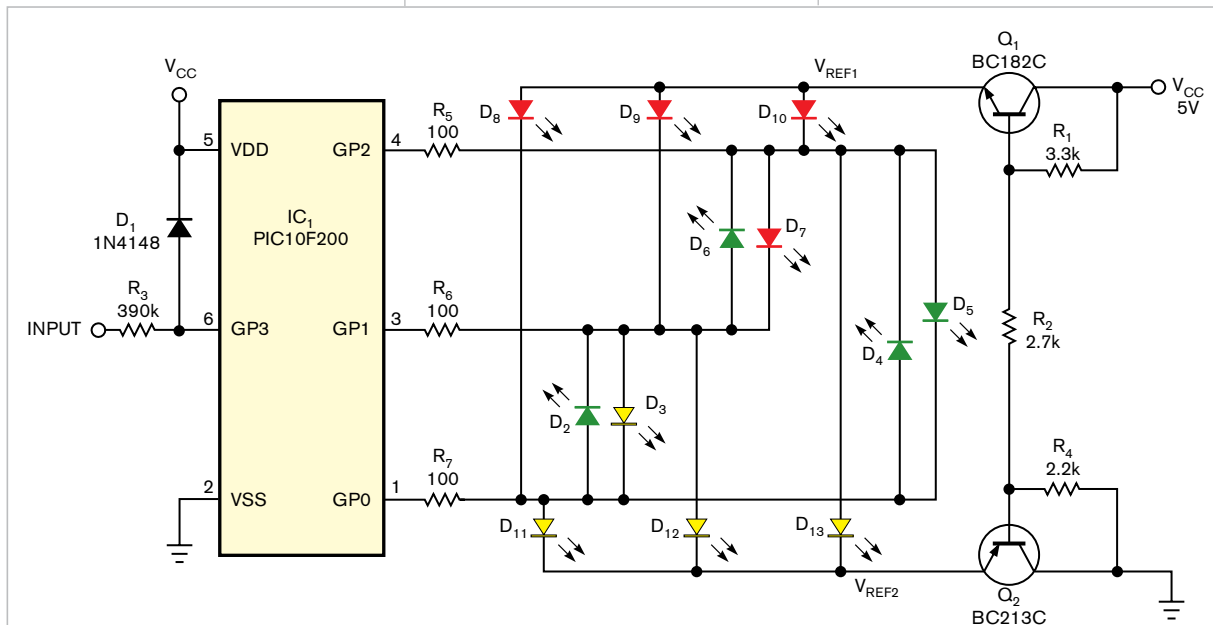

NOTE: LEDs ARE PANASONIC SSG LN224 SERIES (RED), LN324 SERIES (GREEN), AND LN424 SERIES (YELLOW).

Figure 1 A PIC microprocessor and a 12-LED bar-graph display form a simple tachometer circuit. (The decoupling capacitors are not shown.)

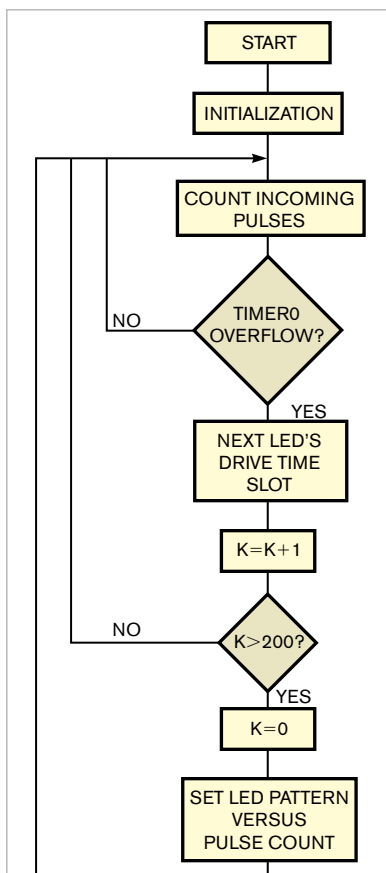

Figure 3. This flow chart shows the LED-driver software routine. (See the listings at www.edn.com/061215di1 for the complete tachometer routine.)

four yellow LEDs, four green LEDs, and four red LEDs driven in multiplexed mode (**Figure 2**).

The microprocessor's input-only pin, GP3, serves as the input for pulses coupled from the ignition coil's primary terminal. Resistor R_3 and diode D_1 provide input-signal conditioning, and a software-debouncing routine removes ringing effects from the pulses. Given R_3 's high value of 390 k Ω , the circuit tolerates high-voltage input spikes and prevents latch-up of the PIC10F200. Port GP3, which serves as the processor's programming port, differs from the processor's other ports because it incorporates an internal protection diode. The 20-mA diode prevents GP3 from negative-going transient voltages. The circuit oper-



Figure 2. The bar graph display's 12 LEDs can form a linear array or circular arc (not shown).

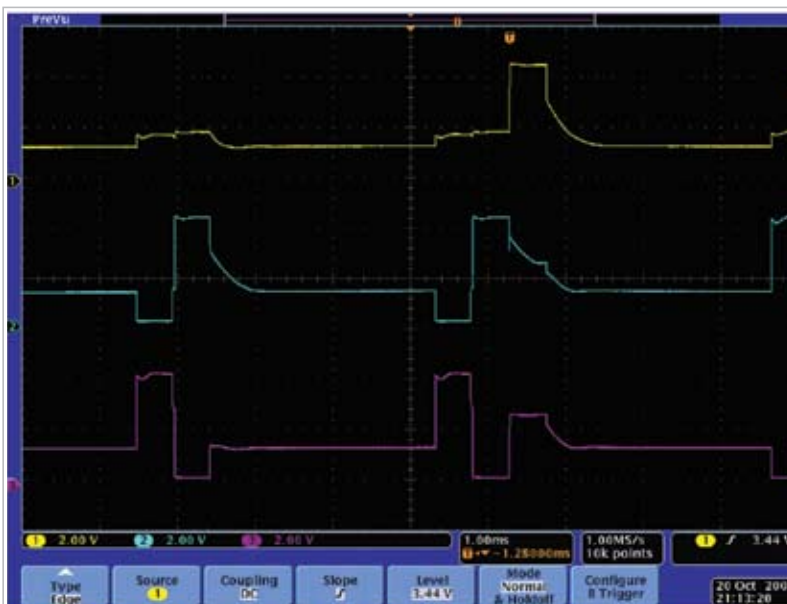

Figure 4 A digital oscilloscope captures the waveforms of GP0, GP1, and GP2 (upper to lower traces, respectively), which show a transition in the LED pattern from Case 7 to Case 8 (lines 62 and 63 in Listing `led121.c.pdf`).

ates reliably, but you can add an external protection diode for enhanced protection against transient-induced latch-up. Connect the diode's anode to ground and its cathode to pin GP3 of IC₁.

You can configure the bar graph to indicate engine speed by the number of LEDs turned on (bar mode) or by illuminating only one or two LEDs (dot mode). The color scheme in **Figure 2** uses yellow LEDs to indicate too-low speed, green LEDs for nominal speed, and red LEDs for excessive speed. **Figure 3** shows the indicator software's flow chart. The processor's internal clock drives Timer0 to overflow every 512 μ sec, which represents one time slot—that is, a multiplexing phase. Of eight time slots, one drives the three upper LEDs, and a second drives the three lower LEDs. For software simplicity, the last six time slots drive the middle

LEDs one by one. At the start of the main loop, the microprocessor counts clock pulses and waits for Timer0 to overflow. After overflow occurs, the output ports drive the LEDs according to their assigned time slots. After eight time slots elapse, the processor sets the ports to the same state. After 200 time slots, the processor counts incoming tachometer pulses and sets the LED pattern according to the incoming pulse count—that is, according to input frequency.

The tachometer indicates rotary speed as high as 120 cycles/sec. The accompanying software listings available at www.edn.com/061215di1 include files in C language (`led12.c.pdf`) and in assembly language (`led12.asm.pdf`). The source zip file contains a complete MPLab project. **Figure 4** shows the waveforms, which a digital oscilloscope captured at ports GP0, GP1, and GP2. **EDN**

Magnetic-field probe requires few components

Rama Sarma, EMI-EMC Centre, RCI, Hyderabad, India

Popularly known as “gauss meters,” various makes and models of magnetic field meters are available on the market at prices that make them unaffordable to many hobbyists and engineers. This Design Idea combines a commonly available DMM (digital multimeter) with a single semiconductor component to measure magnetic-flux density and, in turn, magnetic-field intensity.

Figure 1 illustrates the measurement equipment, comprising a probe, its battery pack, and a DMM. The probe's active element consists of a linear Hall-effect sensor. Although virtually any linear Hall sensor will work in this application, this version of the probe uses an Allegro MicroSystems Inc (www.allegromicro.com) A1323 sensor, which produces a voltage proportional to an applied magnetic field (Reference 1). Operating from a power supply of 4.5 to 5.5V, the A1323's quiescent output voltage (zero-field output) rests at 50% of the supply voltage. Given its nominal sensitivity of 2.5 mV/gauss, the A1323 provides a full-scale range of 1800 gauss (4.5V/2.5 mV/gauss=1800 gauss) for a supply voltage of 4.5V.

Applying a magnetic field oriented south of the sensor's face increases the sensor's output voltage in proportion to the applied field perpendicular to the sensor's branded face, and applying a magnetic field north of the same face causes a proportional decrease in output voltage. For a supply of 4.5V, the sensor's quiescent output voltage of 2.25V can increase to 4.5V for a 900-gauss, due-south field or decrease to 0V for a 900-gauss, due-north field. Although the sensor can detect the intensity and polarity of a dc magnetic field, its ac-field bandwidth extends to 30 kHz.

The probe's breadboard version comprises a small piece of pc board of sufficient length to fit the operator's hand (Figure 2). The sensor's leads connect to a length of high-quality, three-conductor shielded cable and two 10-nF surface-mounted decoupling capacitors. The sensor's power supply comprises three series-connected, miniature, 1.5V batteries for a total of 4.5V. For

a larger full-scale-measurement range, use a 9V battery to feed a 5V regulator IC, such as a 7805 voltmeter and add an on/off switch if desired. Place the batteries near the meter. Otherwise, the batteries' steel cases will disturb the magnetic field under observation. Use 10-nF SMD capacitors to decouple the sensor's input and output pins. Although any DMM offering high dc accuracy and an ac bandwidth exceeding 50 kHz can display the sensor's output, a DMM with a RELΔ (“relative-difference-from-reference-reading”) function, such as a Fluke (www.fluke.com) model 187 DMM, eases measurement

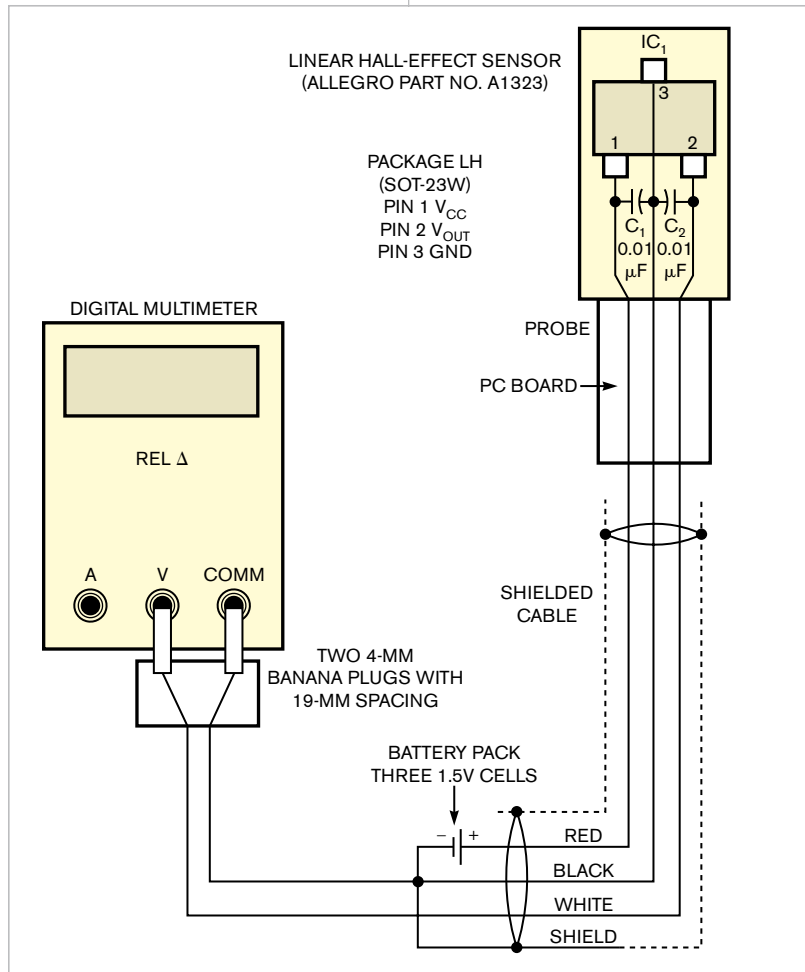

Figure 1 A digital multimeter and a Hall-effect sensor form an easily assembled magnetic-field probe.

and polarity detection of a dc magnetic field (**Reference 2**).

After assembling the circuit, connect the probe's output to the DMM using two 4-mm banana plugs. Allow a one-minute warm-up and place the probe's sensor in a magnetically shielded enclosure. (Editor's note: You can use salvaged steel, or "tin," concentrically fitting food cans to build a magnetically shielded enclosure. Arrange the cans so that their unopened ends point in opposite directions. Drill a small opening in the larger can's unopened end to accommodate the sensor's output cable.) Press the DMM's RELΔ function key. The DMM's display will show the sensor's quiescent voltage output of 2.25V as 0.0000V, indicating that the probe is calibrated for a zero magnetic field and ready for use.

Remove the probe from the shielded enclosure and measure the magnetic field under observation. To achieve maximum sensitivity, place the sensor's face perpendicular to the field. If the field's direction is unknown, rotate the probe about its longest axis to search for maximum voltage. To calculate the magnetic-flux density, divide the out-



Figure 2 The digital multimeter's relative-change mode (RELΔ) displays a near-zero magnetic field reading and the sensor's nominal zero-field output voltage of 2.25V.

put-voltage reading by the sensitivity (2.5 mV/gauss). For example, if the meter reads -1.9800V, then the magnetic field is 792 gauss due north. For an ac-magnetic-field measurement, use the DMM's true-rms mode to read the sensor's ac output voltage.

You can calculate a magnetic field's intensity in air by applying the follow-

ing formula: $B = \mu_0 \times H$, where B represents magnetic-flux density in teslas, H represents magnetic-field intensity in amperes per meter, and $\mu_0 = 4\pi \times 10^{-7} \text{H/m}$ (the permeability of free space). Given that the tesla represents a relatively large measurement unit, a 1T field is quite strong.

For greater measurement resolution, apply the following conversion factors to use the gauss, a more popular unit: 10,000 gauss=1T, 1 gauss=79.6 A/m, 1.2560 mT=1 kA/m. Applications for the magnetic-field sensor include troubleshooting moving-magnet linear-position detectors, fabrication of dc motors and audio speakers, investigation of low-frequency-magnetic-field interference, and designing and fabricating electromagnetic-interference shields.**EDN**

REFERENCES

- 1 A1323 Ratiometric Linear Hall-Effect Sensor Data Sheet, Allegro MicroSystems Inc, www.allegromicro.com/sf/1321.
- 2 *User's Manual, Model 187 & 189, True RMS Multimeter*, Fluke Corp, www.fluke.com.

Dynamic siphon steals current from USB port

Donald Schelle, Maxim Integrated Products Inc, Sunnyvale, CA

A USB port offers a handy source of 5V power for auxiliary devices. A USB port not only supplies power to a microcontroller and other essential circuitry, but also provides enough extra current head room to charge a small battery or supercapacitor energy-storage element. One typical approach to exploiting a USB port's leftover-current capability begins with an estimation of the essential circuitry's maximum current drain. You then place an appropriate current-limiting

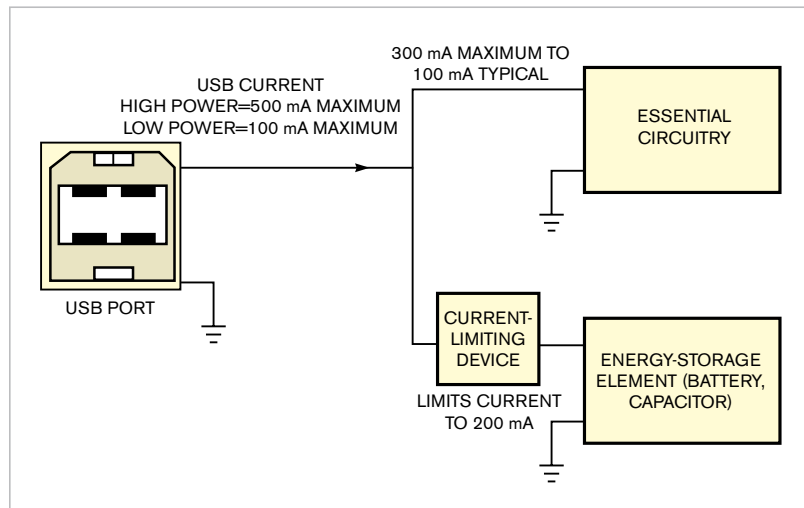

Figure 1 In this typical method for drawing power from a USB port, the storage-element current is limited to a fixed value that is less than optimal.

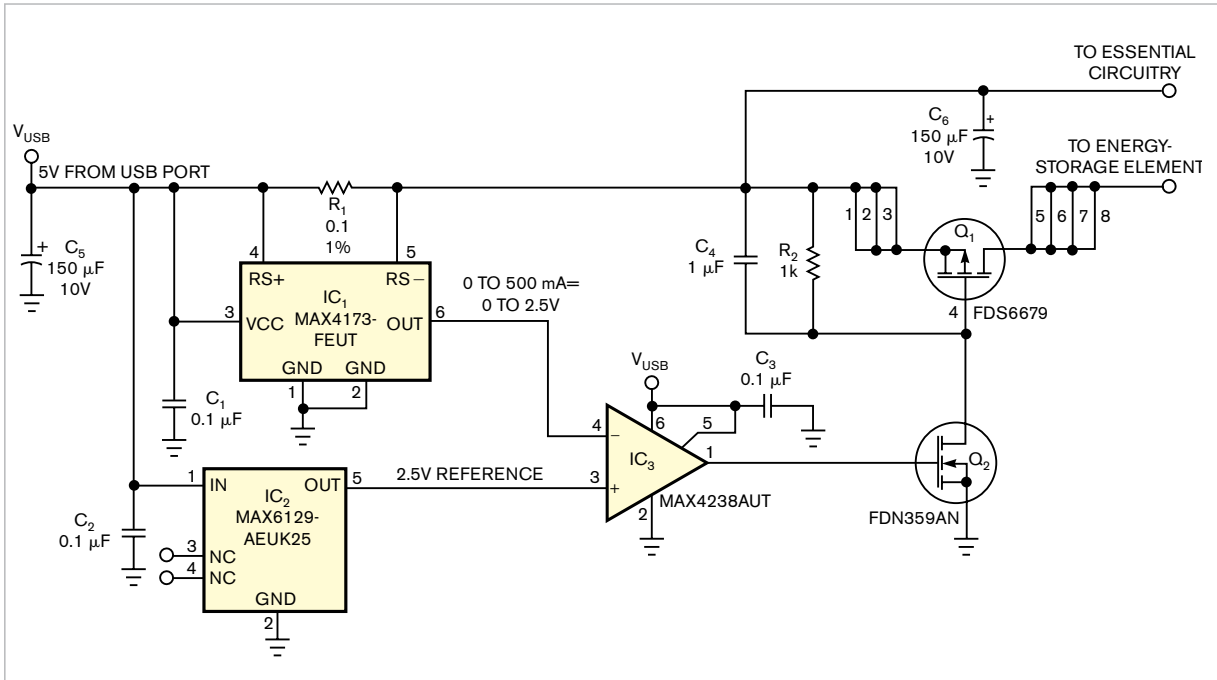

Figure 2 This circuit continuously monitors the total current drawn from the USB port and dynamically adjusts the storage-element current to avoid exceeding the port's maximum output capability.

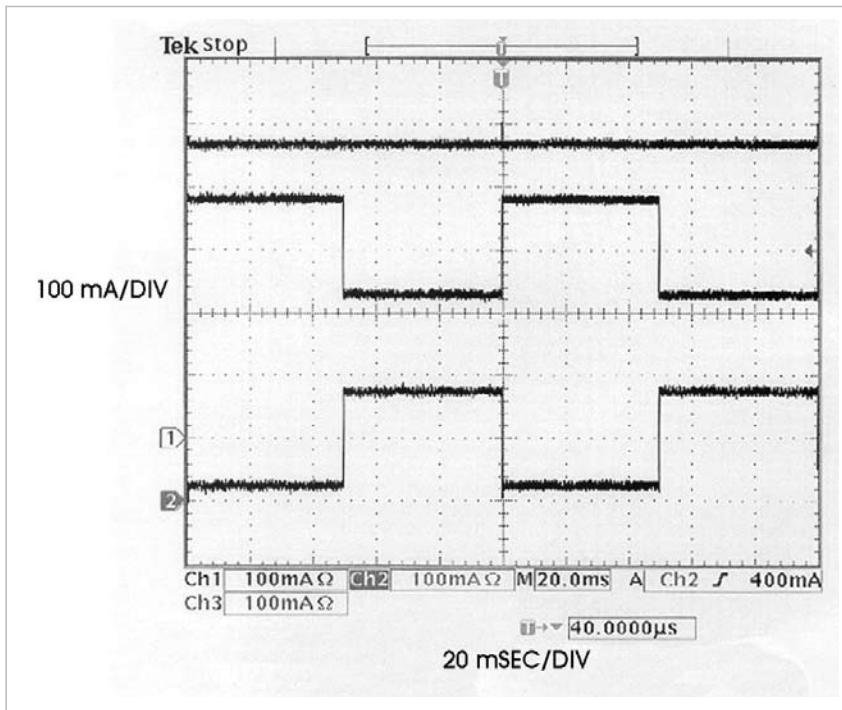

Figure 3 These waveforms taken from Figure 2 show that the sum of the essential-circuitry current (middle trace) and storage-element current (bottom trace) never exceeds the 500 mA maximum that the USB port (top trace) specifies.

device in the path of the energy-storage device (**Figure 1**). Although easy to implement, this method doesn't use all of the current available from the USB port, and the energy-storage device slowly charges or recharges.

The circuit in **Figure 2** uses all available USB power by dynamically adjusting the amount of current delivered to the energy-storage device and thereby siphoning a relatively constant and maximum current from the USB port. IC₁, a Maxim (www.maxim-ic) MAX4173FEUT; IC₂, a Maxim MAX6123AEUK25; and the load-switch circuit comprising Q₁, Q₂, R₂, and C₄ form a control loop that limits the current flowing through Q₁. The circuit maximizes current flowing to the energy-storage element (**Figure 3**) by ensuring that the sum of battery and essential-circuitry currents never exceeds the maximum of 500 mA for a high-power USB device. To reconfigure the circuit for low-power USB operation of 100 mA maximum, you can replace IC₁ with a MAX4173HEUT, a device with 100V/V gain, and R₁ with a 0.25Ω resistor. **EDN**