

designideas

READERS SOLVE DESIGN PROBLEMS

Simple fixture determines leakage of capacitors and semiconductor switches

Marián Štofka, Slovak University of Technology, Bratislava, Slovakia

The circuit in **Figure 1a** comprises a voltage follower, IC_1 , and the reference-voltage source of IC_2 . IC_1 is an Analog Devices (www.analog.com) AD8661 op amp, which has a guaranteed input-bias current of no more than 1 pA and a typical input-bias current of 0.3 pA (**Reference 1**), and IC_2 is an Analog Devices ADR391 precision voltage reference (**Reference 2**). The manufacturer trims the input offset voltage of this op amp not to exceed 100 μ V, and the typical value is 30 μ V. These properties suit this amplifier for observing

self-discharging of almost any type of capacitor. The leakage currents of solid-tantalum capacitors and those having high-quality plastic dielectrics are well above the input-bias current of voltage follower IC_1 . The CUT (capacitor under test) initially charges to the reference-voltage level of 2.5V by connecting Point A to the output of IC_2 . Subsequently, at some convenient time, Point A disconnects from the source of the reference voltage. A DVM (digital voltmeter) measures the output voltage of the follower at some reasonable time. The measured

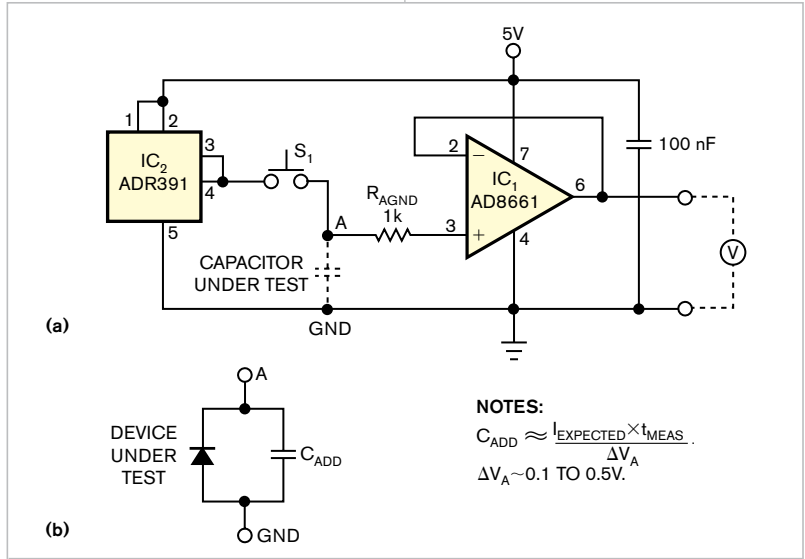

Figure 1 This simple fixture first impresses a reference voltage across a capacitor under test and then measures the voltage drop versus time at the output of the voltage follower (a). The circuit measures the leakage current of a reverse-biased active device (b).

DI Inside

84 Recycle precision potentiometers as useful voltage sources

88 Circuit breaker provides over-current and precise overvoltage protection

94 Paralleling decreases autozero-amplifier noise by a factor of two

94 Two transistors form high-precision, ac-mains ZCD

► **What are your design problems and solutions? Publish them here and receive \$150! Send your Design Ideas to edndesignideas@reedbusiness.com.**

voltage drop, V_O , with regard to initial value, should be 0.1 to 0.5V. The leakage current, I_O , is $C \times \Delta V_O / t_{MEAS}$, where C is the value of the CUT and t_{MEAS} is the time between releasing the connection of the CUT to the 2.5V source and the instant of readout at the voltage drop of V_O .

The fixture also allows determining leakage currents of reverse-polarized diodes and of various switching devices in the off state, such as JFETs, MOSFETs, BJTs (bipolar-junction transistors), SCRs (silicon-controlled rectifiers), and IGBTs (insulated-gate bipolar transistors). In this case, the parallel combination of the DUT (device under test) and the added capacitor, C_{ADD} , replaces the CUT (**Figure 1b**). The measurement and the formula for evaluating the value of leakage current are the same as those for leakage current in the equation $I_O = C \times \Delta V_O / t_{MEAS}$, but C_{ADD} substitutes for the CUT. A polystyrene-dielectric, 10-nF C_{ADD} works well for low-power devices. For high-power devices, however,

the value of C_{ADD} should be at least 10 times the value of the parasitic capacitance of the DUT at 0V.

Further, the fixture in **Figure 1b** can also determine the values of resistors of tens of megohms to about 2 T Ω . The current in the equation $I_O = C \times \Delta V_O / t_{MEAS}$, in this case, is the current flowing through resistor R_{AGND} at approximately the reference voltage. The resistance is roughly:

$$R_{AGND} \approx V_{REF} \times \frac{t_{MEAS}}{C_{ADD} \times \Delta V_O},$$

or, more precisely:

$$R_{AGND} = \left(\frac{V_{REF} - 1}{\Delta V_O - 2} \right) \frac{t_{MEAS}}{C_{ADD}}.$$

In all measurements, the voltage drop of V_O should not exceed about one-fifth of the reference-voltage value to allow approximating the inherently exponential droop of V_O by a linear decrease. The pushbutton switch in **Figure 1a**, S_1 , must exhibit a leakage of less than 1 pA. Stranded, isolated leads terminated with a gold-plated phosphorus-bronze pin can serve as a low-leakage switch. You can find gold-plated metal pieces in any type of high-quality connectors.

Also, you can clip the DUT or CUT between two gold-plated clips made of similar connector parts. To minimize the circuit's leakage, it uses no PCB (printed-circuit board). **EDN**

REFERENCES

- 1 AD8661 16V Low Cost, High Performance CMOS Rail-to-Rail Operational Amplifiers, www.analog.com/en/prod/0,2877,AD8661,00.html.
- 2 ADR391 2.5V Micropower, Low Noise Precision Voltage References with Shutdown, www.analog.com/en/prod/0,,769_838_adr391,00.html.

Recycle precision potentiometers as useful voltage sources

Mark Thoren, Linear Technology, Milpitas, CA

 An analog- or a mixed-signal lab cannot have too many voltage sources. A simple, reasonably high-precision voltage source can set bias points in an op-amp circuit, tweak the feedback node of a power supply through a large resistor, or run a quick linearity test on an ADC. Engineers often use a dc-power supply because it is the only thing they can find, and many labs lack a true voltage-calibration source. This Design Idea describes a circuit that recycles old precision potentiometers that have direct-reading scales into useful laboratory “volt boxes.”

Several types of potentiometers work in the circuit in **Figure 1**. Standard 10-turn potentiometers typically have 0.1% linearity and work well for general-purpose tweaking. However, a five-decade Kelvin-Varley divider with a total resistance of 100 k Ω or less achieves 10-ppm accuracy. Having some indication from a voltage source that its output is correct proves useful. A digital panel meter is one way of achieving this goal. However, even a 0.1% potentiometer is more accurate than most of these meters. So, to indicate that the output is correct, you need to know only whether the power is on, whether the supply voltage is

EDN tech clips



View a video presentation of this Design Idea.

www.edn.com/techclips

high enough, and whether the output amplifier is working properly and not sourcing or sinking too much current or oscillating.

A single red-green-blue LED provides all three indications. The green LED flashes at a low duty cycle when the power is on and stays lit continuously when the battery voltage is too low. The red LED illuminates when the output is out of regulation because IC_{4B} is a low-duty-cycle relaxation oscillator that pulses a green LED for 5 msec at approximately 0.5 Hz. The blue LED lights when sinking too much current. If the output is oscillating, the LED glows purple.

IC_{4A} compares the positive battery voltage to the precision 10V reference output and continuously turns on the green LED when the positive battery voltage drops below 11.5V. This level is the dropout voltage of the reference, so you know it's time to change the batteries. The load on the positive supply is greater than that on the negative supply, so these cells wear out first. And, because only two cells constitute the negative supply, battery wastage is minimal. Alternatively, you can move the negative cells to the positive side to squeeze the last bit of juice from them.

The reference is IC_1 , an LT1236-10 with an added trim circuit. The LT1236 is quiet and stable over time and temperature. Its output drives the top of the precision potentiometer or Kelvin-Varley divider. The output of the circuit is trimmed to 10V when the potentiometer or divider is at its maximum value. The two halves of an LT1881 amplifier, IC_{2A} and IC_{2B} , buffer the output of the potentiometer or divider. The combined bias current for both buffers is 400 pA maximum, which causes a change of approximately 10 μ V in the output voltage of a 100-k Ω potentiometer when it is at midscale. Make sure to properly guard the noninverting inputs to prevent leakage. The 50- μ V maximum offset and 130-dB CMRR (common-mode-rejection ratio) keep overall accuracy well within 10 ppm of a 10V total span.

One-half of the LT1881 is the voltage output of the volt box. The other half is necessary to drive the two inputs to IC₃, an LT1017 dual comparator that has an input-bias current of 15 nA per comparator. Q₁ to Q₆ form a 100- μ A current sink and source referred to the negative supply and positive supply, respectively. You adjust potentiometers R₁ and R₂ to set up a window around the output voltage that is compared with the output of IC_{2A},

which is a replica of the correct output voltage. If IC_{2B} is sourcing or sinking too much current, one of the comparators will trip, turning on the respective LED. If the output is oscillating, both LEDs will light. The window is adjustable from 0 to approximately ± 9.3 mV; ± 1 mV is a good place to start.

Should you need more output current than the 5 mA that the LT1881 guarantees, you can switch in an LT1010 buffer to provide a “turbo-

boost” feature, increasing the output-current capability to ± 150 mA and greatly increasing the ability to drive capacitive loads. You should normally disable this buffer because it draws 10 mA more from the supply. Switch S₃ allows reverse polarity, and, if you use a center-off switch, you can disconnect the output. S₁ is the power switch and can also select power from an external supply or battery power when isolation is critical. **EDN**

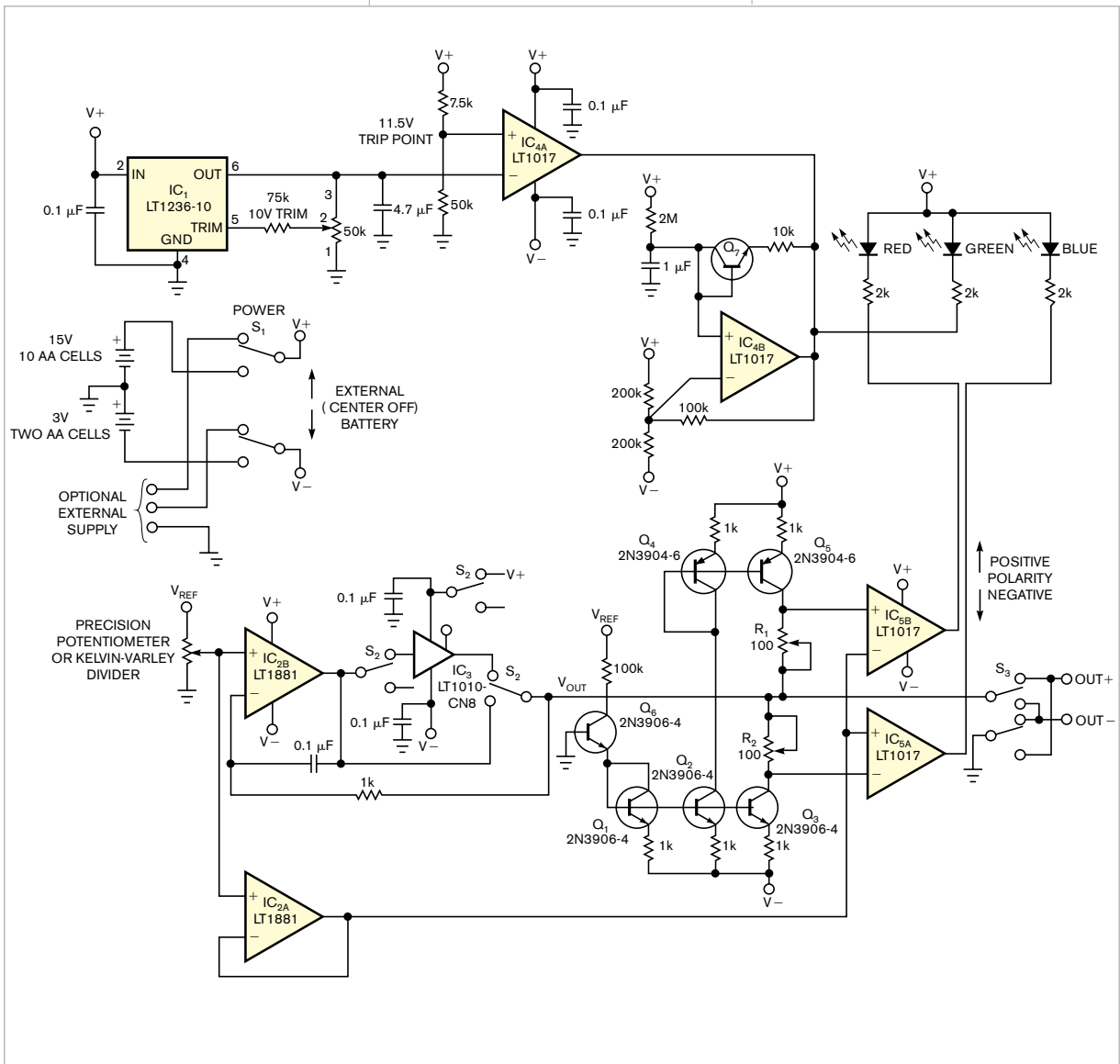

Figure 1 You can recycle old 10-turn potentiometers as precision “volt boxes.” The LEDs provide a visual indication that the output voltage is in regulation.

Circuit breaker provides overcurrent and precise overvoltage protection

Anthony H Smith, Scitech, Bedfordshire, England

Requiring only a handful of inexpensive components, the circuit breaker in **Figure 1** responds to both overcurrent- and overvoltage-fault conditions. At the heart of the circuit, D_2 , an adjustable, precision, shunt-voltage regulator, provides a voltage reference, comparator, and open-collector output, all integrated into a three-pin package.

Figure 2 shows a simplified view of the ZR431, D_1 . The voltage appearing at the reference input is compared with the internal voltage reference, V_{REF} nominally 2.5V. In the off state, when the reference voltage is 0V, the output transistor is off, and the cathode current is less than 0.1 μ A. As the reference voltage approaches V_{REF} the cathode current increases slightly; when the reference voltage exceeds the 2.5V threshold, the device fully switches on, and the cathode voltage falls to approximately 2V. In this condition, the impedance between the cathode and the supply voltage determines the cathode current; the cathode current can range from 50 μ A to 100 mA.

Under normal operating conditions, D_2 's output transistor is off, and the gate of P-channel MOSFET Q_4 goes through R_9 , such that the MOSFET is fully enhanced, allowing the load current, I_{LOAD} , to flow from the supply voltage, $-V_S$, through R_6 into the load. Q_2 and current-sense resistor R_6 monitor the magnitude of I_{LOAD} , where Q_2 's base-emitter voltage, V_{BE} , is $I_{LOAD} \times R_6$. For

normal values of I_{LOAD} , V_{BE} is less than the 0.6V necessary to bias Q_2 on, such that the transistor has no effect on the voltage at the junction of R_3 and R_4 . Because the input current at D_2 's reference input is less than 1 μ A, negligible voltage drops across R_5 , and the reference voltage is effectively equal to the voltage on R_4 .

In the event of an overload when I_{LOAD} exceeds its maximum permissible value, the increase in voltage across R_6 results in sufficient base-emitter voltage to turn on Q_2 . The voltage on R_4 and, hence, the reference voltage now pull up toward V_S , causing D_2 's cathode voltage to fall to approximately 2V. D_2 's output transistor now sinks current through R_7 and R_8 , thus biasing Q_3 on. Q_3 's gate voltage now effectively clamps to the supply voltage through Q_3 , and the MOSFET turns off. At the

same instant, Q_3 sources current into R_4 through D_1 , thereby pulling the voltage on R_4 to a diode drop below the supply voltage. Consequently, no load current flows through R_6 because Q_2 , whose base-emitter voltage is now 0V, has turned off. As a result, no load current flows through R_6 , D_2 's output transistor latches on, and the circuit remains in its tripped state in which the load current is 0A. When choosing a value for R_6 , ensure that Q_2 's base-emitter voltage is less than approximately 0.5V at the maximum permissible value of the load current.

As well as responding to overcurrent conditions, the circuit breaker also reacts to an abnormally large value of the supply voltage. When the load current lies within its normal range and Q_2 is off, the magnitude of the supply voltage and the values of R_3 and R_4 , which form a potential divider across the supply rails, determine the voltage at the reference input. In the event of an overvoltage at the supply voltage, the voltage on R_4 exceeds the 2.5V reference level, and D_2 's output transistor turns on. Once again, Q_3 turns

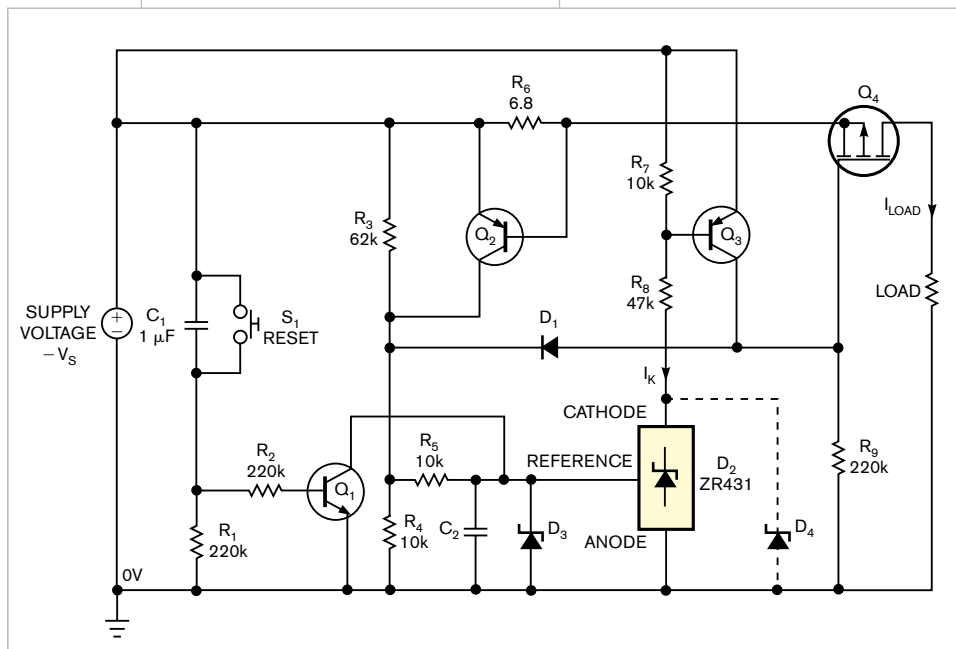

Figure 1 This circuit breaker provides both overvoltage and overcurrent protection. Other than the current flowing in R_3 , R_4 , and D_2 's cathode, the circuit draws no current from the supply in its normal untripped state.

on, MOSFET Q_4 switches off, and the load becomes effectively isolated from the dangerous transient.

The circuit now remains in its tripped state until reset. Under these conditions, Q_3 clamps Q_4 's gate-source voltage to roughly 0V, thereby protecting the MOSFET itself from excessive gate-source voltages. Ignoring the negligibly small voltage across R_5 , you can see that the reference voltage is $V_S \times R_4 / (R_3 + R_4)$ in volts. Because D_2 's output turns on when the reference voltage exceeds 2.5V, you can rearrange the equation as $R_3 = [(V_{ST}/2.5) - 1] \times R_4$ in ohms, where V_{ST} is the required supply-voltage trip level. For example, if R_4 has a value of 10 k Ω , a trip voltage of 18V would require R_3 to have a value of 62 k Ω . When choosing values for R_3 and R_4 to set the desired trip voltage, ensure that they are large enough that the potential divider will not excessively load the supply. Similarly, avoid values that could result in errors due to the reference-input current.

When you first apply power to the circuit, you'll find that capacitive, bulb-filament, motor, and similar loads having large inrush current can trip the circuit breaker, even though their normal, steady-state operating current is below the trip level that R_6 sets. One way to eliminate this problem is to add capacitor C_2 , which slows the rate of change of the voltage at the reference input. However, although simple, this approach has a serious disadvantage in that it slows the circuit's response time to a genuine overcurrent-fault condition.

Components C_1 , R_1 , R_2 , and Q_1 provide an alternative solution. On power-up, C_1 initially discharges, causing Q_1 to turn on, thereby clamping the reference input to 0V and preventing the inrush current from tripping the circuit. C_1 then charges through R_1 and R_2 until Q_1 eventually turns off, releasing the clamp at the reference input and allowing the circuit to respond rapidly to overcurrent transients. With the values of C_1 , R_1 , and R_2 , the circuit allows approximately 400 msec for the in-

rush current to subside. Selecting other values allows the circuit to accommodate any duration of inrush current you apply to a load. Once you trip the circuit breaker, you can reset it either by cycling the power or by pressing S_1 , the reset switch, which connects across C_1 . If your application requires no inrush protection, simply omit C_1 , R_1 , R_2 , and Q_1 and connect S_1 between the reference input and 0V.

When choosing components, make sure that all parts are properly rated for the voltage and current levels they will encounter. The bipolar transistors have no special requirements, although these transistors, especially Q_2 and Q_3 , should have high current gain, Q_4 should have low on-resistance, and Q_4 's maximum drain-to-source and gate-to-source voltages must be commensurate with the maximum value of supply voltage. You can use almost any small-signal diode for D_1 . As a precaution, it may be necessary to fit zener diodes D_3 and D_4 to protect D_2 if extremely large transient voltages are likely.

Although this circuit uses the 431 device, which is widely available from different manufacturers, for D_2 , not all of these parts behave in exactly the same way. For example, tests on a Texas Instruments (www.ti.com) TL431CLP and a Zetex (www.zetex.com) ZR431CL reveal that the cathode current is 0A for both devices when the reference voltage is 0V. However, grad-

ually increasing the reference voltage from 2.2 to 2.45V produces a change in cathode current ranging from 220 to 380 μ A for the TL431CLP and 23 to 28 μ A for the ZR431CL—roughly a factor of 10 difference between the two devices. You must take this difference in the magnitude of the cathode current into account when selecting values for R_7 and R_8 .

The type of device you use for D_2 and the values you select for R_7 and R_8 can also have an effect on response time. A test circuit with a TL431CLP, in which R_7 is 1 k Ω and R_8 is 4.7 k Ω , responds within 550 nsec to an overcurrent transient. Replacing the TL431CLP with a ZR431CL results in a response time of approximately 1 μ sec. Increasing R_7 and R_8 by an order of magnitude to 10 and 47 k Ω , respectively, produces a response time of 2.8 μ sec. Note that the relatively large cathode current of the TL431CLP requires correspondingly small values of R_7 and R_8 .

To set the overvoltage-trip level at 18V, R_3 and R_4 must have values of 62 and 10 k Ω , respectively. The test circuit then produces the following results: Using a TL431CLP for D_2 , the circuit trips at 17.94V, and, using a ZR431CL for D_2 , the trip level is 18.01V. Depending on Q_2 's base-emitter voltage, the overcurrent-detection mechanism is less precise than the overvoltage function. However, the overcurrent-detection accuracy greatly improves by replacing R_6 and Q_2 with a high-side current-sense amplifier that generates a ground-referred current proportional to load current. These devices are available from Linear Technology (www.linear.com), Maxim (www.maxim-ic.com), Texas Instruments, Zetex, and others.

The circuit breaker should prove useful in applications such as automotive systems that require overcurrent detection to protect against faulty loads and that also need overvoltage protection to shield sensitive circuitry from high-energy-load-dump transients. Other than the small current flowing in R_3 and R_4 and the current in D_2 's cathode, the circuit draws no current from the supply in its normal, untripped state. **EDN**

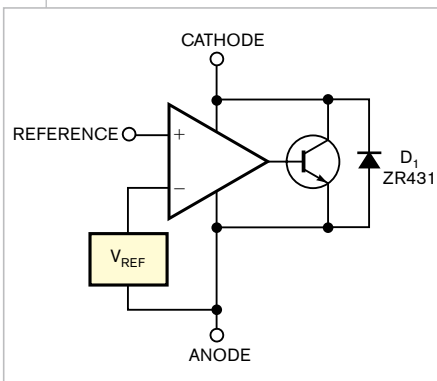

Figure 2 In this simplified view of the ZR431, the voltage at its reference input is compared with the internal voltage reference, which is nominally 2.5V.

Paralleling decreases autozero-amplifier noise by a factor of two

Marián Štofka, Slovak University of Technology, Bratislava, Slovakia

Autozero amplifiers have almost zero drift and input-offset values of 1 to 20 μV . You can compensate for the initial voltage offset of an autozero amp in sensitive circuits, such as dc amplifiers and integrators, requiring the

processing of voltages of 10 μV to 1 mV. Total compensation down to an offset of 0V, however, is an illusion because residual low-frequency output noise is still present in any autozero amp.

The Analog Devices (www.analog.com) AD8628 autozero amp has a low-frequency-noise value of 0.5 μV p-p at 0.1 to 10 Hz. If your application requires zero drift and low output noise, you can use the circuit in **Figure 1**. A quad autozero amp develops a gain of almost 1000. The resistor network comprising the R_3 resistors averages the output signals of these amplifiers to create the final output voltage.

The quad autozero amps are the four sections of IC₁, an Analog Devices AD8630 (**Reference 1**). Quad integrated resistors having one common lead can substitute for the four R_3 resistors. The R_1 and R_2 resistors should be high-

quality, precision, film devices with 0.5% or less tolerance. The tolerance of the R_3 resistors should not exceed 1%. The basis for decreasing the circuit's noise at the output in comparison with a single amplifier of IC₁ is the principle of averaging the signals containing the same deterministic component of random noise. If you assume that the amplifiers of IC₁ represent independent or uncorrelated noise sources that obey the gaussian distribution, then the standard deviation of the average of noise outputs of these sections is:

$$\sigma_{\text{AVE2}} = \frac{\sqrt{\sigma_X^2 + \sigma_Y^2}}{2},$$

where σ_X and σ_Y are the standard deviations of noise signals at outputs of the single respective amplifiers. If $\sigma_X = \sigma_Y$ —an assumption that you can make without hesitation because the op amps reside in one chip—then:

$$\sigma_{\text{AVE2}} = \frac{\sigma_X}{\sqrt{2}}.$$

If you average four amplifiers, you obtain:

$$\sigma_{\text{AVE4}} = \frac{\sigma_X}{2}.$$

If the value of output resistance of the circuit, which is about $R_3/4 \approx 38\Omega$, is too high for your application, place a voltage follower between the output terminal and the next stage.**EDN**

REFERENCE

1 "AD8630 Quad, Zero Drift, Single-Supply, Rail-to-Rail Operational Amplifier," Analog Devices Inc, www.analog.com/en/prod/0,2877,AD8630,00.html.

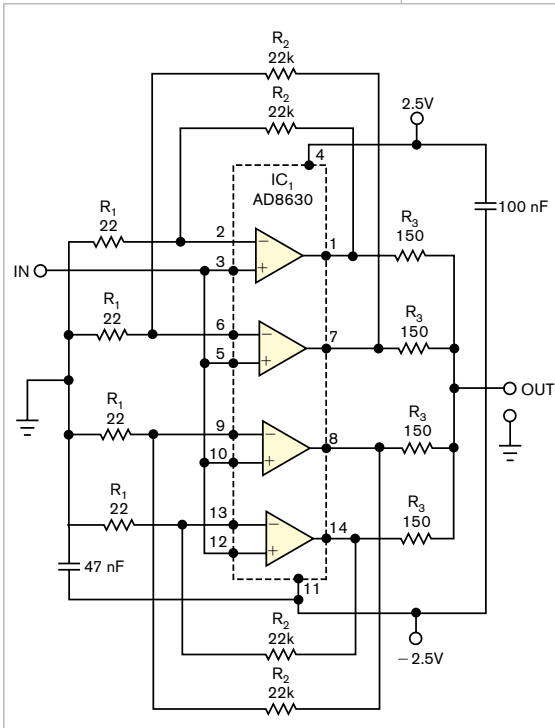

Figure 1 Use this circuit when your application requires zero drift and low output noise.

Two transistors form high-precision, ac-mains ZCD

Djessas Zoheir, Constantine, Algeria

Many applications that use 110V/230V-ac mains require a ZCD (zero-crossing-detection) circuit for the ac-line voltage, for example, to synchronize the switching of loads. One method of ZCD uses a high-value current-limiting resistor or a voltage-

resistive divider to sense the ac voltage at the controller's I/O pin. However, depending on whether the I/O pin is in TTL or Schmitt-trigger mode, the ZCD has a delay that depends on the threshold swing of the I/O pin and the slew rate of the power line. For example, as-

sume a 230V, 50-Hz ac system voltage and a voltage divider of 100—that is, 230V/100=2.3V. Further, assume that the I/O pin triggers at 1V. This trigger level implies 1V×100=100V referenced to the 230V-ac mains. Thus, 100=230×sin(2×π×50×t) yields a delay of 1.43 msec, which represents 14.3% of the half-cycle period—a significant error.

Figure 1 shows a low-cost, efficient ZCD using two standard transistors. Coming directly from the ac mains,

the supply network comprising C_1 , C_2 , D_1 , D_2 , and R_1 forms a simple half-wave rectifier, which powers the ZCD. Q_1 toggles with the ac-mains-voltage ZCD. To compensate for the base-emitter gap, Q_2 acts as a diode to block the ac-positive cycle. For efficiency, the detector must sense the ac-mains cycles at as high a voltage as possible. This requirement drives the choice of the transistor. Q_2 and Q_1 , low-noise, small-signal BC549B transistors, have collector-to-emitter-voltage limits of 30V. With this choice, you must attenuate the ac-mains voltage from 230 to 30V. (For a BC546 transistor, you can attenuate 230 to 80V.) Thus, the voltage-divider ratio is $30V/230V=13.4\%$, and the values of the divider resistors are $R_2/(R_3+R_2)=13.4/100$, or $R_3=6.46\times R_2$. R_2 and R_3 must be high enough for current limiting. The normalized value of R_3 , 820 k Ω , means that R_2 is 820 k $\Omega/6.46=126.9$ k Ω or 120 k Ω , the nearest standard-value resistor. With these values, Q_2 can block $230V\times R_2/(R_2+R_3)=29.3V$, which is

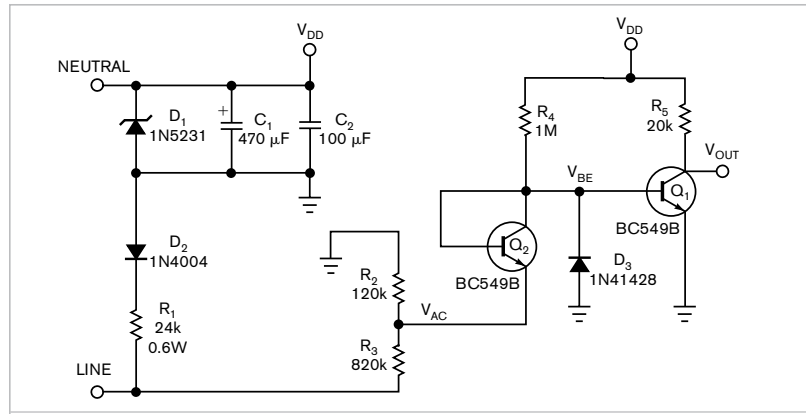

Figure 1 This simple two-transistor circuit accurately detects the zero crossing of the input ac mains.

less than the transistor's maximum rating of 30V.

Upon the ac-positive cycle, the base of Q_1 rises to approximately 0.6V through R_4 . Q_2 acts as a simple diode. So, when the cycle voltage is higher than 0V, Q_2 is reverse-biased and blocks any current flow. At 0V, Q_2 is forward-biased, but it maintains 0.6V across the base-emitter junction, V_{BE} . Thus, the collector, or base, of Q_2 , which connects to the base of Q_1 , stays at 0.6V. Q_1

is saturated for the positive cycle, and the output voltage is low. At the ac's negative cycle, when the ac voltage is less than 0V, current flows through Q_2 . Consequently, the base of Q_1 , which connects to Q_2 's collector, falls to less than 0.6V, which leads to the blocking of Q_1 and the output voltage's becoming high. Note that the base of Q_1 can reach about $-30V$ from Q_2 ; you can add clamp diode D_3 for Q_1 junction protection higher than $-1V$. **EDN**