



BY BONNIE BAKER



How the SNRs of delta-sigma converters differ

When I was a child, my parents bought me a 1-in.-diameter box turtle. I was so excited! To protect the turtle, I was going to put it in my block wagon. This wagon had slots to insert square, triangular, and round pegs. When my mom saw me grab a hammer, she knew it wouldn't be a pretty picture. "You can't fit a square peg—or a turtle—into a round hole," she told me.

That lesson also applies to the basic concept underlying delta-sigma modulators and ADCs—a concept that has been around since the 1930s. This converter topology is a bit different from other topologies; however, many engineers still strive to fit this converter into the standard ADC square hole.

Delta-sigma converters go beyond performing a simple analog-to-digital conversion. They have an oversampling mechanism, a modulator, and a digital filter. The oversampling mechanism spreads the noise power across a wider frequency range. The modulator shapes the low-frequency noise or pushes it out to higher frequencies. The digital filter averages the noise and eliminates it in the higher frequencies. The ideal successive-approximation-register and pipeline SNR (signal-to-noise ratio) is $6.02N+1.76$ (Reference 1), where N is the number of converter bits. The delta-sigma-converter SNR is $6.02(N+N_{INC})+1.76$, where N is the number of modulator bits and N_{INC} , the increase in resolution, is:

$$\frac{1}{6.02} \left[(20M+10)\log_{10} K - 20\log_{10} \left(\frac{\pi^M}{\sqrt{2M+1}} \right) \right]$$

In this formula, M is the order of the modulator, and K is the oversam-

Many engineers still strive to fit this [delta-sigma] converter into the standard ADC square hole.

pling ratio during the conversion.

Ideally, the delta-sigma-converter SNR, with a first order modulator, is $6.02N+1.76-5.17+30\log_{10}OSR$ where OSR is the oversampling rate and N is the number of modulator bits—not converter bits (Figure 1).

These ideal formulas assume that

the linearity, noise, and offset errors of the ADC and DAC—usually, 1-bit devices—are ideal and that the digital filter has an ideal brick-wall response. Actual delta-sigma converters are not as ideal as you would hope.

With these theories of the ideal, the best approach is still to rely on bench data for your converter performance. This data gives you a realistic view of the converter's capabilities. On the bench, you can measure your converter's rms noise by acquiring a few hundred samples of a dc-input signal. In this circumstance, the formula that describes any ADC SNR is $20\log_{10}(V_{RMS-FS}/V_{RMS-NOISE})$.^{EDN}

REFERENCES

- 1 Baker, Bonnie, "Where did all the bits go?" *EDN*, June 7, 2007, pg 36, www.edn.com/article/CA6447221.
- 2 Baker, RJ, *CMOS Mixed-Signal Circuit Design*, Wiley-IEEE Press, 2002.
- 3 Norsworthy, Steven R, Richard Schreier, and Gabor C Temes, *Delta-Sigma Converters: Theory, Design, and Simulation*, Wiley-IEEE Press, 1996.

Bonnie Baker is a senior applications engineer at Texas Instruments and author of *A Baker's Dozen: Real Analog Solutions for Digital Designers*. You can reach her at bonnie@ti.com.

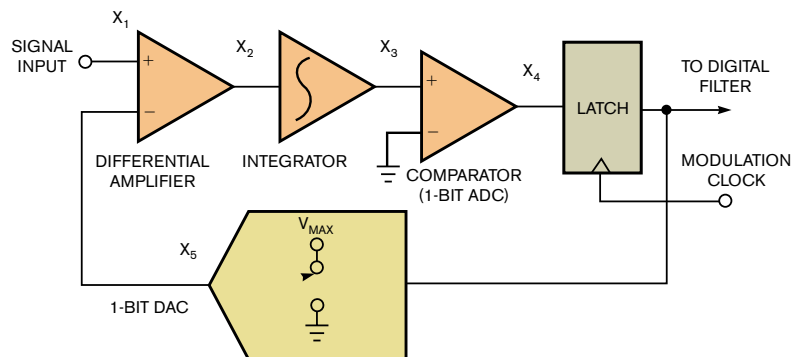

Figure 1 With a first-order modulator at the input of a delta-sigma converter, the ideal SNR is $6.02N+1.76-5.17+30\log_{10}OSR$.