



Figure 1 The Adlink PCI-8174 is an off-the-shelf stepper and servo controller for multi-axis, time-critical motion sequences.

AS NEW DESIGNS COMBINE ELECTRONIC CIRCUITRY, MECHANICAL ACTUATORS, AND MICROPROCESSOR SOFTWARE, A GROWING PERCENTAGE OF EMBEDDED DEVELOPMENT FALLS UNDER THE RECENTLY REVIVED "MECHATRONICS" MONIKER.

BY WARREN WEBB • TECHNICAL EDITOR

MECHATRONICS-BASED embedded design

With fully interactive products now the norm, mechanical-control circuitry has emerged as an integral part of embedded-system design. Although designers have since the early days of electronics used electromagnetic-control circuits to energize motors, relays, solenoids, and speakers, today's "smarter" motion-control components replace traditional mechanical elements with microcontroller-based circuitry to improve accuracies and coordinate movements. This trend brings traditional embedded-system design close to the newly coined "mechatronics" methodology, which combines mechanical, electrical, control-system, and embedded-software design.

Engineers at the Japanese company Yaskawa conceived the term "mechatronics" almost 40 years ago, yet people have until recently rarely used the term. Although a simple electromechanical circuit might meet the broadest definition of mechatronics, proponents prefer to apply the term to projects requiring a much higher level combination of disciplines, including electrical-circuit design, computer-aided-machine design, digital-control systems, and real-time-computer software. This new interest has sparked a number of leading universi-

ties to offer course work and even engineering degrees in mechatronics methodology. For example, North Carolina State University and the University of North Carolina offer a joint curriculum leading to a bachelor's degree in engineering with a mechatronics concentration.

Mechatronics offers a system-level approach to system design that reduces product-development times and risk through the use of simulation, computer-aided design, virtual prototyping, and design-tool integration. Mechatronics techniques allow designers to accurately simulate the performance of a machine early in the design process to ensure that the machine meets requirements and customer expectations. Unlike traditional electromechanical-system development, the virtual-simulation objectives of mechatronics tools provide the potential for simultaneous development of mechanical, electrical, and software elements. Automatic tools on the horizon promise to extend the control-system design from mostly trial and error to optimization through simulation. Mechatronics does require a substantial learning curve and time investment in system modeling that most embedded motion-control projects would not otherwise require.

Engineers may employ advanced mechatronics techniques for complex designs; in these designs, multiple motors or actuators coordinate to control precise motion. However, the fundamental motion-control principles remain intact. For example, dc motors find wide use in applications requiring servo control of rotational speed or torque. The basic relationships are that motor speed is proportional to the applied voltage, and output torque is proportional to the current. The designer's task is to pick the operating speed and then provide enough drive current to match the required load torque. The control problem becomes more of a challenge when you must control the speed of the dc motor during operation. The most popular approach to efficient dc-motor operation is to apply a PWM (pulse-width-modulated) square wave with an on-to-off ratio corresponding to the desired speed. The motor acts as a lowpass filter to translate the PWM signal into an effective dc level. PWM-drive signals are popular because a microprocessor-based controller can easily generate them. Stepper motors are also popular embedded-motion-control devices because they move in discrete steps, provide accurate angular-position information, and are relatively easy to control. The rotor of a stepper motor is made of permanent magnets arranged in a series of poles that determine the step size. The stator includes multiple windings to create a magnetic field that interacts with the rotor's permanent magnets. As a sequence of pulses from a control circuit turns the stator windings on and off, the motor rotates forward or in reverse.

Mechanical add-ons are finding their way into many traditionally all-electronic embedded-system applications. For example, users often complain that touchscreens are more difficult to use than physical buttons because of the lack of tactile feedback. Designers have responded with audio and visual clues, but these clues alone do not match the positive feel of a mechanical pushbutton. Immersion provides a new alternative with its TouchSense system that promises to trans-

AT A GLANCE

- ▣ To provide a more realistic interaction with the user, embedded-system designers are adding controlled mechanical motion to their products.

- ▣ Emerging mechatronics tool sets promise to integrate the electrical, mechanical, control, and embedded-software disciplines.

- ▣ Mechatronics tools allow designers to simulate the performance of a machine early in the design process to verify requirements.

- ▣ Product modeling and virtual prototyping shorten design cycles because electrical, mechanical, and software teams can work in parallel.

- ▣ Off-the-shelf motion-control boards and development kits provide an easy way to integrate mechanical devices with embedded-system applications.

form conventional, passive touchscreens into active displays with graphical buttons that press and release like pushbuttons. The TouchSense system supplies fast tactile response synchronized with sound and graphical image changes and does not affect touchscreen performance. You can add it to flat touchscreens as large as 6 in. diagonal and apply it to most touchscreen-sensing technologies, including capacitive, resistive, surface acoustic wave, and infrared. A software tactile-effect library controls a small electromechanical actuator, like the vibrator in mobile phones, which provides the physical movement.

To support the growing popularity of embedded systems with mechanical

components, a wide range of board-level manufacturers offer off-the-shelf, plug-in motion-control boards for standards such as PCI, CompactPCI, PC/104, and VMEbus. These boards allow designers to add motion control to a PC or an embedded system without digging into the details of controller design or feedback-loop optimization. For example, the Adlink Technology PCI-8174 low-cost stepper- and servo-motion-control card for the PCI bus offers an onboard DSP for simplified implementation of time-critical motion sequences (**Figure 1**). This board finds use in applications such as semiconductor-manufacturing equipment, electronic assembly, optical-inspection equipment, vehicle simulators, and precision carving machinery. The multi-axis-operation design of the PCI-8174 allows linear interpolation using all four axes and circular interpolation using any two axes. With the DSP onboard design, the PCI-8174 can also support firmware customization. The PCI-8174 is available now at prices starting at \$1190.

CONTROL KITS

If the objective is to rapidly integrate motion into an embedded product, the easiest way to get started is with an off-the-shelf development kit. For example, the MCK2812 DSP motion-control kit from Technosoft is a popular evaluation platform for investigating both the hardware and the software aspects of dc motors. This kit includes a Texas Instruments TMS320LF2812 DSP, 128k words of program RAM, and a serial-communications interface, all on a small PCB (printed-circuit board). The kit also includes an inverter power module and a brushless motor equipped with Hall sensors and a 500-line encoder for direct experimentation. All communication between the host PC and the DSP board is through a flash-resident communication monitor with downloading, debugging, and inspection functions. It includes a set of ready-to-run examples with assembly source code. The kit also features the DMCD (Digital Motion Control Development) software platform with an in-

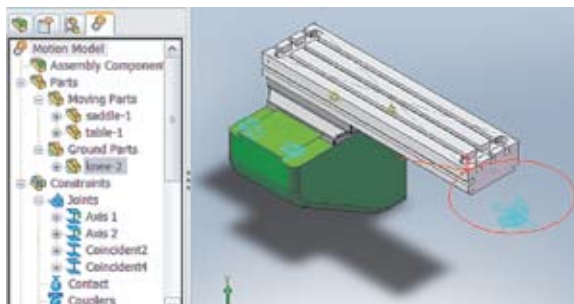

Figure 2 National Instruments' LabView and SolidWorks' CosmosMotion provide a closed-loop simulation of the dynamics of an electromechanical system.

egrated debugger, a basic assembler, a linker, and other facilities that allow you to create, modify, and test assembler applications within a project-management system. The MCK2812 DSP motion-control kit costs \$3290 and is available directly from Technosoft.

Mechatronics engineers often determine operational behavior and uncover system shortcomings by detailed, up-front modeling and simulation of proposed designs. Engineers can exercise an accurate system model before the availability of physical hardware to determine whether the system meets specifications and customer expectations. Unfortunately, the required modeling process is unduly complicated when mechanical and electrical elements coexist. One solution to this problem is to extend a modeling language to cover hybrid systems. The IEEE took this approach by extending the VHDL (very-high-level hardware-description language) with AMS (analog/mixed-signal) extensions. The IEEE built the language, informally known as VHDL-AMS, on the IEEE Standard 1076-1993 language, and it allows designers to develop and simulate analog and mixed-signal models.

Mentor Graphics' SystemVision development tool uses the VHDL-AMS language as its foundation to describe the behavior of hybrid hardware technologies typically in embedded mechatronic systems (**Reference 1**). These systems contain a combination of analog, digital, and electromechanical components, each requiring significantly different modeling techniques. SystemVision allows designers to include components of different levels of abstraction within the same system model to focus on the details of a part of the system and maintain its context within the overall system design. Designers can use VHDL-

THE REQUIRED MODELING PROCESS IS UNDULY COMPLICATED WHEN MECHANICAL AND ELECTRICAL ELEMENTS COEXIST.

AMS signal-flow models in high-level block diagrams, and, as the design progresses, they can incorporate physical-hardware models into the system model to successively verify proper system performance. They can use algebraic or differential equations to describe a system model that incorporates a combination of various technologies, such as mechanical, magnetic, hydraulic, or thermal effects. For example, designers can use a three-phase design tool from Infolytica to create a VHDL-AMS model of an automotive alternator.

HYBRID SIMULATION

National Instruments and SolidWorks have teamed up to bring electrical and mechanical modeling and simulation to mechatronics designers on a grand scale. The alpha version of their recently released Mechatronics Toolkit allows designers to simulate the integrated mechanical and control design in software before moving to the prototype and production stages. Designers can simulate mechanical dynamics, including mass and friction effects, cycle times, and individual component performance before specifying a single physical part. They can tune and customize control-system and feedback elements entirely through the software model. They can test electrical performance and real-time response times at operational extremes without stressing a part. When they move the design from prototyping to production, they can reuse the same software that they used for simulation.

The Mechatronics Toolkit integrates several graphical-design packages with software linkages to transfer parameters between the electrical and the mechanical environments. SolidWorks, a popular mechanical, 3-D-computer-aided-design program, includes tools for mechanical design, verification, motion

MORE AT EDN.COM

⊕ For more on managing motion, go to www.edn.com/article/CA231571.

⊕ For an article on model behavior and creating embedded-software shortcuts, go to www.edn.com/article/CA6406717.

⊕ Go to www.edn.com/071025df and click on Feedback Loop to post a comment on this article.

simulation, data management, and project communications. CosmosMotion, a SolidWorks add-on for virtual prototyping, uses mechanical dynamics to help simulate mechanism motion. National Instruments' LabView provides the tools for electrical and control-system design, simulation, and automatic code generation. This combination of LabView for a control-design environment and SolidWorks/CosmosMotion for a mechanical-design environment provides designers with a true closed-loop simulation of the dynamics of a mechanism and the controls that act on it (Figure 2). National Instruments offers a free mechatronics resource kit that demonstrates how these tools can integrate mechanical design, control design, simulation, sensing and actuation, signal processing, and electronic design (Reference 2).

All of these tools and techniques demonstrate an industrywide effort to improve electromechanical development by streamlining design, prototyping, and deployment. The latest mecha-

FOR MORE INFORMATION

Adlink Technology
www.adlinktech.com

IEEE
www.ieee.org

Immersion
www.immersion.com

Infolytica
www.infolytica.com

Mentor Graphics
www.mentor.com

National Instruments
www.ni.com

North Carolina State University
www.ncsu.edu

SolidWorks
www.solidworks.com

Technosoft
www.technosoftmotion.com

Texas Instruments
www.ti.com

University of North Carolina
www.unc.edu

Yaskawa Electric America
www.yaskawa.com

tronics technologies promise to deliver higher profits through low-risk, low-cost development and increased efficiency. To take advantage of these benefits, designers must adopt a new design strategy that relies on graphical modeling and system simulation. These tools have the potential to greatly shorten the development cycle and even to eliminate the need for some of the project engineers or software developers. The industry now has the graphical tools to model

a proposed system, automatically reconfigure an off-the-shelf FPGA with microprocessors and custom circuitry, optimize the mechanical control circuitry, and then synthesize the needed software. Maybe the next generation will eliminate the need for an engineering staff altogether. **EDN**

REFERENCES

- 1 Egel, Tom, "SystemVision for Embedded Mechatronic Systems: Hardware Modeling," Mentor Graphics Corp, www.mentor.com/products/sm/techpubs/mentorpaper_24263.cfm.
- 2 Mechatronics Resource Kit, National Instruments, <http://digital.ni.com/express.nsf/bycode/exg9gi>.

You can reach
Technical Editor
Warren Webb
at 1-858-513-3713
and wwebb@edn.com.

