

NOISE FROM CELL PHONES, DIGITAL OSCILLATORS, AND EVEN FLUORESCENT LIGHTS IS ASSAILING YOUR ELECTRONIC DESIGNS. LEARN WHAT CAUSES THIS NOISE AND WHAT YOU CAN DO TO INCREASE YOUR SYSTEM'S IMMUNITY TO RADIO-FREQUENCY INTERFERENCE.



RFI: KEEPING NOISE OUT OF YOUR DESIGNS

BY PAUL RAKO • TECHNICAL EDITOR

Steady streams of RF energy constantly engulf your electronic system. Some of this energy comes from the accidental byproduct of a system; other RF sources, such as radios and radar, intentionally radiate energy. Some RF sources are so strong and so insidious that they create noise in simple wires, such as the magnet wire that forms the voice coil of a speaker. It is merely annoying for consumers to hear noise in their home-audio systems. However, RF noise that causes a machine to go haywire or an airplane's instruments to malfunction could imperil or even kill people. For this reason, the European Union and the United States instituted RFI (radio-frequency-interference) testing for products that vendors sell there. When the European Union more

than a decade ago instituted the CE (Conformité Européenne) immunity-compliance tests, engineers soon learned that passing them is more difficult than passing the US FCC (Federal Communications Commission) noise-radiation tests. "Engineers don't think it is a problem until it is a problem for them," says Steve Bible, Microchip Technology's technical-staff engineer. "They are in a real time crunch. They have made a bad

design, and it's hard to convince them that it's bad. They want to find that one silver bullet—the one thing they can do so they can pass—except there is no silver bullet."

To provide your systems with robust RFI immunity, you must understand just how many RF sources your system is subject to. The electric-power industry broadcasts 50- or 60-Hz radio waves as it sends power to your house. Your watch

has a 32-kHz crystal that emits energy. Electronic ballasts for fluorescent lights operate at 40 kHz. Traffic lights use loop sensors that energize at 50 to 100 kHz. At higher frequencies, you soon encounter “intentional radiators,” which the FCC defines as radio stations; TV stations; and various private, public, and military radios, some of the most troublesome of which are cell phones. Radar systems and exotic military systems lie even beyond cell phones on the frequency spectrum. Cosmic rays also cause problems (Reference 1). It is difficult to help a customer with an RFI-susceptibility problem because hundreds of ways exist to hook up an amplifier in a signal path, according to Steve Sockolov, product-line director for Analog Devices’ precision-linear-products group. You also must worry about a continuum of source frequencies. To help customers with precision-measurement circuits, Analog Devices has developed the AD8556 sensor-signal amplifier, a functional equivalent of the AD8555 amplifier, except that the AD8556 has EMI (electromagnetic-interference) filters on the input pins, the reference pin, and the clamp pin. These filters help suppress RFI across a wide range of frequencies.

Not all RFI sources are causes for concern. The aforementioned watch crystal operates at a relatively low frequency and transmits minuscule power levels. Other sources may or may not be problematic. For example, you may use a FET as a low-side switch in a synchronous buck regulator. The FET’s package case connects to the switch node and swings the entire power-supply voltage (Figure 1). Because this node operates at the power-supply frequency, you would think that it would radiate RF energy, but it may not. To radiate RF, current must be flowing. By using the package pin to carry the current and using the package tab to absorb the heat of the circuit, a clever designer can cool the FET and minimize RF radiation.

One way to solve an immunity problem is to stop the RF

AT A GLANCE

- ▣ RF sources can transmit energy into cables, PCB (printed-circuit-board) traces, and ICs.
- ▣ Symptoms of RF susceptibility can be tricky to diagnose.
- ▣ The best technique is to kill noise at its source.
- ▣ Shielding is a high cost Band-Aid.
- ▣ Careful layout and good system design can provide the best protection from RFI (radio-frequency interference).

source. Automotive engineers decades ago learned this technique when they first installed radios into automobiles (see sidebar “Insidious RF” at the Web version of this article at www.edn.com/080110df). It soon became evident that barring noise from the radio was a difficult process, whereas killing the noise at its source was an effective technique. The engineers achieved this goal by

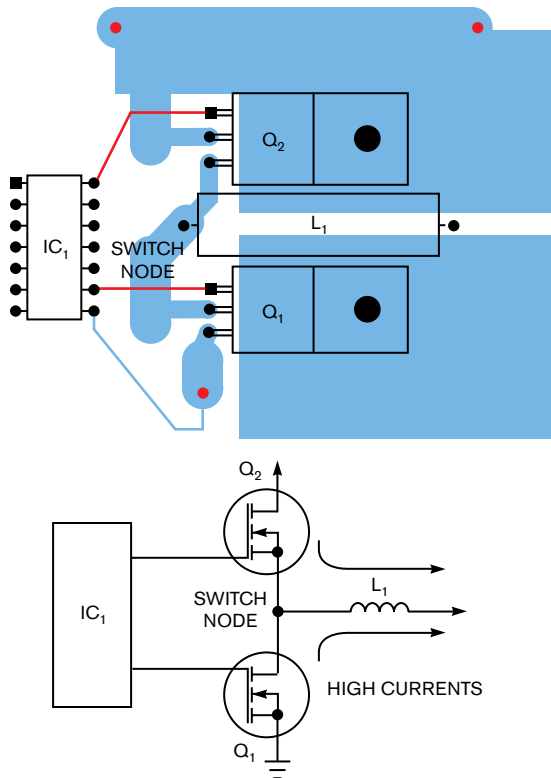

Figure 1 A copper pour forms a large heat sink that may look problematical from an EMI perspective. Because it carries no current, however, the heat sink does not radiate large amounts of RF energy.

adding capacitors to the alternator. The capacitors suppressed the diode-switching spikes, minimizing circulating currents and, thus, noise (Reference 2). The use of these techniques, along with tight layouts, will help you pass FCC radiation tests. Using these methods also subtracts one source of RFI that may cause immunity problems.

The biggest problem in RFI arises because you often have no control over the RF source that is polluting your system, such as the source you encounter in cell phones, which operate at high frequencies. This RFI can enter many parts of your design: the cables, the PCB (printed-circuit-board) traces, and even the ICs themselves. In addition, cell phones are everywhere, often sitting next to or atop your design while you are working on it. A few anecdotes tell the story: Bob Thomas, an engineer with Cisco Systems, reports that, when he sets his cell phone in the package tray of his 2006 Honda, the noise it radiates into the radio is louder than the music that the radio emits when it is on. Another Cisco engineer, Steve Abe, notes that placing his cell phone on his Palm Zire causes the Zire to reboot whenever he receives an incoming call. Francis Lau, an engineer with FM-transmitter manufacturer Aerielle, says that the stereo in his home makes a buzzing sound when he is about to get a call on his cell phone.

To understand why cell phones can be sources of RFI at audio frequencies, you must examine the RF-transmission protocols. The NADC (North American digital-cellular)-phone system uses the TDMA (time-division/multiple-access) protocol, which multiplexes digital-traffic channels—that is, voice data—into time slots. A sequence of six time slots makes up a 40-msec frame. In a full-rate traffic channel, a user transmits twice in each frame, meaning that a user assigned to the first time slot transmits again in the fourth time slot. By transmitting twice in each frame, the cell phone picks up EMI that looks like a square wave with a 20-msec, 50-Hz period (Figure 2).

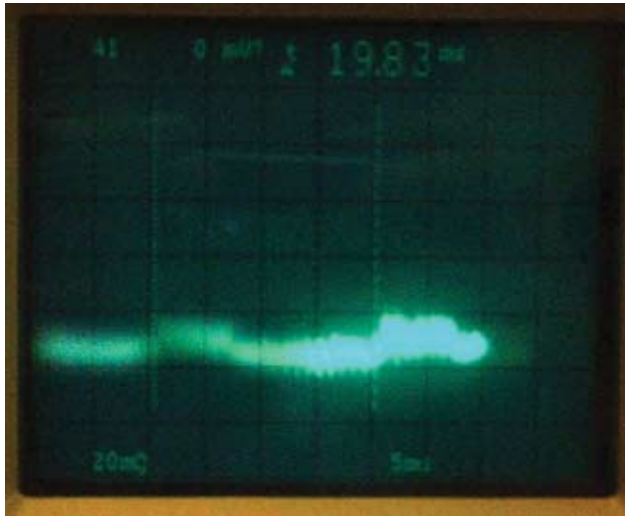

Figure 2 The TDMA phone standard uses radio protocols that result in bursts of RF at 50 Hz. You hear the demodulation of the signal envelope in stereos and clock radios.

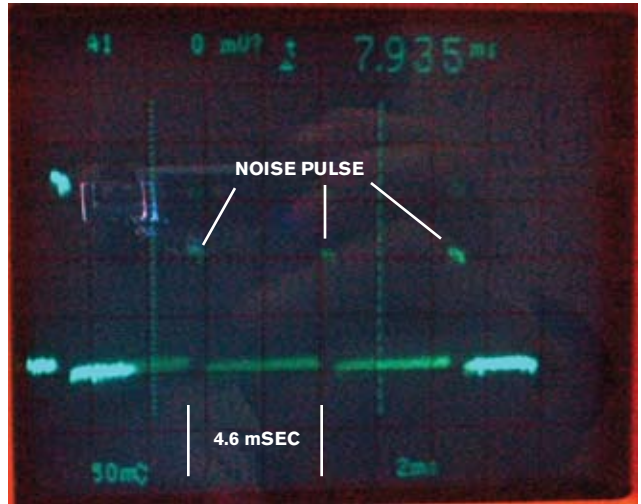

Figure 3 The GSM standard has a signal envelop with a 217-Hz frequency. Because power levels are higher and the human ear is more sensitive at 217 Hz, these phones can produce large interference problems.

In contrast, the GSM (global-system-for-mobile)-communication protocol specifies a 33-dBm transmission once every 4.6 msec, causing greater interference than the TDMA protocol, which transmits at 20 dBm (Figure 3). Figures 2 and 3 represent interference in a real-world system, and, in this case, the GSM interference is 100 mV versus 5 mV for the TDMA phone. The interference you hear in your car stereo and clock radios is not a 900-MHz burst but a repetitive envelope of those bursts that occur in ICs and even in wire due to the non-linearity in the system. RF consultant James Long advises that all electronic devices have a transfer function that is a power series of the input signal. That is, $V_{OUT} = V_{IN} \times k1 + V_{IN}^2 \times k2 + V_{IN}^3 \times k3$, a series that continues to infinity, with k representing a constant. As a result, many extra frequencies, including the demodulated baseband of the interfering signal, occur. Nonlinear circuits include those that depend on feedback to reduce distortion. At higher frequencies, the feedback effect is nonexistent, and the system does not suppress RFI (reference 3, 4, and 5).

Input-protection diodes and other junctions in analog ICs demodulate the frequencies that PCB traces and ground and power planes pick up, and this demodulated signal appears as audio-fre-

quency noise. At 1 GHz, the IC itself is not an effective antenna for typical RF emissions. The tiny bond wires and capacitances are more susceptible to frequencies in the tens of gigahertz, far above the excitation frequencies that cell phones cause. Different ICs of the same type or from different manufacturers behave differently, depending on variations in input capacitance or lead-frame inductance, but they are still susceptible to RFI. To combat the problem, National Semiconductor designed the LMV851 op amp to reject RFI. The company has devised the EMIRR (EMI-rejection-ratio) figure of merit that quantifies how well various pins of the IC reject RFI (Reference 6).

FET and CMOS op-amp input struc-

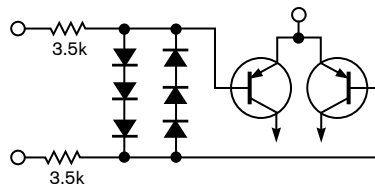

Figure 4 The input pins of this op amp have series resistors and large capacitive-clamp diodes to protect it from ESD. An added benefit is that the part is more immune to RFI (courtesy Maxim Integrated Products).

tures are less prone to demodulation effects than bipolar amplifiers are. Still, Kumen Blake, principal applications engineer at Microchip Technology, points out that CMOS parts can detect RF if you drive the inputs hard enough. “Even CMOS will reverse-bias and create a transistor junction [under RF radiation],” he says. “Any op amp can convert RF or microwave energy into a dc signal. Many customers don’t understand what symptoms they will see if they have an EMI problem. A dc shift can be a symptom. A change in power level means there’s a good chance that RFI caused some oscillation. Another symptom is distortion of the signal, whether the frequency changes or whether harmonic distortion appears. The worst symptom is erratic behavior: The circuit just does not work right all the time.”

Some ICs use the resistance of the input structure to decouple the RF from inside the amplifier. Even a small input resistance can work with the stray capacitance of the amplifier’s ESD (electrostatic-discharge)-protection diodes and other structures to effectively bypass the RF to ground. For example, Maxim uses this technique to provide ESD protection on the LMX324 op amp and to provide RFI immunity (Figure 4). The downside is that the resistors limit bandwidth and slightly reduce phase margin.



Figure 5 This copper-clad board has two antennas soldered to opposite sides of the same ground plane. When you operate circuits with fast edges on the board, the antennas radiate significant amounts of RF, even though they galvanically connect (courtesy Glen Dash).

A ground or power plane has more than enough impedance to cause RFI reception or transmission through the wires that attach to the plane. You cannot assume that a 20×20-cm PCB with a ring-style ground plane is equipotential—that is, that every point in the plane is at the same potential (**Reference 7**). Glen Dash, the author of numerous papers on the laws and standards applicable to electronic equipment, soldered two antennas onto the sides of a copper-clad PCB and produced a significant amount of EMI by misrouting the digital chips on the board, causing large, fast-changing currents (**Figure 5**). Experienced engineers looking at the telescopic antennas soldered to a common plane would think that the system would not radiate RF, but they would be wrong.

RF-SUSCEPTIBILITY RULES

To understand the theory behind RF susceptibility, you need to know three general design rules: Low impedance is preferable to high impedance, small loop areas are preferable to large ones, and short wires are preferable to long ones. Some engineers believe that, when everything else fails to solve the problem, they must put the system into a shielded enclosure, but this option is costly and often impractical. “If designers want to avoid that expense, they have to do a good PCB layout,” says Mi-

crochip’s Bible. Consider that a wire in space is an antenna. If the wire’s connection to ground is a 1-M Ω resistor, then the wire’s voltage will vary more widely than if its connection to ground is a 5 Ω resistor. Gaussian law dictates routing two signal-carrying wires close together rather than in a big loop because using bigger loops means that the wire will pick up more voltage for a given RF-field strength. An antenna also works better when it is the same length as the wavelength of the RF field. A 1-cm wire with one side that attaches to earth ground has a 0V signal all along its length for frequencies of less than 1 GHz. At 900 MHz, a 3-in.-long wire becomes a quarter-wave antenna. Even an eight-wave antenna can bring significant RF energy into your systems. These facts highlight the importance of using short traces and tight layouts. The following rules detail ways that you can minimize both susceptibility and RF emissions:

- Attach all cables to ground, the power plane, or both at the same point.
- Connect the sensor ground near where the sensor wire connects to the input chip.
- Run sensor wires next to each other as pairs, even if one side of the sensor is ground or power. This approach ensures that common-mode interference does not become single-ended noise that an amplifier cannot reject.
- Route the sensor wires between the ground and power planes, and arrange the decoupling capacitors in a uniform pattern across the planes.
- Keep the circuit’s impedances as low as possible within the limits of the components’ power dissipation and the product’s power consumption.
- Lay out the circuit using as little space as possible and the smallest components possible within the limits of manufacturability and power dissipation.
- Keep a uniform ground plane, and use discipline in placement and routing to ensure that digital noise stays outside the analog circuits.
- Reference power-supply circuits with large ac circulating currents to a topside copper pour, and then tie them to the ground plane at the output capacitor’s common terminal.

MORE AT EDN.COM 

 Go to www.edn.com/080110df and click on Feedback Loop to post a comment on this article.

FOR MORE INFORMATION

Aerielle www.aerielle.com	Intel www.intel.com
Amp Inc (now, Tyco Electronics) www.tycoelectronics.com/components	James Long www.analog-rf.com
Analog Devices www.analog.com	Kemet Electronics Corp www.kemet.com
Banner Engineering www.bannerengineering.com	Maxim Integrated Products www.maxim-ic.com
Cisco Systems www.cisco.com	Microchip Technology www.microchip.com
Ford Motor Co www.ford.com	National Semiconductor www.national.com
Glen Dash http://glendash.com	Palm www.palm.com
Honda www.honda.com	

- Create a filtered power supply for each IC that requires it. Any power plane measuring larger than 1 in. is susceptible to RFI.

- Send low-impedance signals over any long cable runs.

- Run signals in a stripline between two planes.

- Use differential signals that don't depend on ground or power if possible.

- Use 100-pF capacitors to filter out RF. The self-inductance of a 0.1- μ F capacitor makes it useless at RFs. Use the manufacturer-supplied impedance chart to ensure that the capacitor you select has low impedance at the frequencies you want to suppress (**Reference 8**). The layout can have footprints for low-value capacitors between op-amp input pins, on signal-path power pins, and on other sensitive nodes.

The art of analog design is knowing how to make trade-offs to achieve the desired result. Many designers do a basic debugging of their PCBs with the signal layers on the outside. After meeting the fundamental requirements, they then make the prototype board with the power and ground planes on the outside. This approach puts all the long traces that might radiate or be susceptible to EMI into a gaussian cage that the outer layers form. You can stitch vias along the edges and to separate areas. The vias can connect two outer ground planes on a six-layer board and can feed to decoupling capacitors on a four-layer board on which power is one of the outside planes. A tight, low-impedance layout with careful thought about how the signals tie into the digital system takes

considerable work, but this work is essential to ensure that a system has good RFI and EMI immunity.

If you can do nothing to eliminate the source of the RFI, you must ensure that as little of it as possible couples into your circuits. After that step, judicious choice and diligent characterization of the ICs you pick for the design can improve RFI immunity.**EDN**

REFERENCES

- 1 Rako, Paul, "Measuring nanoamperes," *EDN*, April 26, 2007, pg 42, www.edn.com/article/CA6434367.
- 2 Rako, Paul, "Circulating currents: The warnings are out," *EDN*, Sept 28, 2007, pg 50, www.edn.com/article/CA6372822.
- 3 White, Don, *The EMC Desk Reference Encyclopedia*, ISBN 0-932263-49-6, Don White Consultants Inc, June 1996.
- 4 Hare, Ed, and Michelle Bloom, Editors, *The ARRL RFI Handbook; Practical Cures for Radio Frequency Interference: First Edition*, ISBN-13: 978-0872596832, American Radio Relay League, February 1999.
- 5 Gerke, Daryl, and Bill Kimmel, *EDN Designers Guide to Electromagnetic Compatibility*, ISBN-13: 978-0750676540, Newnes, August 1999.
- 6 De Wagt, Gerrit, and Arie van Starveren, "A Specification for EMI Hardened Operational Amplifiers, Application Note 1698," National Semiconductor, September 2007, www.national.com/an/AN/AN-1698.pdf.
- 7 Dash, Glen, "EMI: Why Digital Devices Radiate," http://glendash.com/Dash_of EMC/Why_Devices_Radiate/Why_Devices_Radiate.pdf.
- 8 "Application Notes for Multilayer Ceramic Capacitors," pg 46, Kemet Electronics Corp, [www.kemet.com/kemet/web/homepage/kechome.nsf/weben/6FB56FCB5EBB9053CA2570A500160913/\\$file/F3101ECerLdPerfChar.pdf](http://www.kemet.com/kemet/web/homepage/kechome.nsf/weben/6FB56FCB5EBB9053CA2570A500160913/$file/F3101ECerLdPerfChar.pdf).

You can reach
Technical Editor
Paul Rako at
1-408-745-1994
and paul.rako@reedbusiness.com.



INSIDIOUS RF

A BROKEN-WAFER STORY

A large semiconductor-machinery company routinely experienced severe EMI (electromagnetic-interference)-susceptibility issues. The machines were so sensitive to EMI that Intel banned maintenance workers' use of radios on the factory floor. This ban occurred after a worker pressed a button on his radio while standing next to a machine, causing the machine to reboot and, ultimately, the loss of an entire lot of expensive microprocessors.

While consulting at this company, I noticed that the mechanical engineers had at several points connected the power-supply return, or ground, to the frame of the machine—a bad practice. They should have tied the braided shield of the power-supply cabling, not the return circuit, to the frame of the machine. Even though these two lines galvanically connect, much like the ground and neutral wires in house wiring, their functions differ. By letting the shield float and tying the power-supply return to the chassis, the engi-

neers had created a set of ground loops. Try as I might, I could not convince the department head, who was a mechanical engineer, that the shield should connect to chassis and that the power-supply return should connect to the frame of the machine at only one point—perhaps with an inductor to isolate the common circuit from noise on the chassis and to keep the noise on the common circuit from entering the chassis. This approach would make the machine's grounding a known system that engineers could evaluate and control and that would thus work properly wherever customers installed the machine.

The department head did not want to correct the grounding of the cables and power-supply return because the process would require engineers not only to change the cable drawings, but also to move or add tapped holes in the machine frame to accommodate the cable-shield-ring terminals. This lack of understanding, coupled with typical big-company bureaucratic inertia, ensured that the company

would have RFI (radio-frequency-interference)-susceptibility problems for many years.

ANOTHER SUCH STORY

While consulting at a different semiconductor-machinery manufacturer, I ran into another RFI problem. This time, we were trying to get TUV (Technische Überwachungs-Verein, or Technical Monitoring Association) to certify the machine for a CE (Conformité Européenne) mark. As with most immunity and EMI-compliance problems, the machine was on the loading dock, waiting for shipment to Europe. The first problem during the immunity testing was the appearance of static and “snow” on the control screen. We managed to convince the examiner that this static was not a failure. We agreed that, although it was undesirable, the operator could still read the screen. After getting a concession on the screen, we continued operating the machine under RF radiation. To our horror, the wafer elevator crashed through a wafer, shattering it into hundreds of pieces. The machine then rebooted and returned to normal.

The TUV inspector would not allow such an egregious susceptibility. The failure dealt with a motorized component that could be a safety hazard. We experimented with this immunity problem and soon found out that the Banner Engineering sensor we used to locate the wafer position was either misreading or not reading the position. We put ferrite beads on the sensor wires. The result was that, although the computer did not reboot, wafers were still breaking. We were about to blame Banner for this problem with its part. Fortunately, we mentioned the situation to the examiner, and he asked how we connected the sensor to our computer. I explained that we had used shielded cable all the way back to the shielded computer enclosure. The TUV examiner asked whether any connectors were in the cable run. I said there was one, where the Banner pigtail ended, and our cable began.

It turns out that the mechanical engineers who designed the cable had used red-brick, four-pin Amp Inc MR (miniature rectangular) connectors. Two pins were for power and ground,

and the third was for the sensor signal. Dutifully, they had connected the shielding through the fourth pin. The problem was that they had stripped back the shielding 2 in. on either side of the cable and bunched it up to crimp it into the pin. The connectors come in a simple plastic shell with no intrinsic shielding. The TUV inspector pointed at the 4 in. of shield the engineers had pulled away from the cable and said: "At RF, this is an open circuit." Furthermore, the 4 in. of unshielded wires next to the shield were long enough to admit high-frequency RF. We switched to nine-pin D-subminiature connectors with metal housings, and the machine passed RFI-compliance tests with no problem.

AN AUTOMOBILE STORY

I worked 30 years ago as an automotive engineer in Detroit. Several things conspired to give the company I worked for RFI headaches. First, the ignition systems were high-energy systems for pollution control. Next, the inner fenders of the cars were now plastic rather than metal. Third,

Canada, one of the countries that would be importing these automobiles, had instituted strict RFI-emissions laws. Finally, there were more and more electronics on the car itself having problems with EMI/RFI. To try to reduce radiation, we "ground" the hoods of the car with small ground straps that connected the hood to the body of the car. Many were baffled when we still experienced high-frequency RF noise.

Ed Winstead, an engineer at Ford Motor Co who had been in the Army Radio Corps, explained that grounding one corner of a big metal car hood would keep out only the radiation that had a longer wavelength than the size of the hood. At hundreds of megahertz and beyond, the hood of the car may as well not have been there; it contributed nothing to the shielding. When it comes to emissions, it's important to kill the noise at its source rather than put multiple patches on to keep the noise out.