

Use the MCLR pin as an output with PIC microcontrollers

Antonio Muñoz, Laboratorios Avanzados de Investigación, Huesca, Spain, and Pilar Molina, Universidad de Zaragoza, Zaragoza, Spain

Although microcontroller manufacturers try to offer designers products that almost exactly fit the needs of their designs, another output pin is often necessary. This situation is particularly true in small designs using microcontrollers with eight pins or fewer. This Design Idea employs the Microchip (www.microchip.com) PIC10F222. The PIC10F222 comes in an SOT23-6 package and offers three I/O pins, one input pin, RAM, flash, and an ADC module. You must program these tiny microcontrollers, just as you do with their big brothers. To program these microcontrollers, you need the MCLR, two I/O pins (data and clock), and supply pins (V_{CC} and GND). To enter programming mode, you need MCLR and supply. Because the microcontroller must differenti-

ate between normal and programming mode, the MCLR pin usually reaches a voltage of approximately 12V to enter programming mode. Thereafter, in normal operation, you can configure the MCLR pin either as an external reset or as an input-only pin.

This design uses one pin for analog input and the other three as outputs. The design thus requires an additional output. For that reason, this circuit uses the MCLR pin as an output. For simplicity, **Figure 1** shows only the GP3/MCLR output circuit. To allow the GP3/MCLR pin to act as an output, the circuit uses the configurable weak pullups that this microcontroller offers. The selected function for the GP3/MCLR pin is input, and you must enable the global weak-pullup bit in the microcontroller's configuration

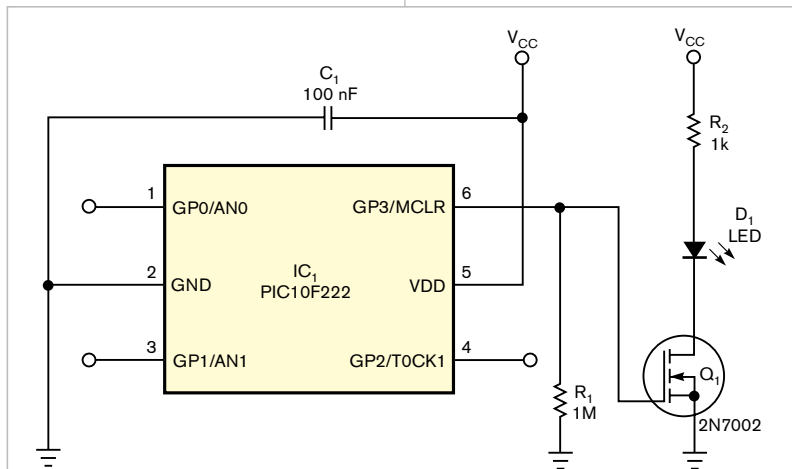

Figure 1 Adding a MOSFET and associated circuitry to a PIC microcontroller's MCLR input pin transforms the pin into an output.

DIs Inside

66 High-speed clamp functions as pulse-forming circuit

68 Depletion-mode MOSFET kick-starts power supply

70 Simple continuity tester fits into shirt pocket

72 White LED shines from piezoelectric-oscillator supply

► **What are your design problems and solutions? Publish them here and receive \$150! Send your Design Ideas to edndesignideas@reedbusiness.com.**

word. Although you cannot individually configure weak pullups, this inability is not a problem because you configure all other pins as analog inputs or digital outputs.

The weak pullups have a resistance of 20 to 150 k Ω , depending on supply voltages, so this circuit uses transistor Q_1 to drive higher loads, such as the depicted LED. R_1 drives the transistor off when you deactivate the pullups. Because the transistor's gate is resistance-driven, the maximum toggle frequency depends on the chosen transistor. The worst-case scenario occurs when you need to switch off Q_1 . R_1 and Q_1 's gate-to-source capacitance determine the transistor's switch-off time.

Programming voltages for the MCLR pin are about 12V. Therefore, Q_1 must withstand a gate-to-source voltage higher than this value. This design uses a MOSFET having a $\pm 18V$ withstand voltage. For this reason, you should not use digital MOSFETs. You can use this circuit with other PIC microcontrollers and with most RS08KA family microcontrollers from Freescale. **EDN**

High-speed clamp functions as pulse-forming circuit

Marián Štofka, Slovak University of Technology, Bratislava, Slovakia

Amplifiers with positive feedback are the bases of signal-grade pulse-forming circuits. This setup ensures a triggerlike operation in which the input signal crosses the input-threshold level; in most cases, the input signal is a voltage signal. The most well-known of these triggers is the Schmitt trigger, which, by the way, will this year celebrate its 70th birthday. British scientist OH Schmitt in 1938 originated the Schmitt trigger in the form of a two-stage amplifier with current feedback. The two active devices were vacuum tubes.

The operation of a Schmitt trigger has the advantage of fast, almost-constant transition times of the output regardless of the slope of the input signal. One consequence of this type of operation is the hysteresis in the I/O characteristic. In other words, the thresh-

old shifts to a higher value before the positive-output transition, and it shifts to a lower value after switching to the positive-output level. You can set the amount of hysteresis—from zero to latch-up—for Schmitt-trigger circuits comprising discrete parts. Schmitt circuits find wide use in logic ICs, in which the hysteresis is rather high and fixed.

As an alternative, you can use a circuit—a fast-response voltage limiter, or clamper—as a pulse-forming circuit. The input-voltage range is narrower than that of Schmitt-trigger circuits, because, at low input voltages, the voltage limitation becomes inactive, and the circuit operates as a linear amplifier. On the other hand, because of its nonhysteretic behavior, the decision threshold of the input voltage is precise and equal for both directions

of output-level transitions. **Figure 1** shows one example of such a circuit. The voltage limiter in **Figure 1** is an inverting amplifier with a highly nonlinear negative feedback. For output voltages ranging from -0.3 to $+0.6$ V, the feedback impedance is high because each of the diodes is nonconducting. The forward-voltage drop of the selected Schottky-barrier diodes determines these voltage limits (**Reference 1**). The voltage gain of the inverting amplifier is thus almost that of the op amp's open-loop gain.

Whenever the output voltage exceeds these limits, diode D_1 , D_2 , or D_3 —depending on the polarity of the output voltage—starts to conduct. The differential gain of the amplifier then drops to the value of $-R_1/2R_D$ and $-R_1/R_D$, respectively, where R_D is the equivalent-series resistance of a single diode. The action clamps the output voltage to approximately 0.8V and to -0.4 V even for large input voltages. The **figure** uses an Analog Devices (www.analog.com) AD8045 VHSIC (very-high-speed integrated-circuit) op amp because its slew rate exceeds the value of 1V/nsec (**Reference 2**).

Figure 1's circuit has an asymmetrical-limiting configuration to compare the single feedback diode with two series-connected diodes having a transverse resistor, R_{T1} , between their midpoints and ground. The clamping circuitry comprising D_1 , D_2 , and R_{T1} offers higher off-isolation between the output and the input of the op amp than that of the single diode, D_3 . When D_3 is on, you can observe small, weakly damped oscillations at approximately 200 MHz in the output waveform. Oscillations manifest themselves less at the beginning of turn-on of the D_1 and D_2 diodes. **EDN**

REFERENCES

- 1 "Surface Mount RF Schottky Barrier Diodes," Avago Technologies, www.avagotech.com/.
- 2 "AD8045 3 nV/ $\sqrt{\text{Hz}}$ Ultralow Distortion Voltage Feedback High Speed Amplifier," Analog Devices, 2004, www.analog.com/en/prod/0,,ad8045,00.html.

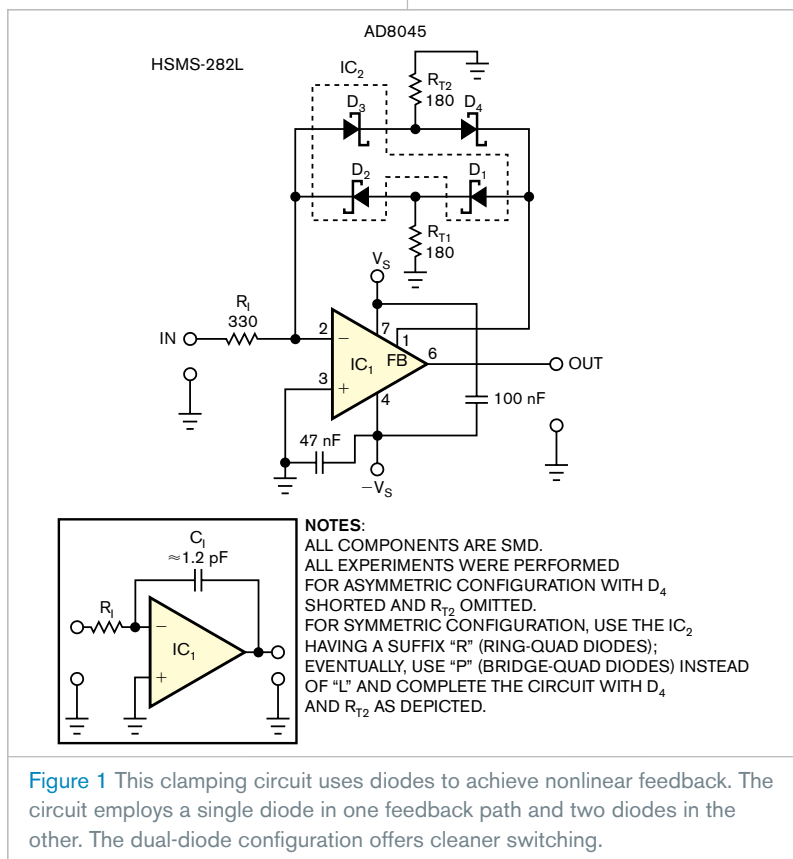

Figure 1 This clamping circuit uses diodes to achieve nonlinear feedback. The circuit employs a single diode in one feedback path and two diodes in the other. The dual-diode configuration offers cleaner switching.

Depletion-mode MOSFET kick-starts power supply

Gregory Mirsky, Milavia International, Buffalo Grove, IL

Many switch-mode power supplies use “kick-start” circuits to initialize their offline operation. These circuits may be simple resistors, such as International Rectifier’s (www.irf.com) IRIS4015, or more complicated arrangements built with bipolar transistors or MOSFETs (**Reference 1**). These transistors provide the initial current for the flyback or PFC (power-factor-correction) IC. When such a power supply starts operating in normal mode, a supply voltage from a dedicated winding keeps supplying the PFC IC, thus reducing power consumption of the kick-start circuitry.

Such schemes reduce—but do not eliminate—the power consumption of the kick-start circuitry, because the active component is usually a high-voltage bipolar transistor or high-voltage enhancement-mode MOSFET. These transistors’ base or gate requires forward-biasing with respect to the emitter or the source for normal operation. Therefore, a power loss always occurs in the circuits that keep the transistors in the off state. Unfortunately,

engineers pay too little attention to depletion-mode MOSFETs, which require no forward-biasing for normal operation and, moreover, require gate potentials below the source. These valuable properties of depletion-mode MOSFETs suit them for a role in no-loss kick-start circuits for power supplies.

Figure 1 shows a conventional PFC circuit whose IC initially receives power from the output through a depletion-mode MOSFET, Q_2 , a DN2470 from Supertex (www.supertex.com, **Reference 2**). Q_2 ’s source feeds PFC IC IC_1 with an initial supply current of approximately 10 to 15 mA or less depending on the IC model. A brief power dissipation of approximately 4 to 6W can do no harm to the MOSFET soldered to a copper pour. If you have concerns about the MOSFET’s health, you can use an IXTY02N50D from Ixys (www.ixys.com, **Reference 3**). Resistors R_3 and R_4 set up Q_2 ’s working point to obtain the minimum required current. Zener diode D_5 limits voltage across IC_1 to approximate-

ly 15V for an input voltage of 18V, which is usually necessary for most PFC ICs and is less than the maximum for MOSFET Q_2 .

When IC_1 starts working normally, the secondary winding of the PFC inductor, L , generates the IC’s supply voltage, which diodes D_1 and D_3 and capacitors C_1 and C_2 condition. Transistor Q_2 keeps feeding zener diode D_5 and IC_1 for a short interval. Eventually, bipolar transistor Q_3 gets its base supply through resistor R_5 from diode D_2 , turning on and clamping Q_2 ’s gate to ground. Q_3 ’s power source is the IC’s positive-supply potential of approximately 15V, which is more than enough to shut off Q_2 . The residual thermal current of 10 to 20 μ A produces no substantial power loss. **EDN**

REFERENCES

- 1 “IRIS4015(K) Integrated Switcher,” Data Sheet No. PD60190-C, International Rectifier, www.irf.com/product-info/datasheets/data/iris4015.pdf.
- 2 “DN2470 N-Channel Depletion-Mode Vertical DMOS FET,” Supertex Inc, www.supertex.com/pdf/datasheets/DN2470.pdf.
- 3 “High Voltage MOSFET: IXTP 02N50D, IXTU 02N50D, IXTY 02N50D,” Ixys, http://ixdev.ixys.com/DataSheet/98861.pdf.

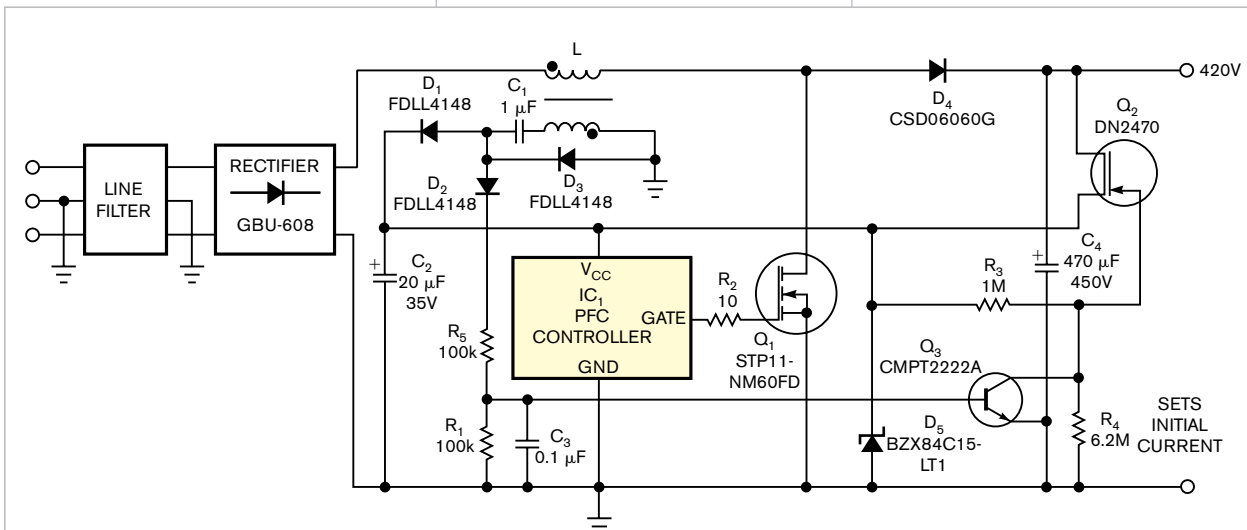

Figure 1 A depletion-mode, high-voltage MOSFET provides a kick-start for a PFC IC. During normal operation, the MOSFET switches off and dissipates negligible power.

Simple continuity tester fits into shirt pocket

Tom Wason, Phoenixville, PA

This Design Idea describes a handy continuity tester with two modes of operation: It may sound if it detects continuity between its two probes, or it may sound when it detects no continuity. The second option permits testing for intermittent cable breaks. Response must be sufficiently fast to permit swiping a probe across perhaps 100 pins to instantly find a connected pin. The tester may also identify microfarad or larger capacitance between two conductors.

To properly test for continuity, the tester's voltage and current are limited so that low-power semiconductors do not suffer overstress or appear as a connection between two conductors. The tester must protect itself if you accidentally connect it across an energized circuit or a charged capacitor. Power consumption must be low so that if you accidentally leave the tester on overnight, it will not discharge the battery. The tester must operate even with low battery voltage.

Continuity requires a threshold of less than 200Ω . Depending on battery voltage, that threshold may even

be 80Ω . The tester's open-circuit voltage is less than $0.5V$. Its short-circuit current is approximately 1 mA . Values are low so that the tester doesn't mistake a Schottky-barrier rectifier for continuity. When the tester is silent, it draws slightly more than 1 mA of current from a $9V$ battery. You can connect the probes for a few seconds across any voltage from -50 to $+200V$ without damage.

A feedback circuit comprising Q_1 PNP and Q_2 NPN transistors maintains voltage on the gate of IGFET Q_3 at less than $1.4V$ despite a $680\text{-k}\Omega$ pullup resistor, R_4 , and current from D_2 (Figure 1). When you short the probes, you divert more Q_1 base current to the probes, and less current flows through D_2 . Eventually, Q_2 can no longer maintain a low Q_3 gate voltage. As the gate voltage exceeds $1.8V$, Q_3 's drain-to-source current causes Q_4 to become nonconductive. A $1\text{-M}\Omega$ pullup resistor, R_6 , then applies $9V$ to Q_5 's gate, causing the tester to sound, announcing continuity.

Without a conducting Q_2 collector,

Q_3 's gate voltage approaches $9V$. Current would then leak through Q_1 's collector-to-base path. Diode D_2 blocks Q_3 's gate voltage from leaking to the shorted probes.

The tester detects instantaneous continuity even when you quickly swipe a probe across 100 pins. Capacitor C_1 and pullup resistor R_5 extend Q_3 's low gate-voltage response by 20 msec . Thus, the tester sounds slightly longer to indicate that it has established connectivity and does not miss a conductive pin during a fast swipe.

Probe current charging a capacitor may also create a short beep. The 20-msec extended beep means that the tester detects even $10\text{-}\mu\text{F}$ or smaller capacitors. With practice, you can estimate capacitance within decades from the beep's period.

Diodes D_3 through D_5 block destructive currents if probes touch an energized circuit. Resistor R_3 must be at least $\frac{1}{2}W$ to withstand current from an energized circuit for a few seconds without damage.

To test for cable continuity, the tester sounds only during a broken connection. In this case, firmly connect the probes to both ends of the cable. Switching S_2 changes the tester's function so that Q_4 drives the buzzer during a cable break.

You can modify the circuit to be a better cable tester by reducing the value of resistor R_1 to $4.7\text{ k}\Omega$ and omitting capacitor C_1 . With these modifications, detecting loss of continuity occurs at a threshold resistance of less than 100Ω .

Unfortunately, a continuity tester may create noise currents that feed back into the sensitive Q_1/Q_2 detector. Three circuit features minimize that noise. First, capacitor C_2 connects across the buzzer. Second, IGFET Q_3 acts as a buffer. Last, diode D_5 grounds Q_4 and Q_5 separately from ground for Q_2 and Q_3 .

The circuit performs even when a battery voltage is less than $6.5V$. However, lower battery voltage means that the tester detects continuity at a higher threshold resistance. You may install the entire tester in a plastic case smaller than a pack of cigarettes. **EDN**

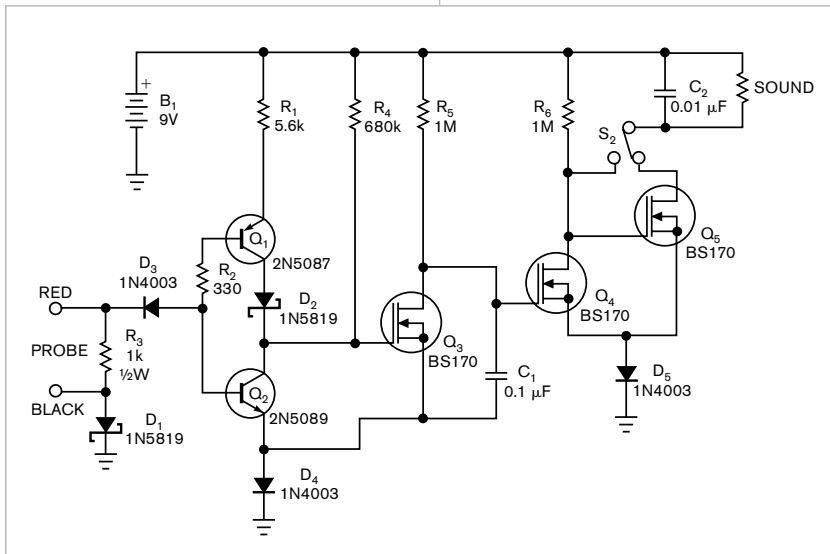

Figure 1 This simple continuity tester is switch-selectable to sound on either shorts or opens. It prevents a user from accidentally connecting it across live circuits.

White LED shines from piezoelectric-oscillator supply

TA Babu, Chennai, India

LED drivers that receive their power from a single cell are receiving a great deal of attention. To generate the high voltage for illuminating a white LED from a low-voltage power supply basically requires some form of an electronic oscillator, and one of the simplest is a piezoelectric buzzer. An unusual application of a piezoelectric transducer serves as an oscillator and drives a white LED (Figure 1). The piezoelectric diaphragm, or bender plate, comprises a piezoelectric ceramic plate, with electrodes on both sides, attached to a metal plate made of brass, stainless steel, or a similar material with conductive ad-

hesive. The circuit uses a three-terminal piezoelectric transducer. In this transducer, the diaphragm has a feedback tab on one of its electrodes. The oscillation is a result of the resonance between the inductor and the element, which is capacitive. The frequency of operation is: $f_{\text{OSC}} = 1/(2\pi\sqrt{LC})$, where L is the value of the inductor and C is the capacitance of the piezoelectric element.

With the initial application of potential to the circuit in Figure 1, transistor Q_1 turns on. When the transistor conducts, the current through inductor L_1 increases gradually, and the potential across the plates flexes the piezoelectric ceramic. This flexing generates a negative potential at the feedback tab, which feeds back to the base of the transistor. The transistor then switches off. When turn-off occurs, the stored energy in the inductor dumps into the LED. This flyback voltage is sufficient to light the LED. **EDN**

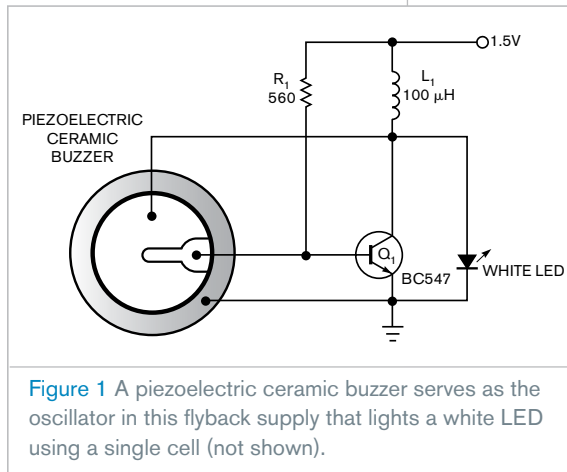

Figure 1 A piezoelectric ceramic buzzer serves as the oscillator in this flyback supply that lights a white LED using a single cell (not shown).

hesive. The circuit uses a three-terminal piezoelectric transducer. In this transducer, the diaphragm has a feedback tab on one of its electrodes. The oscillation is a result of the resonance between the inductor and the element, which is capacitive. The frequency of operation is: $f_{\text{OSC}} = 1/(2\pi\sqrt{LC})$, where L is the value of the inductor and C is the capacitance of the piezoelectric element.

With the initial application of potential to the circuit in Figure 1, transistor Q_1 turns on. When the transistor conducts, the current through inductor L_1 increases gradually, and the potential across the plates flexes the piezoelectric ceramic. This flexing generates a negative potential at the feedback tab, which feeds back to the base of the transistor. The transistor then switches off. When turn-off occurs, the stored energy in the inductor dumps into the LED. This flyback voltage is sufficient to light the LED. **EDN**