

Digital TV for the future: hybrid analog/digital-TV-receiver design

ANALOG TV HASN'T DISAPPEARED YET, SO YOU STILL NEED TO UNDERSTAND IT WHEN DESIGNING HYBRID ANALOG/DIGITAL SYSTEMS.

Analog is rapidly disappearing, but you still need to worry about developing analog-TV receivers because, in most parts of the world, it will be some time before manufacturers eliminate analog TVs. Even then, they may continue to have cable systems that carry analog-TV signals. Smart TV, set-top-box, and PVR/DVR (personal-video-recorder/digital-video-recorder) product developers will plan to include analog in their digital TVs for a long time. To understand hybrid analog/digital-TV-receiver options, you must take a brief look back at the evolution of TV-front-end architectures.

ANALOG-TV ARCHITECTURE

Basic analog TVs receive terrestrial analog-RF (radio-frequency) signals and produce a good picture—not challenging tasks because AM (amplitude-modulation) analog-RF-TV signals require only a moderate-performance noise figure, linearity, phase noise, gain, AGC (automatic-gain-control) response, and frequency stability. Analog-TV-receiver architectures follow a classic heterodyne approach that filters and amplifies

the incoming signal and applies it to a mixer (Figure 1). The mixer translates the RF signal into an IF (intermediate-frequency) signal, further filters and amplifies it, and presents it to the analog-demodulator blocks.

Making analog-TV products “cable ready” required some changes from these basic performance requirements. Terrestrial-broadcast-TV signals differ greatly from cable signals. The FCC (Federal Communications Commission) allocates a transmitter-frequency band to each TV broadcaster. It bases this allocation on a regional frequency plan that aims to eliminate the presence of strong signals on adjacent channels. This system enables TV receivers to detect the channels of most interest to them—those nearest to the user’s home.

The FCC assigns channels to broadcast transmitters in a way that separates the frequency of strong signals, because receivers cannot easily reject interference in close frequency to the desired signal. Otherwise, a high-power signal could reside in the channel adjacent to a desired weak signal and make reception of the weak signal impossible for any practical receiver implementation.

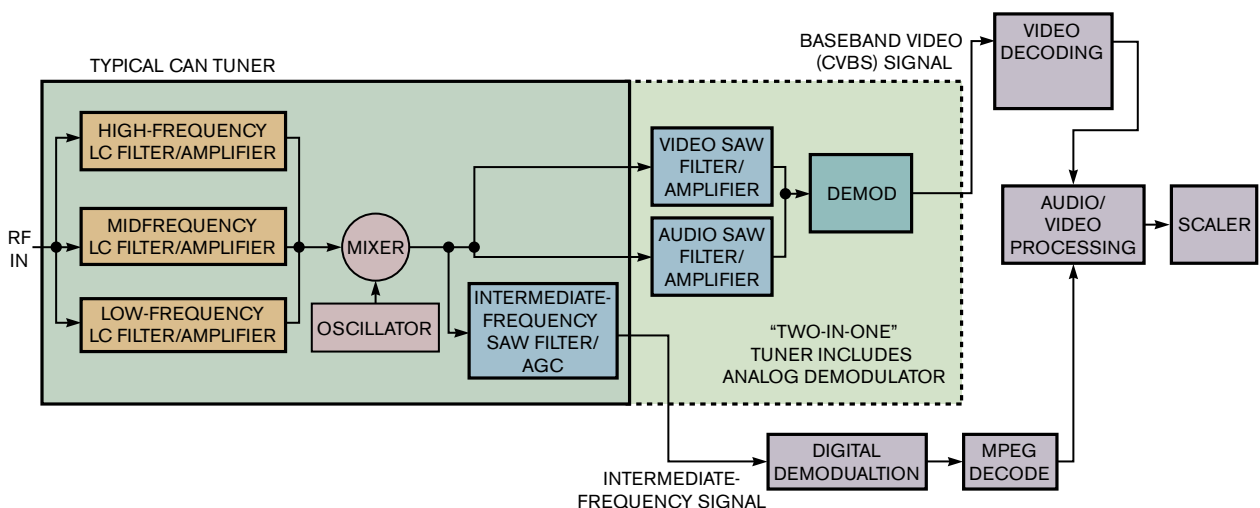

Figure 1 Analog-TV-receiver architectures follow a classic heterodyne approach that filters and amplifies the incoming signal and applies it to a mixer.

In addition to being sparsely spaced in frequency—like a comb with many missing teeth—terrestrial signals that the TV receives have vastly differing power levels because of the varying power levels of transmitters and their proximity to the receiving set. A receiver might be near one transmitter, but it needs to also receive signals from a distant transmitter. TV receivers perform well with off-air signals, which can vary in signal power by nearly three orders of magnitude from milliwatts to microwatts—like a gap-toothed comb with teeth of various lengths.

Conversely, TV signals in a cable system are closely spaced and of relatively equal power—like a new comb—because cable operators must use all of the available spectra to offer as many channel options as possible and the cable medium shields the signals from outside interference. And, because one transmitter generates the signals, cable systems can control the signal levels. Thus, a signal on an adjacent channel cannot be much stronger than a signal on the other channel.

To make an analog TV cable ready simply means that it must deal with closely spaced, equal-level signals and must use all the channels. An RF receiver handling this type of signal must have better linearity than a receiver for terrestrial analog receivers. RF linearity generally has 1-dB compression and third-order intercept, but, because of the many channels in cable systems, the TV industry has developed TV-specific parameters: CSO (composite-second-order) and CTB (composite-triple-beat) parameters for specifying a receiver's resistance to intermodulation effects. Tuner products for use in cable-ready TVs will include these specifications.

THE RISE OF DIGITAL TV

A simple digital-TV architecture would include a receiver section for digital-terrestrial signals. Digital-TV standards bod-

ies have developed specifications, such as the ATSC (Advanced Television Systems Committee) A/74, that receivers must meet to provide good reception of the new digital-TV signals. Generally, the digital-terrestrial-TV receivers have a better noise figure, overall gain, selectivity, linearity, and AGC range and response than their analog counterparts. Digital-tuner modules offer these specifications. However, most early hybrid analog/digital-TV designs used two tuner modules—one for receiving analog signals and the other for receiving digital signals. This approach increased the cost, size, and power consumption of the designs. On the other hand, it also allowed designers to include additional filtering, amplification, or both to either the digital or the analog tuner to further increase performance. Most digital TVs also included two threaded, F-type RF connectors with “analog,” “digital,” “air,” and “cable” labels.

To keep up with flat-panel TV screens, TV developers must work with constantly shrinking PCBs (printed-circuit boards). A hybrid tuner and RF switch provide dual inputs with a single tuner module. More recently, designers have developed hybrid analog/digital-capable tuner modules. These new designs provide the performance for DTV and meet the demanding requirements of TV manufacturers for analog-terrestrial and cable reception. New TV designs employ these modules, sometimes with an RF switch so that dual input connectors could still be available at the back of the TV. In some cases, the TV manufacturer adds application-specific gain or filtering between the tuner module and the connector to enhance the receiver performance. These types of designs frequently include low-noise amplifiers that provide additional gain to achieve better sensitivity when the system is operating in digital mode.

Digital-cable systems generally employ set-top boxes from

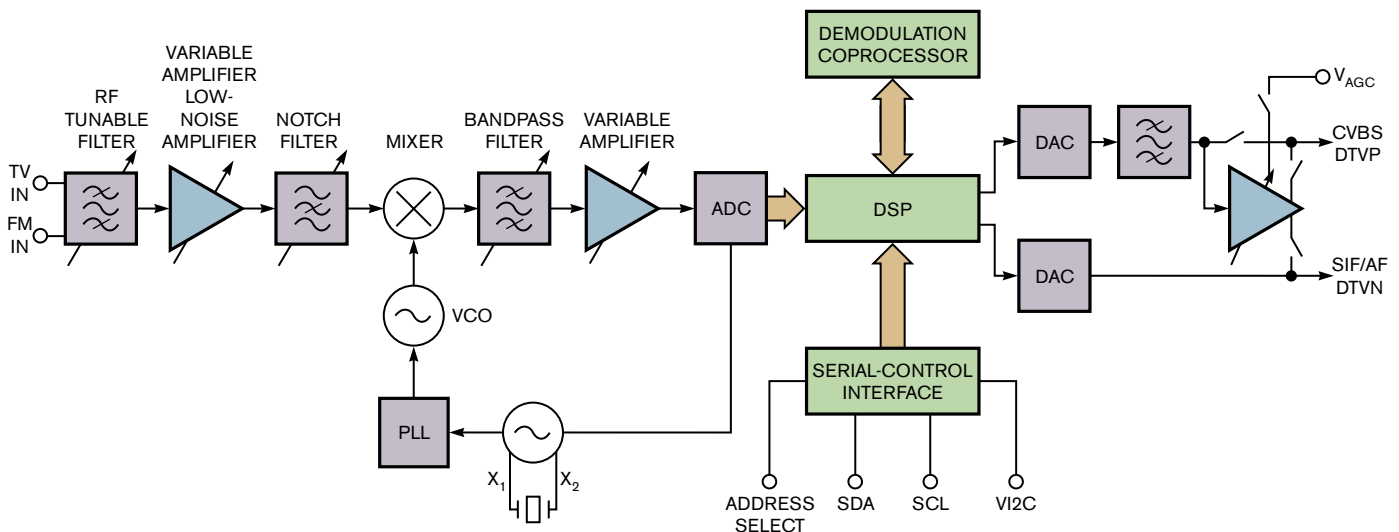

Figure 2 Monolithic silicon tuners offer performance meeting the rigorous requirements of leading TV manufacturers and also integrate all the hybrid-TV-receiver functions, including the analog demodulation, in a 7×7-mm surface-mount package with substantially lower power consumption than currently available CAN modules.

the cable company. However, TV manufacturers have developed “digital-cable-ready” and “clear-QAM” (quadrature-amplitude-modulation)-capable TVs that allow users to directly connect TVs to digital-cable systems without a set-top box. This feature requires the use of RF-receiver electronics to add reception of complex high-order QAM signals. Other requirements include the need to meet analog-off-air, analog-cable, and digital-off-air specifications. Digital-cable signals are the most complex signals to receive. Thus, designers must address new, critical specifications, such as digital sensitivity, adjacent-channel rejection, and phase noise, to meet digital-cable requirements. The newest tuner-module products in the latest DTV designs meet all of these requirements.

Analog-TV designers usually include the demodulator as part of the tuner module. Many tuner-module products are available that provide analog demodulation, although TV manufacturers sometimes select RF-only tuners and implement the analog-demodulation function with discrete components that they mount on the TV’s main board between the tuner and the video/audio-processing blocks. Hybrid-tuner modules also include the analog-demodulation function. In analog mode, the outputs are CVBS (composite-vertical-blanking-signal) baseband video and SIF (sound intermediate frequency). Digital mode uses different filter- and AGC-amplifier sections, and a narrowband digital-mode IF acts as the output to a digital demodulator. Some people refer to this type of hybrid-tuner module as a two-in-one tuner, indicating that it includes both a tuner and an analog demodulator.

MORE AT EDN.COM ▶

+ Go to www.edn.com/ms4277 and click on Feedback Loop to post a comment on this article.

The ideal approach, however, would be a single block that would perform well in both analog/digital and terrestrial/cable modes. Manufacturers have long offered bulky tuner CAN (controller-area-network) modules that address this goal. These modules, which find use in many current TV designs, comprise many discrete parts, including multiple ICs, small surface-mount passives, variable capacitors, and multiple air-coil inductors. Due to the size, power consumption, and complexity of these modules, designers are seeking out alternatives.

ENTER SILICON-TUNER ICs

One approach is to place RF-only tuner modules and select discrete SAW (surface-acoustic-wave) filters and analog-demodulator ICs next to the tuner module on a TV’s main board. This approach allows the designer to select the best components but also increases the main board’s chip count and could require fine-tuning and board redesigns. The ideal approach would employ one chip that offers all the performance and integration of the hybrid two-in-one tuner modules. Although monolithic silicon-tuner ICs have for several years been available, they have only recently been able to match the performance and integration of modules. Monolithic silicon tuners have not found wide use in TV applications due to the difficulties in simultaneously meeting all the demands of analog and digital, terrestrial and cable, and tuning and demodulation at the levels that TV manufacturers require.

However, new silicon-tuner ICs from TV-tuner manufacturers are meeting both the integration and the performance levels of CAN-tuner modules. New models appearing on the market in the coming months will demonstrate that monolithic silicon-tuner ICs can meet the rigorous requirements for new hybrid analog/digital-TV designs. These new monolithic silicon tuners offer performance meeting the rigorous requirements of leading TV manufacturers and also integrate all the hybrid-TV-receiver functions, including the analog demodulation, in a 7×7-mm surface-mount package with substantially lower power consumption than currently available CAN modules (Figure 2).**EDN**

AUTHOR’S BIOGRAPHY



Brian D Mathews is marketing director at Xceive Corp, where he has worked since 2007. He is responsible for product marketing for Xceive’s TV devices. He has a bachelor’s degree in electrical engineering from California Polytechnic University, and his leisure pursuits include off-road motorcycle riding. You can reach him at bmathews@xceive.com.