

BUCK-BOOST CONVERTERS CHANGE WITH THE TIMES



BY PAUL RAKO • TECHNICAL EDITOR

BUCK-BOOST CONVERTERS PROVIDE VOLTAGES BOTH ABOVE AND BELOW THE INPUT VOLTAGE. THIS FEATURE IS USEFUL IF YOUR DESIGN'S INPUT VOLTAGE CHANGES DRASTICALLY OR IF ITS LOAD VOLTAGE VARIES.

Buck-boost converter topologies fit into a wide range of applications. Whether you are charging a battery from a battery, powering a string of LEDs, or running a handheld device from a single cell, the buck-boost topology can provide an important weapon in your arsenal of design tricks. Whether you need low cost, high efficiency, or low noise, some version of buck-boost topology can solve the problem. And, if your buck-boost design works for multiple products, you can save yourself the considerable effort of designing separate power supplies for each load voltage. However, as with any type of design, the buck-boost-converter brings its share of design challenges.

For example, consider one common application for buck-boost converters: battery-to-battery charging, such as using a car battery to charge a 10.8V NiMH (nickel-metal-hydride) battery (**Figure 1a**). At first blush, you might think that you could use a low-dropout linear regulator for this task because the regulator's 10.8V voltage is close to the

12V lead-acid battery's voltage. If the car is running, however, the battery's charging voltage is 13.75 to 14.2V, indicating that you might need to use a switching regulator to prevent power loss. You might still think that a simple buck regulator should do the job. However, NiMH batteries receive their charge from a constant current, so their

cell voltages rise to 1.4 to 1.6V per cell. Thus, for a nine-cell, 10.8V pack, the charge-termination voltage must reach 12.6V. A modern synchronous-buck regulator that can deliver power with 100-mV drop might still do the job, but this approach assumes that the car is running. In a real-world application for test equipment that diagnoses cars, however, you must assume that some cars won't start. A lead-acid automobile battery charges at 13 to 14V, but the no-load voltage is 12V. Clearly, you cannot charge a nine-cell NiMH battery to its 12.6V termination with a 12V source and a buck regulator.

The automotive-test-equipment application may be esoteric, but system designers face a far more common problem: how to power a 3.3V handheld electronic system from one lithium-ion cell (**Figure 1b**). Consider a handheld computer that uses Windows. Its digital electronics, including memory, must operate from a 3.3V power supply, and

one lithium-ion cell delivers 3 to 3.7V of power, so it may be tempting to just operate 3.3V ICs at 3V. However, digital processes are less forgiving than analog when it comes to power-supply-voltage range—to the point that some manufacturers refuse to characterize chips at 3V.

Another approach employs two lithium-ion cells; this method has several disadvantages, however. First, consider that a battery is a more problematic power source than a cell. You must worry about reliability: If either cell fails in an open circuit, the system loses power. If either cell short circuits, the internal fusible link blows—and let's hope it blows before a fire breaks out. In any case, after a short circuit, your product cannot function. Just as troublesome is the problem of balancing the cells' charge. Because batteries are metal-plating devices, you charge them by plating lead, lithium, or nickel from the cathode to the anode. When you discharge the battery, the metal or metal ions discharge from the anode to the cathode. Another problem occurs when you recharge the battery: If one cell in a string accepts less charge, it limits the pack's output. With two lithium-ion cells, this approach would limit the charge voltage to 8.4V. But this approach does not en-

AT A GLANCE

➤ Buck-boost converters find use in automotive, consumer-electronics, and other applications.

➤ Simple buck-boost and Ćuk converters invert the input voltage.

➤ SEPICs (single-ended-primary-inductance converters) and four-switch synchronous H-bridge buck-boost converters do not invert the input voltage.

➤ Many companies are producing synchronous four-switch buck-boost converters for the handheld-system market.

➤ Most buck-boost architectures have 80 to 85% efficiency, whereas the synchronous-four-switch topology has better-than-92% efficiency.

sure that exactly 4.2V exists across each cell. To ensure that amount of voltage, you must implement complex and expensive charge-balancing circuits that charge and discharge each cell at the optimum voltage. For these reasons, most modern handheld products use a single cell. Because lithium-ion cells output 3 to 3.7V, handheld devices requiring 3.3V are appropriate applications for buck-boost converters.

Other broad applications for buck-boost converters are automotive-LED drivers (Figure 1c). They share the same battery-voltage-range issues as the automotive-test equipment. Indeed, even more important restrictions exist for automotive use. When the car is starting, the battery may sag to 8V as it cranks the starting motor. A charger circuit for automotive-test equipment would have to function for a longer time than it takes a car to start. If the power converter is operating a string of brake lights, however, you would not want the output of the circuit to drop out due to input-voltage swings. Buck-boost architectures can handle those cold-cranking periods, as well as a 40V transient from a clamped-load-dump event.

A similar application is driving LED-flash units in a cell phone (Figure 1d). The forward voltage of the LED may be higher or lower than that of a single-cell lithium-ion cell. A buck-boost topology ensures that the flash LED receives the same current no matter what the state of the battery and no matter what process variations of the LED change its forward voltage. "Look at a cell-phone camera where an LED is used in a flash application, perhaps one where you can drive a 0.5A through the LED," says Sam

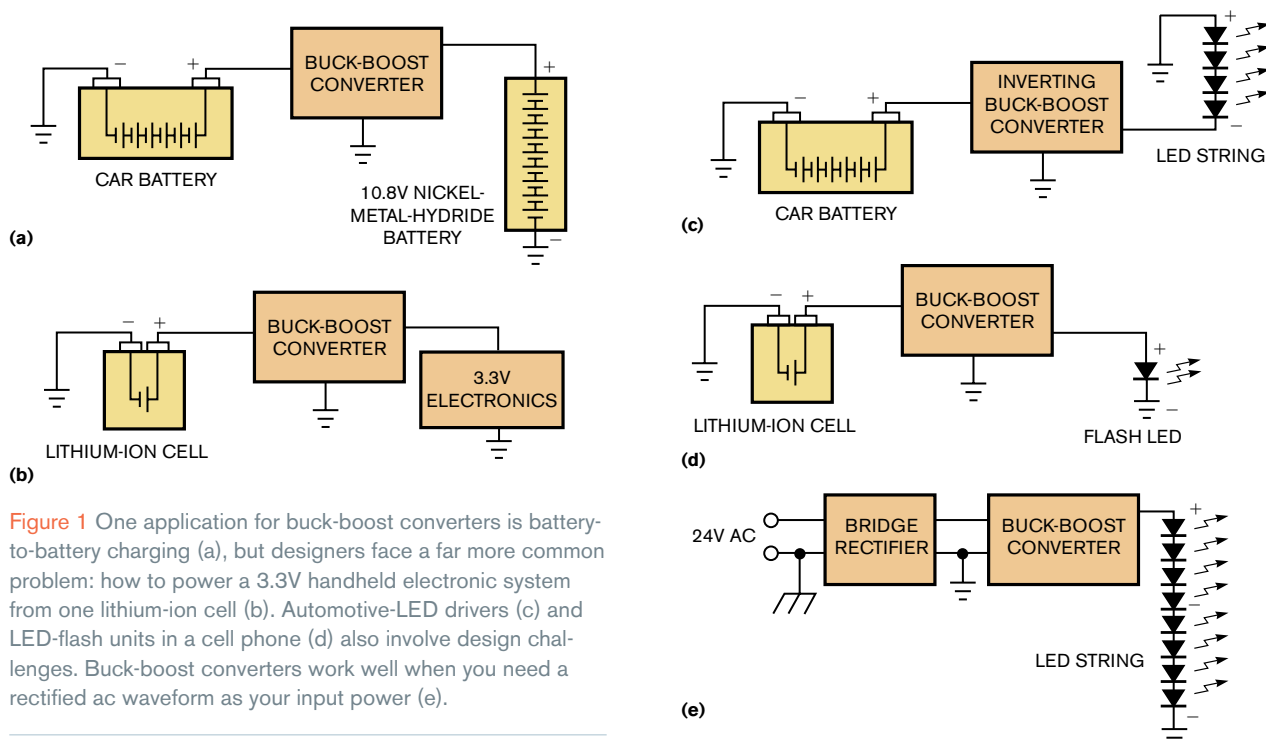

Figure 1 One application for buck-boost converters is battery-to-battery charging (a), but designers face a far more common problem: how to power a 3.3V handheld electronic system from one lithium-ion cell (b). Automotive-LED drivers (c) and LED-flash units in a cell phone (d) also involve design challenges. Buck-boost converters work well when you need a rectified ac waveform as your input power (e).

Nork, a design manager at Linear Technology. “Under those conditions, the forward-voltage drop of the LED is around 3.6V. Depending on temperatures, part variations, and battery conditions, that [situation] is a classic case where you would like a buck-boost converter to get the best performance.” The same design benefits apply to LED flashlights that use lithium-ion cells for power.

Although you might think of buck-boost converters when dealing with a widely variable input voltage, they also work well in applications in which the output voltage varies due to component variations. Rohit Tirumala, staff application engineer at Supertex, points out that some general-lighting applications use an inexpensive 24V “brick” supply. Although the input voltage is fairly regulated, the output voltage across an LED string can vary widely from part to part. “Because of the LED-voltage variation, the string of LEDs might require a buck or a boost,” he says. “For example, each LED can vary by as much as 1V. The forward voltage can be 3 to 4V, so a six-LED string might require 18 to 24V.”

Brian Wengreen, product-marketing manager at Analog Devices, points out that Panasonic and other lithium-ion-battery manufacturers are creating modified battery chemistries that produce more energy as the battery discharges from 3 to 2.5V. “A cell phone or camera that operates from a single [lithium-ion] cell may have a zoom lens or some sort of actuator that requires a steady voltage that provides torque to a mechanical system,” he says. These camera manufacturers use buck-boost converters in this case because they can wring that last bit of energy from the battery.

These examples show how buck-boost converters provide power as both the input- and the output-voltage requirements vary. These converters

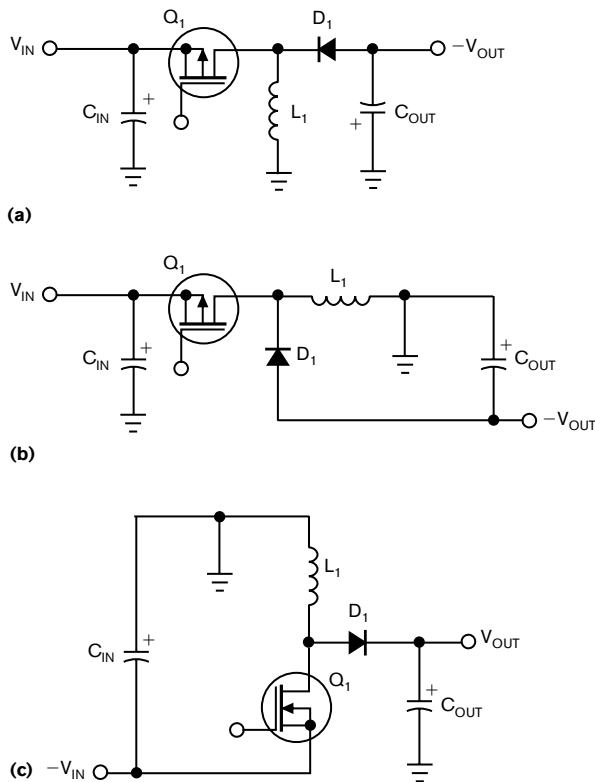

Figure 2 The conventional buck-boost architecture inverts the input voltage (a). You can see that the same circuit with a 5V input would work just as well, producing -4 and -6 V (b). Buck-boost circuits can also invert a negative voltage to a positive one (c).

are also versatile. “Some engineers want to have different models of product that use the same power supply,” says Tirumala. “One model might use four LEDs; one model might use six LEDs. They can use the same buck-boost power supply, [so] the cost will go down, and the volumes will increase.” He also points out that a buck-boost converter works well when you are using a rectified ac

waveform as your input power (**Figure 1e**). One such application is an LED replacement for the ubiquitous 12V halogen bulb, such as an MR16. The halogen-lamp fixture drives the bulb with an ac or rectified-ac waveform. By using a buck-boost circuit in the base of the replacement-LED bulb, designers can ensure a more constant average current as the input voltage varies.

DELVE INTO DETAILS

Knowing that so many applications exist for buck-boost circuits, it behooves diligent analog-system engineers to learn more about them. Start with the terminology. An isolated-flyback converter can provide a fixed output voltage even as the input voltage swings higher and lower than the output. Yet no one refers to a flyback converter as a buck-boost converter. Another example is the PFC (power-factor-correction) circuit in an offline power supply. Even though the first stage is a boost converter and the second stage is a buck, engineers rarely refer to this architecture as a buck-boost converter. Switched-capacitor buck-boost circuits, such as National Semiconductor’s LM3355, exist, but most designers think of inductive converters when they hear the term “buck-boost.” Other sophisticated converter topologies, such as the isolated Tesla Converter from Tesla, can perform the buck-boost function, but engineers also do not refer to them as “buck-boost” converters.

The classic buck-boost is a single-switch converter with an inverting architecture (**Figure 2a**). Because it is inverting, the circuit can have an output voltage either higher or lower than the input voltage, no matter which voltage is changing or whether both are changing. When the switch closes, the inductor builds up a current. When the

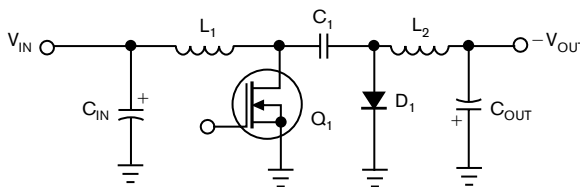

Figure 3 The Ćuk buck-boost topology also inverts. It uses two inductors, which lower the fast-slewing currents into both the input and output capacitors.

switch opens, the inductor still tries to flow that current, so the switch side of the inductor goes negative, and the inductor current then charges up the output capacitor to a voltage that is negative with respect to the input voltage. With a 5V input, the circuit would work just as well, producing -4 and -6 V (**Figure 2b**). As with most other power architectures, there are many valid variations on the single-switch converter. By rearranging the inductor, you can make a negative-to-positive buck-boost converter (**Figure 2c**). Like simple buck or boost architectures, the buck-boost converter can operate in either continuous or discontinuous mode.

The simple inverting buck-boost topology certainly works, but one drawback is that the switching action of the power transistor creates a high current ripple in the input capacitors. California Institute of Technology Professor Slobodan Ćuk solved this problem in 1976

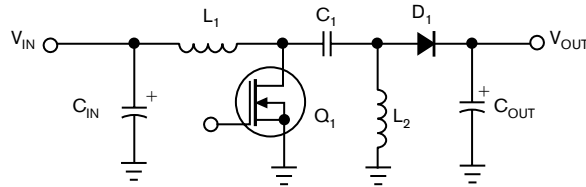

Figure 4 The SEPIC (single-ended primary inductance converter) can buck or boost one positive voltage to another positive voltage. The capacitor in the power path prevents backflow from the output to the input.

when he invented the Ćuk-converter topology (**references 1 and 2 and Figure 3**). By adding a second inductor and using a capacitor to transfer the energy, the Ćuk converter surrounds the switch with inductors. Because the input capacitor feeds the nonswitching side of an inductor, no input current changes faster than a triangle wave. Similarly, the circuit feeds the output capacitor with the nonswitching side of a second inductor, so a triangle wave of current also charges those capacitors, yielding less ripple voltage and, therefore, less heat in the capacitors. Although using

two inductors is more expensive, you can often use lower-value input and output capacitors, which can provide cost savings. The slower-changing capacitor currents cause the circuit to generate less EMI (electromagnetic interference) and RFI (radio-frequency interference)—a boon for automotive applications. The slow-input-current variation means

that you can eliminate the use of an input capacitor, and, because the current over the car's wiring is a triangle wave, the converter circuit does not generate much objectionable electrical noise.

One limitation of both conventional buck-boost and Ćuk converters is that, unlike a SEPIC (single-ended-primary-inductance-converter), they invert the input voltage. Like the Ćuk converter, the SEPIC uses two inductors (**Figure 4**). The SEPIC transposes the position of the inductor and the diode so that the output voltage is positive. The downside is the inductor and the diode are

in the opposite place from those in the Ćuk converter and thus impress a higher instantaneous rate of current change across the output capacitor. The SEPIC also provides a noninverted output voltage, so you can adapt almost any boost-converter IC to a SEPIC topology. Some companies, including Linear Technology, label parts, such as the LT1513, as SEPIC ICs.

One benefit of both the Ćuk and the SEPIC architectures is that they do not allow power to flow back through the converter because they include a capacitor that transfers the energy from the input to the output. This feature may provide a significant benefit in battery charging. The capacitor prevents current from flowing from the battery backward through the part and into the input.

Another application that needs the input and output

voltages to be the same polarity is a circuit that converts a 4.2 to 2.5V lithium-ion cell voltage to 3.3V. You could use SEPICs in this application, but they commonly have efficiency of only 82 to 85%. When trying to squeeze every last bit of energy from a lithium-ion cell, this efficiency is unacceptable. In this case, designers can turn to a four-switch synchronous-buck-boost architecture (Figure 5). This topology uses only

one inductor but four power transistors to make the inductors serve as buck or boost converters, depending on the input voltage. The input and output current may experience greater ripples than those for a Ćuk converter, but handheld devices now use ceramic power capacitors that have low ESR (equivalent-series resistance) and ESL (equivalent-series inductance) so the ripple currents create no associated ripple voltage. As

you might imagine, the challenge with the synchronous-buck-boost converter is control. Two power switches act to convert between buck and boost modes. The other two transistor switches are synchronous rectifiers just as they are in synchronous-buck or synchronous-boost converters. All four transistors must switch seamlessly as the converter slews between the buck and the boost modes.

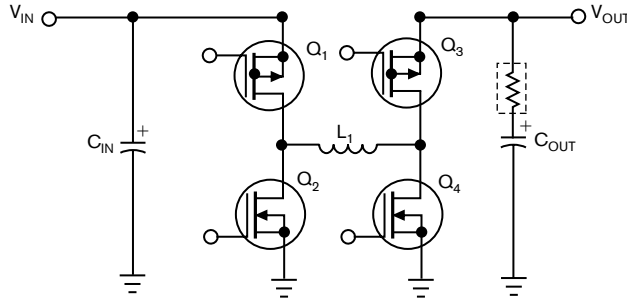

Figure 5 The synchronous-H-bridge four-switch buck-boost converter also creates a positive voltage but with higher efficiency than the other architectures.

FOR MORE INFORMATION

Analog Devices

www.analog.com

Linear Technology

www.linear.com

Panasonic

www.panasonic.com

National

Semiconductor

www.national.com

Supertex

www.supertex.com

Tesla

www.teslaco.com

Texas Instruments

www.ti.com

The handheld-system market, with its high volumes and good margins, has caused many vendors to rise to the challenge of making synchronous buck-boost converters. "We have taken that traditional four-switch buck-boost and broken it up into two control loops to give you either a boost converter or a buck converter," says Michael Day, an applications manager at Texas Instruments. "We have optimized the control system to provide maximum efficiency at a 3.6V input voltage." According to Day, some conventional four-switch buck-boost topologies operate all four switches at once when the input and output voltages are close to each other.

Carl Nelson, an analog designer at Linear Technology, calls this mode "fly-back" because the part stores energy in the inductor and then switches it into the output capacitor. The TI TPS63000 uses its two control loops to operate either the buck or the boost switches but never all four. This approach allows the units to achieve better than 95% efficiency over a wide input range. As the part switches between buck and boost operation, it may seem as though all four switches are operating at once, but the part is first performing one buck cycle and then a boost cycle. As soon as the input and output voltages diverge, the part locks into one mode of operation. Because the part never operates in four-switch mode, the synchronous FETs are simply serving as low-loss diodes.

Similarly, Linear Technology offers the LTC3440, which debuted in 2001 and now includes more than a dozen parts. The company also offers the LTM4605 module, whose efficiency never falls below 93%, along with a buck-boost controller that allows you to use four external transistors. The LTC3780 can take as much as 36V on the input, so you can use it in automotive and industrial applications requiring the buck-boost function.

Because the number of applications using lithium-ion batteries is grow-

ing, many analog-design companies are making parts to buck and boost the battery voltage. For example, Analog Devices recently released the four-switch H-bridge-synchronous ADP2503 and ADP2504 buck-boost converters with a switching frequency of 2.5 MHz. The devices use an average-current-mode architecture to improve transient response, providing good load regulation and preventing overshoot when delivering a sudden current surge. Like other synchronous-buck-boost parts, the ADP2503 can provide power from one lithium-ion cell and maintain more than 92% efficiency. The part also has a low quiescent current, so efficiency remains high even at low output-power levels. Another device, National Semiconductor's LM3668, bucks or boosts a lithium-ion cell to 3.3V or similar voltage, outputs 1A, and switches at 2.2 MHz.

IC vendors have reduced the complexity and the design challenge of compensating a system that may have as many as four poles in the power path. This feature allows system designers to concentrate on the architecture of the products rather than the minutiae of the control algorithms for a power converter. Ćuk, SEPIC, and buck-boost topologies are all becoming as easy as the ubiquitous buck regulator to use. Be sure to consider these topologies in your next design. **EDN**

REFERENCES

- 1 "Ćuk converter," http://en.wikipedia.org/wiki/Buck-boost_converter.
- 2 Middlebrook, RD, and Slobodan Ćuk, "A general unified approach to modeling switching converter power stages," *International Journal of Electronics*, Volume 42, Issue 6, June 1977, pg 521.

MORE AT EDN.COM

Go to www.edn.com/080501df and click on Feedback Loop to post a comment on this article.

You can reach Technical Editor Paul Rako at 1-408-745-1994 and paul.rako@reedbusiness.com.

