

Unraveling the dynamic-range specification in modern spectrum analyzers

USING A RELATIVELY SIMPLE CHART TO CALCULATE DYNAMIC RANGE, ALONG WITH SPEED AND ACCURACY SPECIFICATIONS, ENSURES THAT YOU CHOOSE THE RIGHT SPECTRUM ANALYZER AND MAKE APPROPRIATE PRICE/PERFORMANCE TRADE-OFFS.

Wireless-communication technologies are evolving from 2G, 2.5G, and 3G to 3.9G technologies. Consumer demand for seamless access to data and personal content—that is, voice, music, and video—is driving this technology evolution. The goal of modern wireless communication is to provide users with faster and more sustainable data rates in more locations. The technologies are also using expensive spectra to provide carriers with cost advantages. To provide the high data rates that some applications require, modern technologies have had to increase the channel bandwidths or use more bandwidth-efficient transmission schemes. According to the Shannon Theorem, channel capacity scales directly with bandwidth. To provide sustainable data rates over the air, designers must implement special mechanisms in protocol for faster link adaptation, higher-order modulation, and channel-coding schemes.

Transceiver-design teams are looking for cost-effective ways to test their designs to pass the technical requirements that the standards impose. In the past decade, the advent of faster and better ADCs and DACs, faster and cheaper DSP technology, and integrated RF (radio-frequency) modules have resulted in increasing the performance specifications of test-and-measurement equipment. This article highlights some approaches designers can take when making the price/performance trade-offs with spectrum analyzers.

Dynamic range—the difference between the highest and the lowest power signals that you can simultaneously measure on a spectrum analyzer—is a key gauge of the instrument’s performance. The dynamic range affects the adjacent-channel response, spurious response, and other key regulatory measurements. Dynamic-range performance combines the distortion and noise-floor performance of the spectrum analyzer. It is important

to evaluate the dynamic-range performance of the analyzer in the context of the application or the standard in which the analyzer will find use. Understanding the measurement requirement from an application standpoint could potentially save costs in the purchase of test-and-measurement instruments and may improve test margins and productivity.

A combination of air-interface standards and regulatory bodies, such as the Federal Communication Commission, dictates the performance requirement for a generic transmitter (Figure 1). The specifications that relate to spectral purity, including spectral emissions, adjacent-channel-power ratio, and alternate-channel-power ratio, are critical for transmitter designers. Table 1 presents an example of a system-level-transmitter-emission specification. The table also attempts to use system-level specification and deduce subsection-level specifications. Some sections of the radio have more stringent specifications

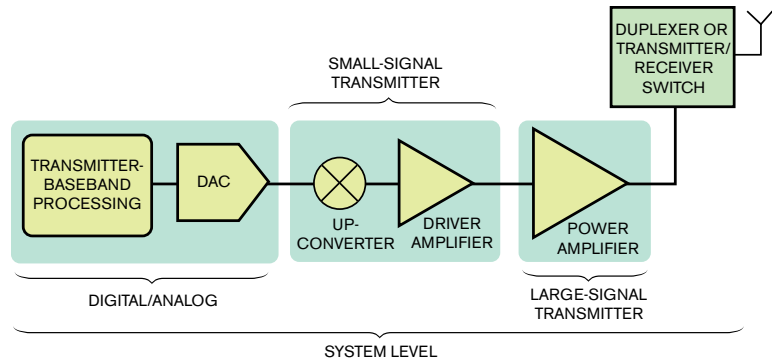

Figure 1 A combination of air-interface standards and regulatory bodies, such as the Federal Communication Commission, dictates the performance requirement for a generic transmitter.

TABLE 1 DYNAMIC-RANGE SPECIFICATIONS

Specification	Standards body/FCC	System level	Power-amplifier level	Transmitting	Digital/analog
Power level (dBm at 10-MHz bandwidth)	33	33	34	20	-10
7-MHz offset	-58	-58	-61	-68	-71
25-MHz offset	-70	-70	-73	-80	-83

that require better performing instruments to make these measurements. The transmitter signal at the output of the digital/analog module typically has the strictest spectral performance requirements and requires analyzers with the best dynamic-range performance.

Spectrum analyzers target specific price-performance points, and you can classify them as having low, economy, midrange, and high performance. The manufacturer's data sheet provides key specifications to determine whether a spectrum analyzer can meet the measurement requirements. The dynamic-range chart lists these specifications, including displayed-average-noise level, third-order intercept, and second-order-harmonic intercept (Figure 2).

DYNAMIC RANGE

The major factors that help quantify a swept-spectrum analyzer's dynamic range are distortion performance, broadband-noise floor, and the phase noise of the local oscillator (Figure 3). The distortion performance includes third-order intercept and second-order-harmonic intercept. The front-end mixer in the analyzer typically dominates this specification. Broadband-noise floor refers to the sensitivity floor of the analyzer. This article takes a closer look at how each one of the above factors affects the spectrum analyzer's dynamic range. A complete discussion on how the spectrum analyzer works is beyond the scope of this article; however, references 1 through 3 provide more detail.

The input section of the analyzer has an RF attenuator; a preselector or a lowpass filter; a mixer, which downconverts the RF to IF (intermediate frequency); and an IF amplifier whose gain couples with the input attenuator. The mixer's second-harmonic distortion and third-order intercept determine the analyzer's distortion performance. The spectrum analyzer's data sheet provides these figures at different measurement frequencies. It also provides a graphical representation for different input levels to the mixer. The mixer input level in decibels referred to milliwatts is the difference between the input signal you apply to the analyzer and the RF-input-attenuation level. For measurements at RF and microwave frequencies, the third-order intermodulation products fall inside the band of interest and thus dominate most spectral measurements. The third-order-distortion products follow the $2 \times F_1 - F_2$ and $2 \times F_2 - F_1$ rule (Figure 4). You can generally ignore the sec-

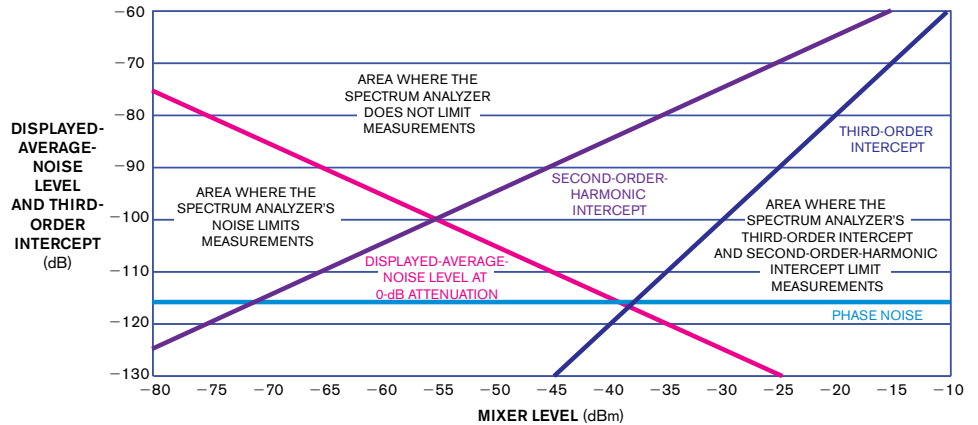

Figure 2 The dynamic-range chart lists these specifications, including displayed-average-noise level, third-order intercept, and second-order-harmonic intercept.

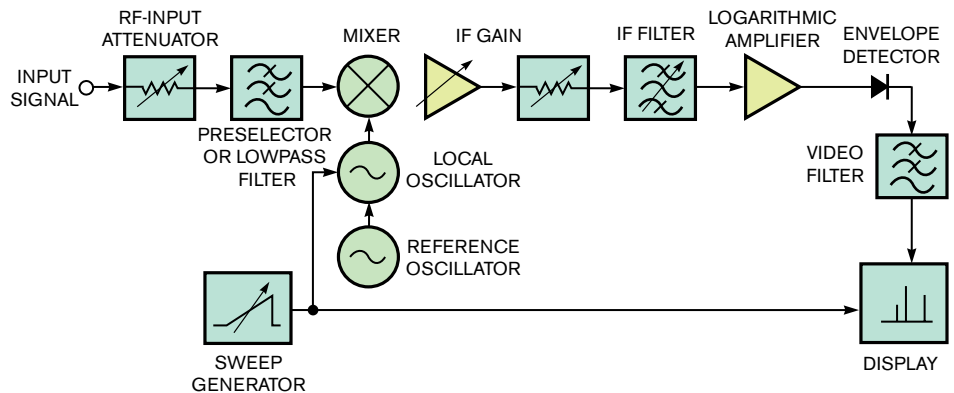

Figure 3 The major factors that help quantify a swept-spectrum analyzer's dynamic range are distortion performance, broadband-noise floor, and local-oscillator phase noise.

ond-order products when the measurement bandwidth is less than twice the fundamental frequency. In general, the odd-order products fall at close proximity to the measurement frequency, and the even-order products fall at multiples away from the frequencies of interest. Typically, the third- and fifth-order intermodulation products of active components such as mixers and amplifiers tend to dominate the ACPR (adjacent-channel-power-ratio) measurements. RF designers must measure the true distortion performance of the device under test. For the ACPR measurement to reflect the true performance of the device under test, the distortion within the analyzer must be significantly lower. As a point of reference, if the distortion performance of the analyzer is 18 dB lower than the device under test, measurement uncertainty will be less than 1 dB (Reference 4).

By reducing the input-signal level to the analyzer's mixer, you reduce the levels of the third-order-distortion products by a factor of two. You can achieve lower levels to the mixer by increasing the analyzer's input-attenuation level. However, increasing the attenuation directly affects the noise floor, reducing the dynamic range. Therefore, the optimal attenuator setting becomes a trade-off between third-order intercept and noise-floor performance. Although two-tone analysis may

seem too simplistic for most digital-communication formats, it can serve as a useful starting point because you can use a summation of tones to represent wide-bandwidth signals (Figure 5). When you look at them in this way, you can easily see that the third-order-intermodulation products are within one main-channel bandwidth away from the carrier—that is, in the adjacent channel. Likewise, the fifth-order products fall within two main-channel bandwidths away—that is, in the alternate channel. With this simplified view, it is immediately obvious that, at different offsets from the main channel, different factors affect the measurement.

The spectrum analyzer's data sheet specifies displayed-average-noise level, which is a measure of the ultimate sensitivity of the spectrum analyzer. Manufacturers typically specify this figure with 0-dB input attenuation and normalized to a 1-Hz resolution bandwidth. The noise floor of the analyzer increases decibel for decibel as the input attenuation increases. As you increase the resolution bandwidth of the filter, the noise floor of the analyzer increases to 10 times the logarithm of the ra-

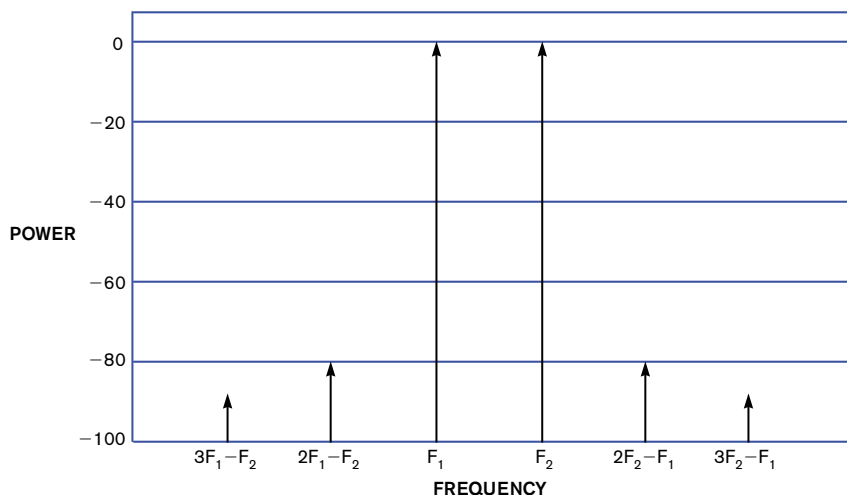

Figure 4 For measurements at RF and microwave frequencies, the third-order-intermodulation products fall inside the band of interest and thus dominate most spectral measurements. The third-order-distortion products follow the $2 \times F_1 - F_2$ and $2 \times F_2 - F_1$ rule.

tio of the resolution-bandwidth increase, and the sweep time decreases, speeding the measurement. This mechanism allows engineers to trade off dynamic-range performance for measurement time. Using the dynamic-range chart helps you determine the optimal mixer-input and attenuation levels. The

intersection of third-order intercept and noise-floor sweep provides the optimal mixer-input level for maximizing dynamic range. This optimized mixer-input level provides a trade-off between noise floor and distortion performance (Figure 6).

To further improve the dynamic-range performance, some spectrum analyzers apply averaging and trace-math calculations to subtract the analyzer-generated noise from the measurement. In practice, noise correction can provide as much as 10-dB improvement in noise-floor performance. Noise correction has two main benefits. One is the ability to subtract the noise contribution of the analyzer from a noise-limited measurement. The second is to allow the user to apply additional attenuation to decrease the internal third-order intercept of the analyzer without increasing the noise floor for third-order-intercept-limited measurements.

PROBLEMS WITH PHASE NOISE

The phase noise of the local oscillator in the analyzer can also degrade an analyzer's noise-floor performance at offsets close to

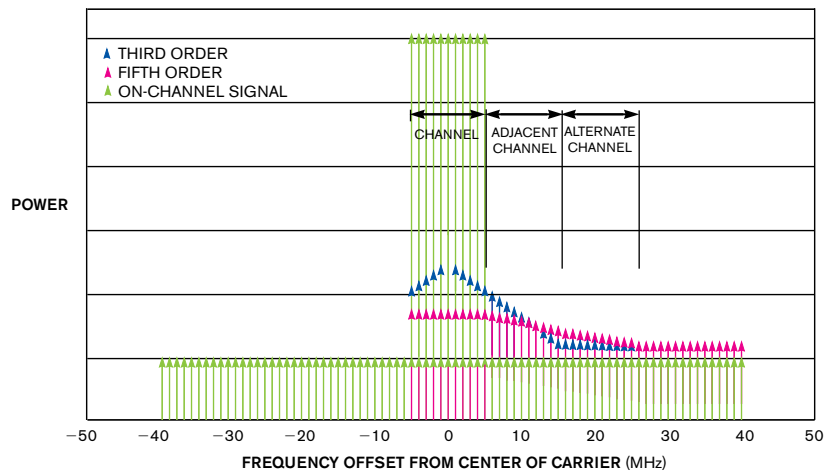

Figure 5 Although two-tone analysis may seem too simplistic for most digital-communication formats, it can serve as a useful starting point because you can use a summation of tones to represent wide-bandwidth signals.

the carrier. In general, at offsets greater than 1 MHz, the phase noise does not impact the dynamic-range performance. The following example provides more details. Consider a digitally modulated signal with a channel bandwidth of 10 MHz. The intent is to measure the spectral emissions at an offset of 5.1 MHz

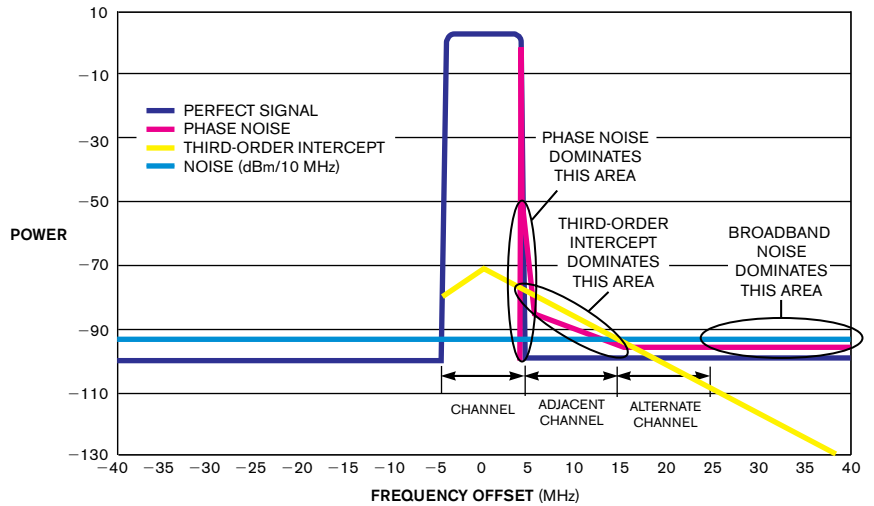

Figure 6 The intersection of third-order intercept and noise-floor sweep provides the optimal mixer-input level for maximizing dynamic range. This optimized mixer-input level provides a trade-off between noise floor and distortion performance.

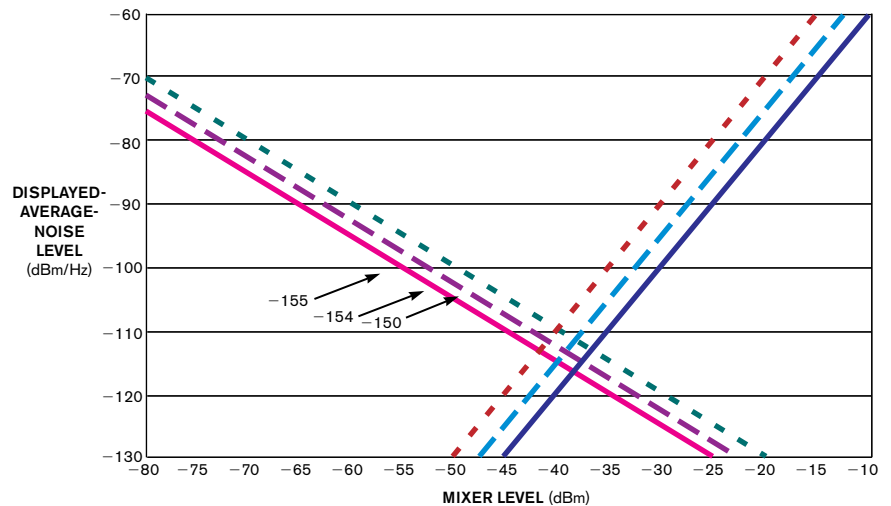

Figure 7 By combining the dynamic-range charts of various analyzers, you can deduce each device's performance limitations.

from the center frequency in a 100-kHz integration bandwidth. The transmitter power is -20 dBm. If you assume that the analyzer's third-order intercept is 19 dBm, the third-order-distortion product is -78 dBc at an integration bandwidth of 10 MHz or -98 dBc at an integration bandwidth of 100 kHz. The 5.1 -MHz offset represents a 100 -kHz offset from the edge of the main channel. Assume that the data sheet documents the phase noise of the analyzer at 100 kHz to be -115 dBc/

Hz. The total noise in the 100 -kHz bandwidth is then -115 dBc + 50 dB = -65 dBc/100 kHz. For close-in offsets, the analyzer has a 65 -dB dynamic range. At offsets more than 1 MHz away, the phase noise of the analyzer improves and does not represent a limitation for dynamic range.

You can apply the basic understanding of the dynamic-range chart to the measurement requirements for the transmitter system in **Figure 2** and **Table 1**. You must use external at-

MORE AT EDN.COM ▶

Go to www.edn.com/ms4281 and click on Feedback Loop to post a comment on this article.

tenuators to protect the spectrum analyzer if the power from the device under test is above the maximum power level that the analyzer specifies. The goal of this exercise is to present customers with the ability to select the spectrum analyzer that meets their measurement needs.

By combining the dynamic-range charts of various analyzers, you can deduce each device's performance limitations (**Figure 7**). Remember that the most stringent requirements are on the digital/analog module. So, a high-performance analyzer would be the best fit for this application. It is important for customers to also look at other specifications, including maximum frequency range, error-vector-magnitude floor, amplitude flatness, and analysis bandwidth, before deciding which spectrum analyzer to purchase.**EDN**

REFERENCES

- 1 "Spectrum Analyzer Basics," Agilent Technologies, Application Note 150, No. 5952-0292, 1989, <http://cp.literature.agilent.com/litweb/pdf/5952-0292.pdf>.
- 2 "8 Hints for Better Spectrum Analysis," Application Note 1286-1, No. 5965-7009E, 2005, <http://cp.literature.agilent.com/litweb/pdf/5965-7009E.pdf>.
- 3 "Spectrum Analyzer Measurements and Noise," Application Note 1303, No. 5966-3319E, 1998, <http://cp.literature.agilent.com/litweb/pdf/5966-4008E.pdf>.
- 4 "Optimizing Dynamic Range for Distortion Measurements," Product Note, literature number 5980-3079EN, 2000, <http://cp.literature.agilent.com/litweb/pdf/5980-3079EN.pdf>.

AUTHORS' BIOGRAPHIES

Satish Dhanasekaran has a master's degree in electrical engineering from Florida State University (Tallahassee, FL). He has more than eight years of experience in the RF/wireless industry. He currently works as a wireless-application specialist with Agilent Technologies Inc.

Darrin Russell has a bachelor's degree in electrical engineering from the University of Texas—Arlington. He has more than 10 years of experience in the RF/wireless industry. Currently, he works as a wireless-application specialist with Agilent Technologies Inc.