



BY PAUL RAKO • TECHNICAL EDITOR

PAY CAREFUL ATTENTION TO ANALOG SWITCHES AND MULTIPLEXERS, WHICH ARE CRITICAL COMPONENTS OF THE SIGNAL PATH. DESIGNERS SHOULD UNDERSTAND THE APPLICATIONS AND SPECIFICATIONS OF THESE IMPORTANT ANALOG PARTS.

# USE ANALOG SWITCHES TO MULTIPLEX YOUR SIGNALS

Few IC-schematic symbols are simpler than the one that depicts an analog switch (**Figure 1a**). A basic switch comprises just an input, an output, a control pin, and a couple of power-supply pins. Yet, bedazzling complexity hides behind this simple appearance (**Figure 1b**). Several specifications, including power-supply voltage and on-resistance, are fundamental to the part's operation. An analog switch also has many ac specs, such as bandwidth and switching time. All these specs, including leakage current, change—sometimes radically—over temperature. As with all other analog parts, the switch has specs that all interact and lie along a continuum of values. These specs are not black and white, just shades of gray (**Reference 1**).

One analog switch is complex, but groups of them that you gang together or integrate into one IC to provide DPDT (double-pole/double-throw) functions or multiplexers are even more complex. For example, a multiplexer that feeds signals to an ADC should be a break-before-make device—that is, it should break contact before it makes contact, keeping the input signals from short-circuiting each other. But a multiplexer on an audio output may need to be a make-before-break device—that is, it must make contact before it breaks contact to prevent objectionable clicks or pops

in the audio signal. As with all analog parts, things are more complicated than they seem at first glance.

## FINDING NEW USES

Analog switches have always had a place in instrumentation and industrial markets. Data-acquisition cards reroute the analog inputs to provide many channels of measurement that travel to an ADC, and they route analog outputs to connectors or internal circuit nodes. The analog switches and multiplexers in these cards have traditionally been high-voltage parts, in keeping with their

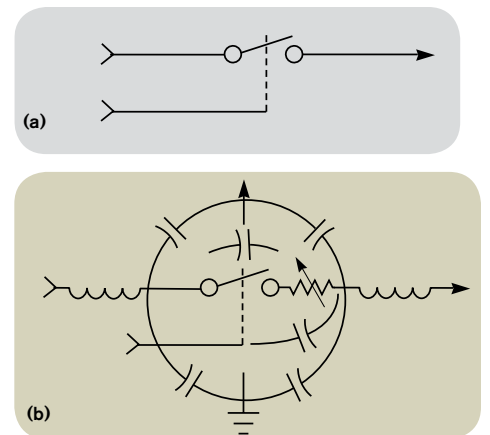

**Figure 1** A simple symbol represents an analog switch, but stray capacitances abound and small inductances occur because of the presence of bond wires (a). The on-resistance is variable with applied signal and power supply, and the capacitors also change with applied voltage (b).

industrial, military, and medical heritage. These decades-old applications will always be with us, but several new technological developments are making dramatic use of analog switches.

One of the highest volume uses of analog switches is in cell phones and other handheld consumer devices. “I don’t

know of a cell phone that does not have at least one switch in it,” says Jerry Johnston, Fairchild Semiconductor’s product-line director for switch products. Size and features are the driving factors in the use of analog switches in phones. Phone cases have little room for connectors, meaning that analog switches must route signals from multiple ICs to one USB port, video port, audio port, or power connector. These switches also have a plethora of features, further increasing their use in cell phones. A basic cell phone typically comprises a baseband IC and the RF-signal chain. A full-featured phone may also include a digital camera and a videocamera, both with associated flash systems, and can serve as an MP3 and video player. It also provides for USB, Bluetooth, and wireless-LAN connectivity. Johnston knows of some high-end cell phones with as many as 14 analog switches.

For similar reasons, another growing application for analog switches is in laptop computers. Even bare-bones laptops have cameras, IR (infrared) ports, Bluetooth, and wireless functions. Also similar to cell phones, laptop computers have a limited amount of outside surface on which to put connectors. Although less severe than the space restrictions for cell phones, this limitation still provides many applications for analog switches.

Home entertainment is another high-volume application for analog switches. Anyone who has had to hook up a TV, a DVD player, a stereo receiver, a gaming system, a cable system, and a computer can attest to the video- and audio-signal-routing challenges that these tasks entail. As with cell phones, these home-entertainment systems may use some digital signals, but you still must use analog switches to route this equipment. For example, many home-entertainment systems have multiple HDMI (high-definition-multimedia-interface) digital-signal paths, and these products need analog switches to route those signals because using digital switches can cause skew and delay. A digital switch creates one or more gate delays as it functions, and those delays may be non-deterministic, instead changing with switch routing or temperature, and the gates’ rise and fall times may change the duty cycle of the digital signal.

Yet another high-volume application

### AT A GLANCE

▣ The key specs for analog switches are voltage, on-resistance, capacitance, charge injection, speed, and package.

▣ Dielectrically isolated processes prevent latch-up in some switches.

▣ Switches can work from dc to 400 MHz and beyond.

▣ MEMS (microelectromechanical-system) switches work well at high frequencies but have reliability problems and expensive packaging.

▣ Be sure to model all the parasitic elements if you are simulating an analog switch.

of analog switches is automotive entertainment, which has all the same signal-routing problems as, but with less space than, a home-entertainment system. Automotive electronics, or “telematics,” combine the signal-routing and management challenges of the entertainment, computer, and cell-phone environments.

### IMPORTANT SPECS

How much voltage an analog switch can withstand is just as critical as the voltage rating on a mechanical switch, sometimes indicating the switch’s intended market. Switches with voltages of 12 to 36V often target the instrumentation, military, and medical markets. Data-acquisition systems that must measure some unknown voltages from the outside world also benefit from using analog switches with high voltage ratings. Because designers have no control over the level of the measured voltages, it is important for the switch to be able to

handle as much voltage as possible. It is this same quest for robustness that led to the development of dielectrically isolated and fault-protected analog switches.

Dielectric isolation puts each transistor in the IC in its own glass enclosure (**Figure 2** and **Reference 2**). Glass has a lower dielectric constant than silicon, yielding very low internal capacitance for dielectrically isolated parts. As a result, the formation of a parasitic SCR (silicon-controlled rectifier) can cause latch-up in the IC substrates if an input signal goes outside the power-supply rails (**Figure 3**). Manufacturers typically fabricate parts for consumer electronics on inexpensive CMOS process, and these parts have maximum voltage ratings of 5.5V. For example, Fairchild’s FSA2270T dual-SPDT (single-pole/double-throw) analog switch swings below the negative rail so that it can pass bipolar-audio signals when it has no negative-power-supply rail (**Reference 3**). Another example, Texas Instruments’ TS3USB221 multiplexer/demultiplexer switch, operates from a 2.3V supply.

Fault protection is another important spec. Devices with this feature incur no damage even if the input-voltage exceeds the power-supply rails. The Maxim MAX388 analog multiplexer, for example, has fault protection to 100V. In addition to providing internal fault protection, your circuit can be designed to protect analog switches for overvoltage conditions (**Reference 4**).

On-resistance is another vital spec of an analog switch. On-resistance may seem unimportant if your design includes an operational amplifier that provides buffering to the analog switch. The op amp’s input impedance may be in the megohms, so putting a 100Ω

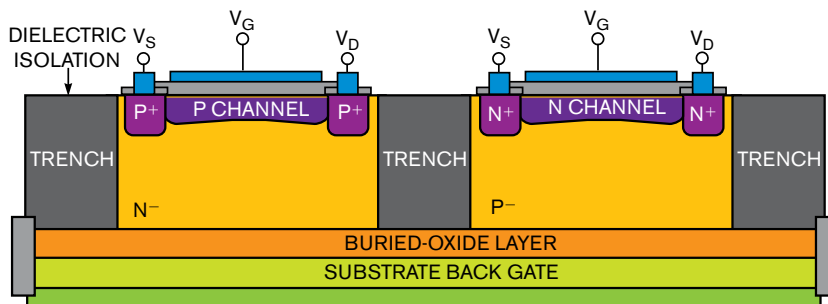
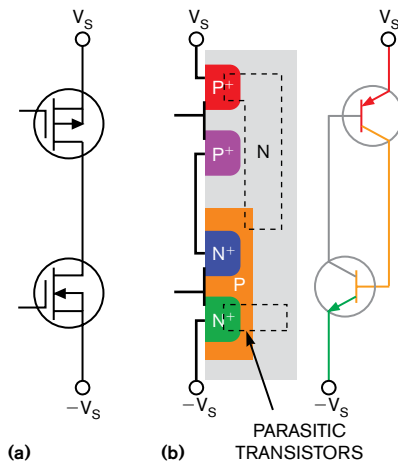

Figure 2 The dielectrically isolated process isolates each transistor in an IC with an oxide trench. This approach prevents latch-up and lowers stray capacitance (courtesy Analog Devices).

analog switch in series with the input means that this impedance is negligible, but only at dc. The on-resistance of the switch can react to the stray capacitance and input capacitance of the amplifier. This reaction can create a pole that rolls off the frequency response of the signal chain, perhaps to unacceptable levels. Many other signal-routing applications need far lower on-resistance. Whereas  $100\Omega$  was acceptable decades ago when engineers used Fairchild's ubiquitous CD4066 CMOS analog switch, many devices' on-resistances soon decreased to  $10\Omega$ , and several less-than- $1\Omega$  analog switches are now available. For example, the Pericom PI3A3159 SPDT analog switch has an on-resistance of  $0.4\Omega$ . These new parts reach low on-resistances at operating voltages as low as  $2.7V$ .

Another specification of importance, off-resistance, measures the switch's ability to block a signal. The fundamental off-resistance of an analog switch is the off-resistance of a MOS transistor, which is usually higher than most circuits need. The off-resistance is also a function of the ESD (electrostatic-discharge)-protection diodes that are on the IC die to prevent damage in handling and assembly of the transistors (Figure 4). It may help to think of off-resistance as a leakage specification. Because leakage doubles with every  $10^\circ C$ , you should always check the off-resistance at the maximum temperature at which you expect your circuit to operate. Also, off-resistance and leakage are specifications that apply at dc or low frequencies. At higher frequencies, switch capacitance dominates off-resistance and leakage.

Capacitance is unavoidable in anything as small as a modern analog switch. The pins are close together, so you can expect a few picofarads of coupling between them. You must also contend with the capacitance between the transistor structures and the substrate. Manufacturers fabricate modern parts on proprietary processes so that the parts can operate into the RF range—easily hundreds of megahertz. Some customers ask manufacturers to specify analog switches with insertion and return losses, specs associated with RF design, according to Manav Malhotra, an associate business manager at Maxim Integrated Products. Semiconductor analog switches also have an Achilles' heel:



**Figure 3** Chip designers use P- and N-channel FETs in CMOS ICs (a). When the inputs to the transistor exceed the power-supply rails, latch-up conditions occur. This excursion causes free carriers in the substrate, which triggers the creation of a parasitic silicon-controlled rectifier (b). This excursion also shorts the positive-supply voltage to the negative-supply voltage.

the capacitance between various pins and to ground or power. Reed relays and MEMS (microelectromechanical-system) switches have smaller stray capacitance, making them suitable for frequencies well into the gigahertz range, but both relays and MEMS are mechanical devices and will wear out with hundreds of thousands to millions of cycles. Reed-relay switches also need a lot of power to actuate, and MEMS devices require expensive packaging to keep the silicon beam in a hollow area so that it can operate. Even if your signals are only hundreds of kilohertz, you should look at the analog switch's capacitance between pins, including ground and power, to decide whether the part will provide the needed isolation and crosstalk specifications.

Charge injection is another important specification in analog switches. Turning on a switch tends to inject charge into the signal path, which can be catastrophic in sample-and-hold regulators and in multiplexers that feed an amplifier. IC designs that match internal capacitance inside the part can minimize charge injection. The faster the rising edge on the actuating signal, the more of a problem that charge injection will be. Lowering the slew rate of the ana-

log-switch control signal may reduce the charge injection to acceptable levels. Be sure to evaluate this factor if your design has any high-impedance nodes in the signal path. Charge injection is often a cause of pops and clicks in audio circuits that incorporate analog switches. As with all specs, check this factor over the temperature at which you expect your design to operate.

Many analog switches route fast digital signals, so the speed of actuation is an important spec for many users. Even in legacy applications, such as data-acquisition multiplexers, you must factor in the speed of the switch to the sample-and-hold analysis to ensure that the signal has settled to an accurate level before the ADC measures it. You should also note the PSRR (power-supply-rejection ratio) of any analog switches in a signal chain. Just as the capacitance between outputs and power can attenuate a fast signal, that same capacitance can pass a high-frequency noise component on the power rail into your output signal. These days, switching power supplies power many analog circuits. Be sure to examine the spectral content of the power rail. If frequencies are high enough, they will pass into your design's output through the internal capacitance in the analog switch. Placing a resistor or an inductor in series to the power-supply pin of the part and one or more decoupling capacitors close to the analog switch ensures that noise from the power supply does not enter your design's signal path. It will also make the circuit more immune to RFI (radio-frequency interference, Reference 5).

A spec that may be as important as any other is the package the part comes in. If you are designing a handheld instrument or a cell phone, you need your device to fit into an SC-70 or a smaller package. If you are using the part to switch power, then you may want a large package to aid in the power dissipation to keep the part from becoming too hot. Another package consideration is conformance with a standard part's pinout. If you need to upgrade an Intersil DG403 monolithic analog switch, for example, then you need a part that uses an identical package and pinout. Getting a part with low on-resistance in a small package is a challenge. "The challenge with most switches is physics," says Jeffery

DeAngelis, executive director of the interface-switch-and-protection-business unit at Maxim Integrated Products. “To get a smaller on-resistance, you parallel multiple fingers [gate structures] in your FET. When you do that, you get lower on-resistance, but the die grows.”

Current consumption is yet another critical parameter. Some parts change supply current depending on the level of the control signal you apply to them. Evaluate supply current on a breadboard; don’t assume that the nominal figure on the data sheet applies to your circuit. Also be aware that the supply current changes over temperature.

## HANDLING TRADE-OFFS

With so many specs to consider, it would behoove a diligent analog engineer to examine the basic trade-offs inherent in analog switches. All engineers know that the most important spec is price. For a low-cost switch, you can’t beat an old CD4066 CMOS analog switch. It works at voltages as high as 15V, and you can use more than one switch in parallel to achieve a reasonable level of on-resistance. At the other end of the spectrum, the dielectrically isolated Intersil HS-303ARH has a radiation-hardened silicon gate that makes it suitable in military and satellite applications. Another trade-off involves supply voltage. In general, a higher power-supply voltage means a lower on-resistance. For example, STMicroelectronics used a new process when fabricating the STG3699B quad-SPDT switch, giving it an on-resistance of 0.5Ω.

Another trade-off is power-supply current. A device that operates at high speeds requires a higher supply current to slew the transistor gates at a faster rate. CMOS or DMOS analog switches often have low power-supply current. For example, STMicro’s STG3684 SP-DT switch uses only 200 nA. This current rises with temperature. The com-

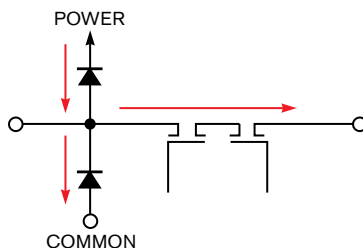

Figure 4 Leakage currents into a pin usually establish the off-resistance of an analog switch. This leakage comprises the leakage through the switch FETs and mismatch in the ESD-protection diode’s leakages.

pany specifies some parts, such as the STG3689, at 85°C.

Other trade-offs include the size and power dissipation of the package. Switching-power designs require a larger package, which in turn may require a low on-resistance, because the bigger the die, the lower the resistance. Novel processes and circuit techniques have provided for remarkable strides in this area, as well. Vishay now offers 14 switches with on-resistances of less than 1Ω. Yet, these parts come in packages as small as SC-70 with a 3×2-mm footprint.

One trade-off that you may overlook is the change in on-resistance with the applied signal. If you use a high-voltage power supply and a small signal swing, then this change may not be a problem. If your signal swings rail to rail to the supply voltage, however, you will need a newer device that provides uniform on-resistance over the passed signal voltage.

CMOS analog switches tend to be cheaper but run on lower voltages. DMOS switches have higher voltages and switch faster. The DMOS switches generally have more stringent drive requirements. Vishay has developed the DG611 switch, which uses both CMOS and DMOS to achieve the benefits of both processes (Reference 6). One thing that distinguishes analog-switch makers is the ability to provide for custom or proprietary processes such as Analog Devices’ 35V iCMOS process, which tailors the part for specific applications, according to Liam Ó Súilleabháin, a product manager at the company. “If you compare the ADG408 to our new product, the ADG1408, the 408 has an on-resistance of 100Ω, whereas the 1408 has an on-resistance of 4.7Ω. [The company offers] the 1408 in the

same TSSOP package but also has another package option, the LFCSP, which is 70% smaller.”

MEMS parts may involve a future trade-off for analog switches. The problems now are mechanical reliability and price. MEMS switches are mechanical, and, although you can expect them to be more reliable than a reed-relay switch, they can still wear out or fail catastrophically. Also, you must keep the MEMS structure away from the encapsulating epoxy, so MEMS packaging is always more expensive than silicon-analog-switch packaging. In addition, MEMS switches take longer to switch because they are mechanical.

Looking at the myriad applications and multifaceted specifications of analog switches, you can see that there is more than meets the eye with these ubiquitous little parts (Reference 7). Be sure to understand their uses and specifications when you design your next signal chain. If you are doing a Spice simulation that includes an analog switch, be sure that the model is complete, showing parasitic and stray capacitances and bond-wire inductance. Many Spice models cannot account for charge injection or on-resistance change with applied voltage. Don’t be surprised if the breadboard shows problems that the Spice run does not. Check everything over temperature and make sure that the part you have selected is available and will be in production for the life of your product. If you properly apply analog switches, you can achieve features and cost reductions that you cannot get in any other way. **EDN**

## FOR MORE INFORMATION

**Analog Devices**  
www.analog.com  
**Fairchild Semiconductor**  
www.fairchildsemi.com  
**Intersil**  
www.intersil.com  
**Maxim Integrated Products**  
www.maxim-ic.com

**Pericom**  
www.pericom.com  
**STMicrosystems**  
www.st.com  
**Texas Instruments**  
www.ti.com  
**Vishay**  
www.vishay.com/  
analog-switches

## MORE AT EDN.COM

➤ For a list of the references cited in this article, go to the Web version at [www.edn.com/080612df](http://www.edn.com/080612df).

➤ Go to [www.edn.com/080612df](http://www.edn.com/080612df) and click on Feedback Loop to post a comment on this article.

You can reach Technical Editor **Paul Rako** at 1-408-745-1994 and [paul.rako@edn.com](mailto:paul.rako@edn.com).

