

# designideas

READERS SOLVE DESIGN PROBLEMS

## Precision temperature controller has thermal-gradient compensation

W Stephen Woodward, Chapel Hill, NC

Accurate and stable temperature control is necessary for effectively using many thermally sensitive components and sensors, such as semiconductor lasers and optical detectors. An industry has grown up in response to provide thermal-control devices, such as TECs (thermoelectric coolers), temperature sensors, and both monolithic and hybrid application-specific driver ICs, to facilitate the associated designs. This availability eases the implementation of high-performance thermostasis electronics with good dynamic behavior, because it allows you to assemble feedback loops with flexible and sophisticated control characteristics—PID (pro-

portional-integral-differential) feedback loops, for example—with nothing more than appropriate choices of shunt resistance and capacitance. Unfortunately, achieving good static stability is sometimes more difficult because the thermal properties of a system, rather than the electronics, often cause limited temperature-control-loop static stability.

Every thermal-control system incurs nonzero thermal impedances in the heat-transfer paths between the source of heating, cooling, or both. These paths include the thermal load, which is the object of thermostasis; the temperature sensor—the thermistor, for example; and the ambient

### DI Inside

70 Programmable current source requires no power supply

72 Pulse-width modulator has digital control

74 Microcontroller controls analog phase shifter

74 Composite instrumentation amplifier challenges single-chip device for bandwidth, offset, and noise

► What are your design problems and solutions? Publish them here and receive \$150! Send your Design Ideas to [edndesignideas@reedbusiness.com](mailto:edndesignideas@reedbusiness.com).

temperature. If the ratios of these impedances don't balance well, which, unfortunately, is usually the case, then

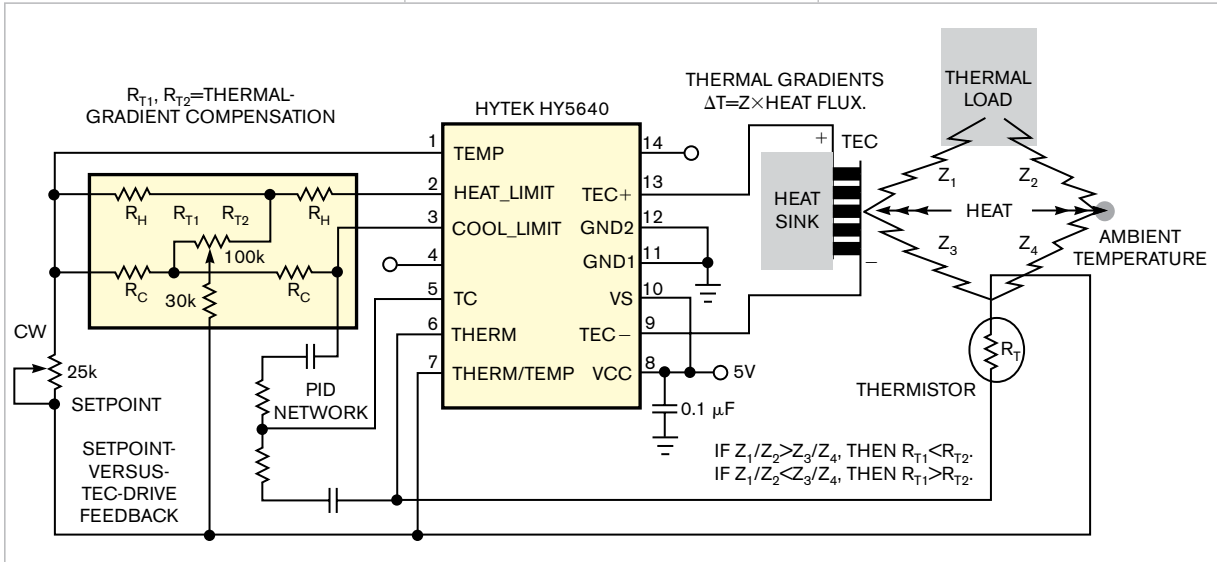

Figure 1 This circuit partially cancels the effects of thermal gradients in the load's thermal impedances. It works by providing an adjustable positive- or negative-feedback path from the TEC-drive level that couples changes in ambient temperature into compensating changes in the thermistor setpoint.

even perfect thermostasis of the sensor doesn't equate to adequate stability of the load's temperature (Figure 1).

For example, if  $Z_1/Z_2$  is greater than  $Z_3/Z_4$ , where  $Z$  is the impedance, then rising ambient temperatures will cause the temperature of the load to rise, whereas falling ambient temperatures will cool the load. By contrast, if  $Z_1/Z_2$  is less than  $Z_3/Z_4$ , then rising ambient temperatures will cause the temperature of the load to fall and vice versa (Figure 2). Reducing the parasitic impedances with tighter thermal coupling and better insulation can reduce but seldom eliminate the gradient and magnitude of the error.

The circuit in Figure 1 provides a different solution: an electronic workaround to at least partially cancel the effects of thermal gradients in the impedances. It works by providing an adjustable positive- or negative-feedback path from the TEC-drive level that

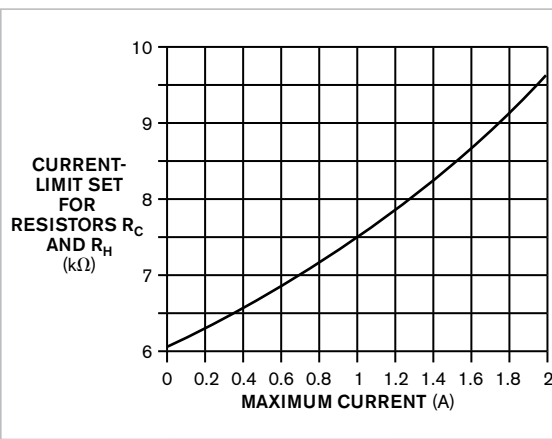

Figure 2 The TEC's maximum-drive heat- and cool-current ratings determine the selection of current-sampling resistors  $R_C$  and  $R_H$ .

couple changes in ambient temperature and, therefore, in TEC drive into compensating changes in the thermistor-setpoint temperature. The implementation in Figure 1 uses a popular hybrid TEC controller. Two signal nodes that track TEC drive, COOL\_LIMIT and HEAT\_LIMIT, are inputs

to an adjustable bridge circuit that comprises  $R_{T1}$ ,  $R_{T2}$ , the potentiometer, and associated circuitry. With correct adjustment of  $R_{T1}$  and  $R_{T2}$ , a test determined that the thermistor setpoint must move either with or in opposition to ambient temperature, so that net stability of the load results. A version of this concept flew as part of two tunable-diode laser spectrometers in the science package of the 1999 Mars Polar Lander (Reference 1).EDN

REFERENCE

May, Randy D, Siamak Forouhar, David Crisp, W Stephen Woodward, David A Paige, Asmin Pathare, and William V Boynton, "The MVACS tunable diode laser spectrometers," American Geophysical Union, *Journal of Geophysical Research*, Volume 106 (E8), 2001, pg 17,673, [www.agu.org/pubs/#journals](http://www.agu.org/pubs/#journals).

## Programmable current source requires no power supply

John Guy, National Semiconductor, Santa Clara, CA

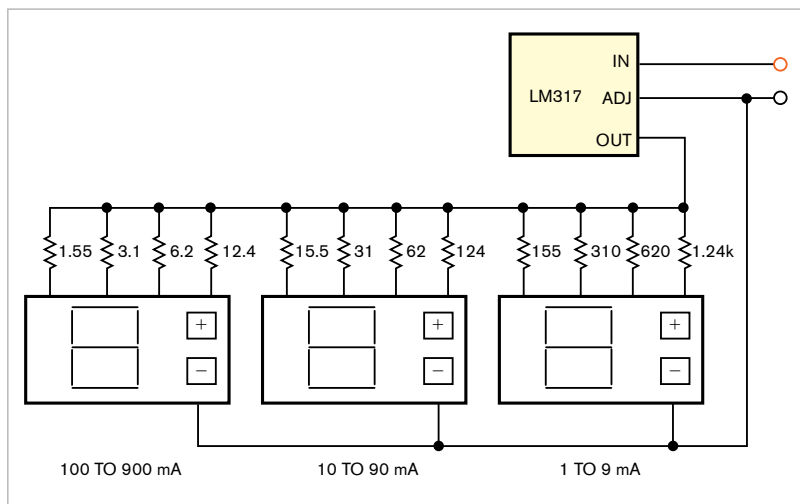

Figure 1 This programmable current source uses BCD switches to set the current limit.

Engineering labs are usually equipped with various power supplies, voltmeters, function generators, and oscilloscopes. One piece of equipment missing from many such labs, however, is a current source. This omission is unfortunate, because a current source is useful for creating I-V (current-versus-voltage) curves, charging and discharging batteries, preloading power supplies, and many other applications.

The circuit in Figure 1 is an easy-to-build, easy-to-use, low-cost current source. It comprises three sections of BCD (binary-coded-decimal) switches, a three-terminal adjustable regulator, a handful of 1%-tolerant resistors, and a National Semiconductor (www.national.com) LM317 three-terminal adjustable regulator. All newer National Semiconductor regulators are of the low-dropout type, which is unsuitable for this application. The switches short their four outputs to a common terminal based

on the digit setting of the switch.

The circuit operates as follows: Assume that the red terminal in **Figure 1** connects to a 5V power supply and that the black terminal connects to the power supply's ground. Assume that the middle digit (labeled 10 to 90 mA) gets set to two and that the other two digits get set to zero. The BCD switch connects a 62Ω resistor from the LM317's output to adjust pins. The LM317 forces 1.25V across the 62Ω resistor, causing 20 mA to flow from the output pin through the resistor, and to the black terminal of the

current source. The circuit maintains this regulation provided that the input voltage remains 3 to 40V.

To construct the current source, you should either use a heat sink for the LM317 or build the circuit into a die-cast aluminum housing, which acts as the heat sink. Isolate the LM317 from the heat sink using a thermally conductive isolation pad and a shoulder washer. You determine the resistors' values by starting with the base-resistance value, 1.24 kΩ. Then, simply use parallel values to determine the successive resistors' values. For example, two 1.24-

kΩ resistors in parallel yield 620Ω, four 1.24-kΩ resistors in parallel yield 310Ω, and so on. Using this approach with ¼W resistors ensures that the highest current resistors do not overheat. For example, eight 12.4Ω, ¼W resistors yield 1.55Ω resistance and dissipate only 1W with a peak capability of 2W.

The performance of the circuit is about 2% accurate. You can achieve higher accuracy with hand-selected resistors. The output impedance for lower currents is more than 1 MΩ but drops to approximately 250 kΩ at 200 mA. **EDN**

## Pulse-width modulator has digital control

S Vinay Kumar, Mysore, India

In this Design Idea, the total time period of an output pulse's width is 16 times the pulse width of the input clock. The input clock connects to a binary counter (**Figure 1**). The output of the binary counter then goes to a decoder. The decoder scans the signal such that the first output of the decoder goes to an inverter gate and then to the counter. The output of the counter then goes to one as soon as the signal to the counter goes from zero to one and then from one to zero.

The multiplexer decodes the output pulse width's time to be in the on state. The first output of the demultiplexer sets the output of the counter, and the next outputs clear the output of the counter. The multiplexer, a 14067, selects the clearing signal. Upon the 0th input of the multiplexer, the PWM (pulse-width-modulator) out-

put becomes zero because the setting time and clearing time become nearly

zero. The last input of the multiplexer does not connect, so the final input selection becomes independent of the PWM output. The design uses all the intermediate input selections of the multiplexer. **EDN**

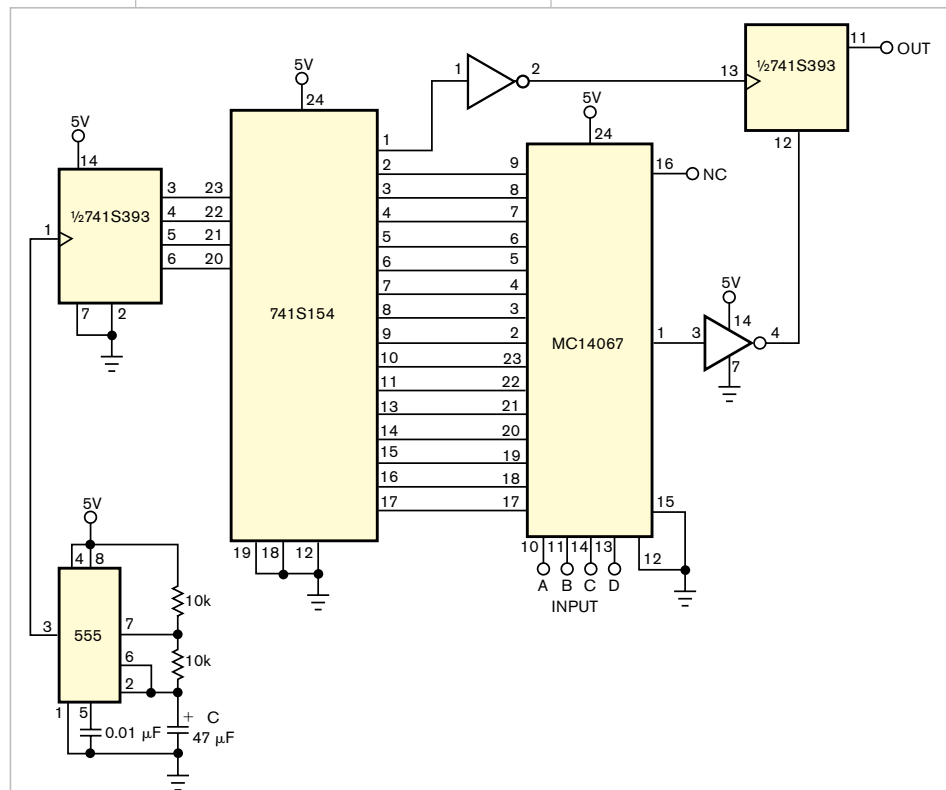

**Figure 1** In this digitally controlled pulse-width modulator, the period of the output is 16 times the pulse width of the input clock.

## Microcontroller controls analog phase shifter

Nick Ierfino, IGS Technologies, Montreal, PQ, Canada

Phase shifters find use in a variety of circuits, but variation in amplifier and capacitance tolerances usually makes it difficult to control the exact phase shift that precise control circuitry requires. The circuit in **Figure 1** can control the phase shift from input to output by using IC<sub>2</sub>, an

AD5227 64-step-up/step-down control digital potentiometer, to replace the value for the resistance. The formula of the center frequency of the output is  $1/(2 \times \pi \times R \times C)$ . Different ranges of resistance are available for the AD5227. This example uses a 10-k $\Omega$  value. By stepping through the

64 points, the 720-kHz input sine wave rotates several times from 0 to 360°. The AD5227 acts as a potentiometer, in which A and B are the extremes and W is the wiper.

This example uses IC<sub>2</sub>, a PIC16F84 microcontroller with a crystal frequency of 20 MHz. This microcontroller has a theoretical potential performance of 5 MIPS and should serve many purposes in PLL (phase-locked-loop) circuitry. You could use any microcontroller or even an FPGA to control the AD5227. **EDN**

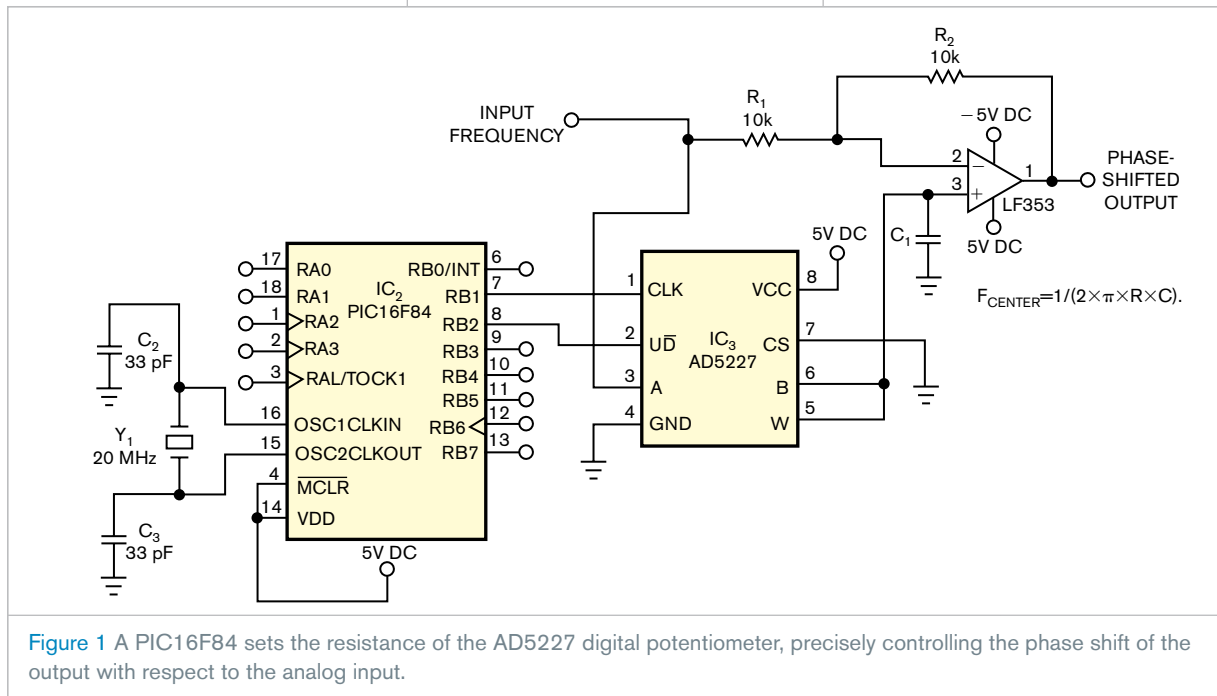

## Composite instrumentation amplifier challenges single-chip device for bandwidth, offset, and noise

Marián Štofka, Slovak University of Technology, Bratislava, Slovakia

Although the prevailing number set in electronics is binary, human-machine interaction uses a decimal-number set. For this reason, designs often require the use of amplifiers with gain programmable in steps in the power of 10. Currently, Analog

Devices' (www.analog.com) AD8253 monolithic instrumentation amplifier is digitally programmable with voltage gains of one, 10, 100, and 1000 (**Reference 1**). This IC has high bandwidth at lower gains, but you inevitably sacrifice this bandwidth when the

amplifier has a gain of 1000. If your application's demands for bandwidth reach the megahertz range at a gain of 1000 and if offset and noise performance prevail over circuit complexity, then a composite amplifier may fill the bill (**Figure 1**).

The composite amplifier is a cascade of three Analog Devices' AD8250 digitally gain-programmable amplifiers IC<sub>1</sub>, IC<sub>2</sub>, and IC<sub>3</sub> (**Reference 2**). The AD8250 is programmable for voltage gains of one, two, five, and 10. Because the gains of one and 10 are the only

ones of interest in this case, the 2-bit words corresponding to these two values of gain are the zero and three in binary code, and the two logic pins of each of these three ICs connect. The AD8250 has a typical bandwidth of 3.8 MHz and a guaranteed bandwidth of 3 MHz at a gain of 10. The net result is that the bandwidth of the amplifier is 1.9 MHz at a gain of 1000, which is more than six times that of the single-chip AD8253. The low-frequency noise is less than 40% of that of the single-chip device. **EDN**

## REFERENCES

1 "AD8253 10 MHz, 20V/ $\mu$ s, G=1, 10, 100, 1000 iCMOS Programmable Gain Instrumentation Amplifier," Analog Devices, 2007, [www.analog.com/pr/AD8253](http://www.analog.com/pr/AD8253).

2 "AD8250 10 MHz, 20V/ $\mu$ s, G=1, 2, 5, 10 iCMOS Programmable Gain Instrumentation Amplifier," Analog Devices, 2007, [www.analog.com/pr/AD8250](http://www.analog.com/pr/AD8250).

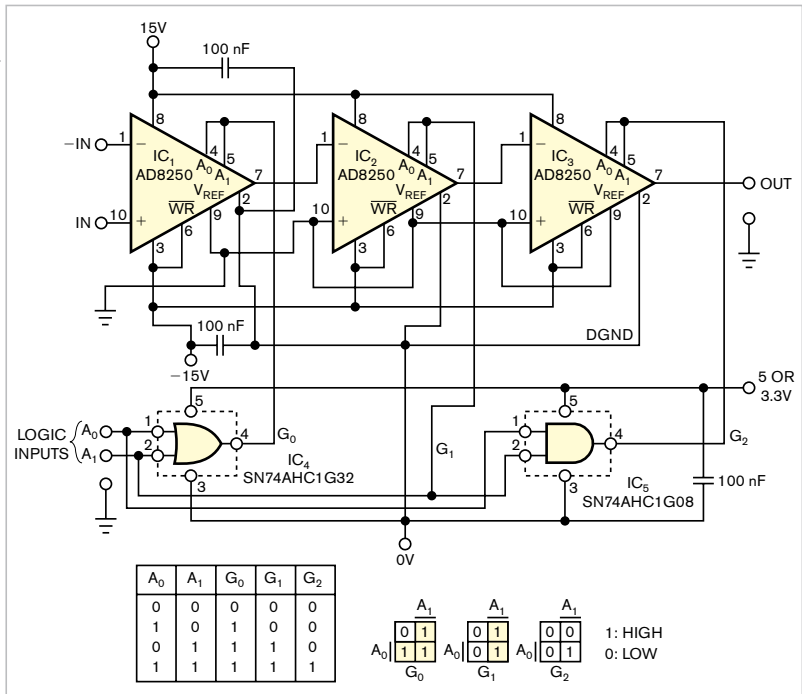

**Figure 1** Although comprising five IC packages, this digitally gain-programmable instrumentation amplifier reaches a typical bandwidth of 1.9 MHz at a gain of 1000 and thus covers the megahertz range at any of the programmable gains of one, 10, 100, and 1000.