

designideas

READERS SOLVE DESIGN PROBLEMS

Low-cost circuit incorporates mixing and amplifying functions

Guus Colman, Guy Torfs, Johan Bauwelinck, and Jan Vandewege, INTEC/IMEC, Ghent University, Ghent, Belgium

▶ In many applications, the frequency-conversion steps comprise a buffer, preferably with some extra voltage gain; a mixer; and some filtering. Instead of including an amplifier in front of the mixer, you can easily integrate the mixer function with the amplifier. A low-cost implementation uses an amplifier with a power-down-disable feature. When a square-wave local oscillator drives the disable pin, a square wave at the oscillator's frequency multiplies the input signal, and frequency conversion takes place.

The circuit in **Figure 1** uses an Analog Devices (www.analog.com) low-cost, 300-MHz, rail-to-rail AD8063 amplifier. The test circuit comprises a noninverting-op-amp circuit, which drives a load of 4 k Ω . The two resistors in the feedback loop regulate the voltage-conversion gain. In the test circuit, the voltage gain is 20 dB. How-

ever, you must consider the switching loss, which is about 10 dB when using an ideal switch and a 50%-duty-cycle clock. This scenario results in a 10-dB voltage-conversion gain.

Because the switching interrupts the power-supply current, the device's turn-on and turn-off times have a non-negligible influence on conversion gain and nonlinearities. The AD8063's turn-on time, at 40 nsec, is less than the turn-off time of 300 nsec. In these cases, more signal power passes to the output, which results in an increase in voltage-conversion gain. **Figure 2** shows the voltage-conversion gain of the test circuit when downconverting an input signal to 12 kHz with a local-oscillator duty cycle of 50%. You can easily adjust this conversion gain by changing the two resistors in the feedback loop.

Another aspect of a mixer's ac performance is distortion. The test circuit

DI's Inside

- 78 Simple blown-fuse indicator sounds an alarm
- 78 Tester cycles system-power supplies
- 80 Touch-activated timer switch extends battery life

▶ What are your design problems and solutions? Publish them here and receive \$150! Send your Design Ideas to edndesignideas@reedbusiness.com.

maintains a second-order harmonic distortion of 35 dB and a third-order harmonic distortion of 43 dB when mixing a 5-MHz signal to a 12-kHz, 1V-p-p output signal. The circuit can downconvert two sine waves of identical power at 5 and 5.002 MHz to 12 and 14 kHz, respectively, with an intermodulation distortion of 47 dB. **EDN**

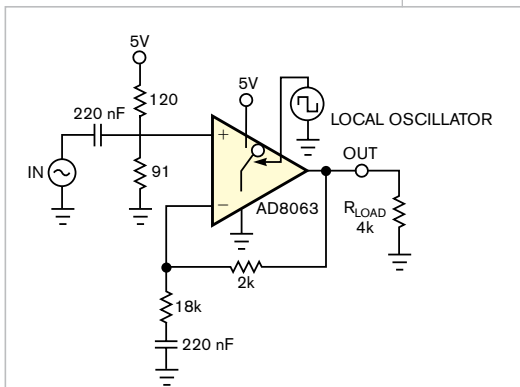

Figure 1 This circuit integrates the mixer function with a noninverting amplifier. The two resistors in the feedback loop set the voltage-conversion gain.

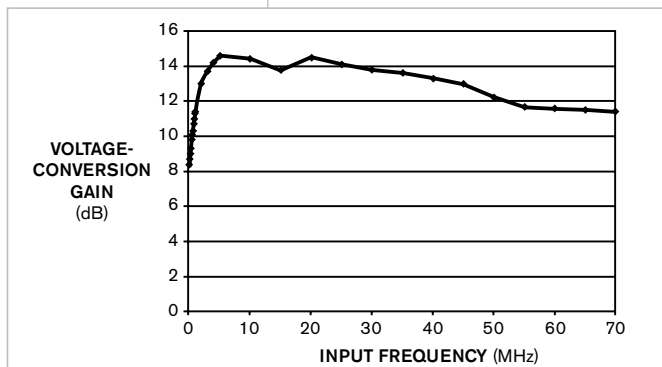

Figure 2 This graph shows the voltage-conversion gain of the test circuit when downconverting an input signal to 12 kHz with a local-oscillator duty cycle of 50%. You can easily adjust this conversion gain by changing the two resistors in the feedback loop.

The system board remains powered up for approximately 45 sec. During the on time, capacitor C_1 discharges slowly through R_2 , Q_2 , and R_8 . C_1 turns off transistor Q_2 once the voltage across

the base of the transistor is below the transistor's turn-on voltage. Then, contact 2_B connects to contact 2_A , and the cycle repeats.

The off time for this circuit should

be approximately 17 sec. Freewheeling diodes D_1 and D_2 reduce the large transient voltages that occur when the currents through the relay coils change quickly. **EDN**

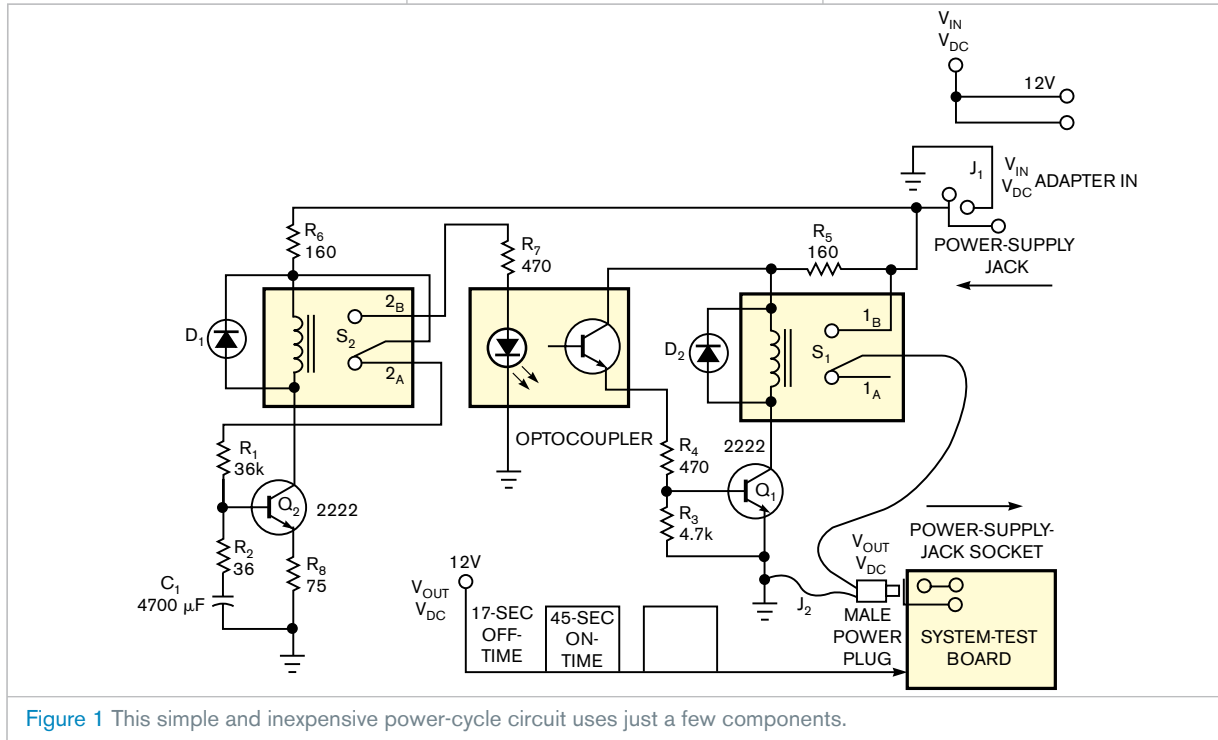

Figure 1 This simple and inexpensive power-cycle circuit uses just a few components.

Touch-activated timer switch extends battery life

Israel Schleicher, Prescott Valley, AZ

▶ A certain type of cordless optical computer mouse operates on two AA alkaline cells. It has no power on/off switch. When not in use, it automatically reduces power consumption by switching its light source on and off at a low duty cycle. Nevertheless, this function unnecessarily drains the battery, and it is annoying to often find the device inoperable. The solution to the problem is to add a battery switch that automatically disconnects the battery after a preset time. This approach requires no disassembly or other kind of tampering. This Design Idea describes two distinct implementations of a touch-activated timer switch that you can add to many battery-operated

gadgets that you might inadvertently leave on.

The circuit in **Figure 1** illustrates an analog implementation of the switch. **Figures 2** and **3** show digital implementations. The idea is to insert a 30-

THIS DESIGN IDEA DESCRIBES A TOUCH-ACTIVATED TIMER SWITCH THAT YOU CAN ADD TO MANY BATTERY-OPERATED GADGETS.

mil-wide strip of dual-sided PCB (printed-circuit board) between the negative pole of the battery and the spring contact of the battery holder (Item A in the **figures**). Q_3 is a low-threshold MOS transistor that connects between the two sides of the strip and serves as the switching element (**Figure 1**). C_1 is a 0603 X7R ceramic-chip capacitor, and R_1 is a 0603 chip resistor. You mount Q_3 and all associated components near the upper edge of Item A. You insert a narrow strip of thin brass, Item B, in series with the positive pole of the second cell. You connect it to the circuit with a piece of thin, flexible wire. Touch contacts C and D comprise short strips of self-adhesive copper tape that you attach outside the battery compartment. Thin and flexible wires connect C and D to the circuit.

Q_1 , Q_2 , and C_1 form a monostable flip-flop. When the switch is off, C_1

does not charge, and both Q_1 and Q_2 are off. When you momentarily touch both C and D with bare fingers, current through your hand charges C_1 to the threshold level of Q_2 . Both Q_2 and Q_1 turn on, discharging C_1 through Q_1 and your conductive fingers. The voltage level at the gate of Q_2 is then close to the battery voltage. After you remove your fingers, the leakage through the internal gate protection of Q_2 —the zener diode in the figures—causes the voltage at the gate of Q_2 to slowly drift lower until it reaches the threshold level of approximately 1.3V. Q_2 exits conduction and, with Q_1 , causes a regenerative action to quickly turn off Q_3 .

The switch remains off until you again touch C and D. Item E is an optional contact similar to C and D. If you touch E and D, the switch turns off. Using a value of $0.01 \mu\text{F}$ for C_1 , you obtain a delay of approximately one hour. Because the gate leakage is on the order of a few picoamperes, you must clean the circuit with a flux solvent and then coat it with a drop of wax or epoxy resin.

In some cases, you might want to be able to adjust the timing of the switch. The circuit in **Figure 2** provides that option. It uses a tiny microcontroller in an SOT-23 package. **Listing 1**, which is available in the Web version of this Design Idea at www.edn.com/080710di1, contains the touch-activated timer switch. Items A, B, C, and D are the same as those in **Figure 1**. When the switch is off, the PIC10F200T microcontroller is in sleep mode and consumes practically no power. When you simultaneously touch contacts C and D, the level at Pin 1 of IC_1 goes high, and the microcontroller starts to tally the time that Pin 1 remains high. After 0.5 sec, the buzzer sounds a short beep. The buzzer then sounds two, three, and four fast beeps in 0.5-sec intervals. By immediately releasing contacts C and D after hearing any number of beeps, you can set the switch for 30 seconds, 30 minutes, four hours, and eight hours of operation, respectively. The choices of operating times are arbitrary; you can modify the code in **Listing 1** to whatever fits your application. Jump-

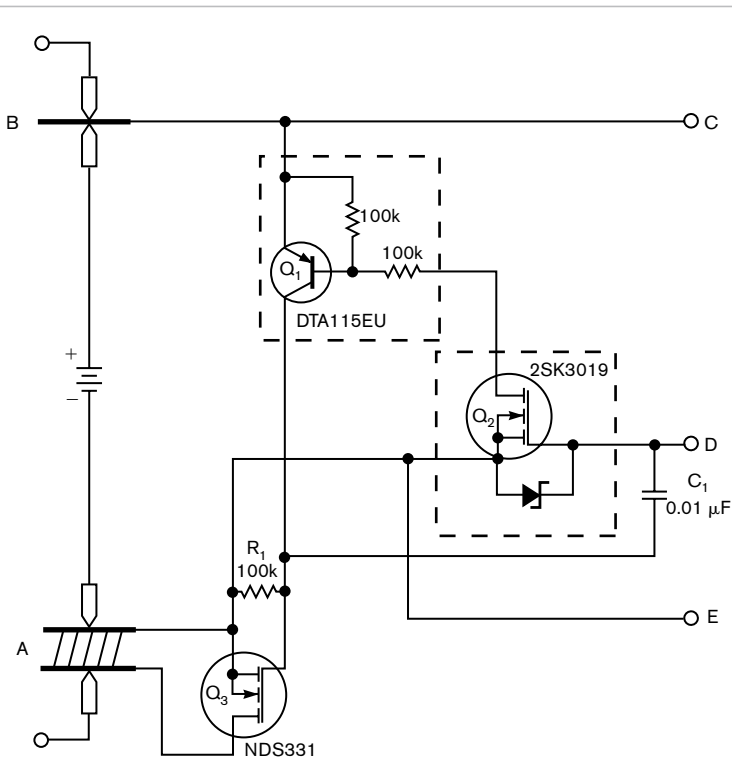

Figure 1 In parallel with the cells of a battery-powered device, this analog circuit disconnects the battery after a delay. Touching contacts C and D with a finger turns on the switch, connecting the cells to the load. The components fit inside the battery compartment.

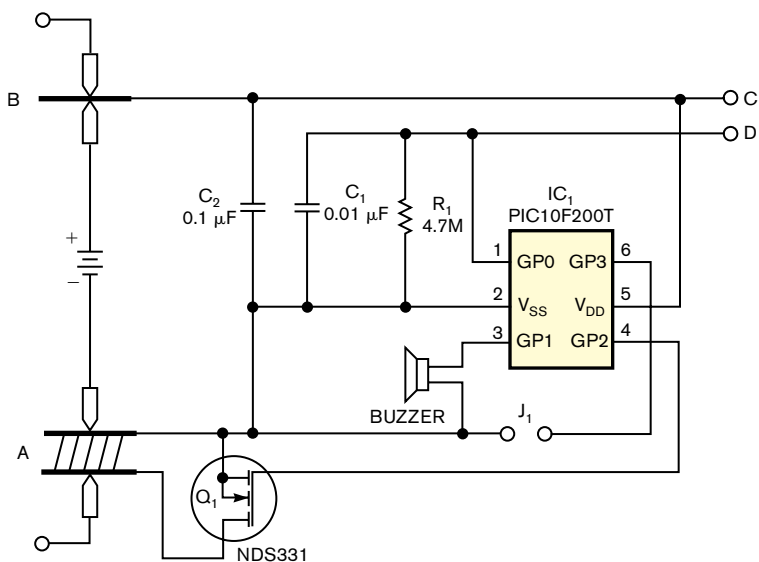

Figure 2 This digital implementation of the battery-disconnect switch uses a PIC10F200T microcontroller to control the disconnect switch.

er switch J_1 is optional. If you leave it open, touching C and D turns it off. Short-circuiting J_1 disables this option, and the switch will turn off only at the end of the programmed time. As is the case with the analog implementation, you mount all components except the buzzer at the edge of Item A. The buzzer is a small piezoelectric element with a resonant frequency of 4 kHz and can easily fit inside the battery compartment.

In some cases, you may not have access to the negative contact of the battery holder. The circuit in **Figure 3** addresses this situation. It is essentially the same as the circuit in **Figure 2**, except that you place Item A in series with the positive pole and attach B to the negative pole of the battery. A P-channel MOS transistor acts as a switch, and you modify the microcontroller's program to provide a low level to drive Q_1 . A comment in **Listing 1** indicates the proper line of code for the options in either **Figure 2** or **Figure 3**. **EDN**

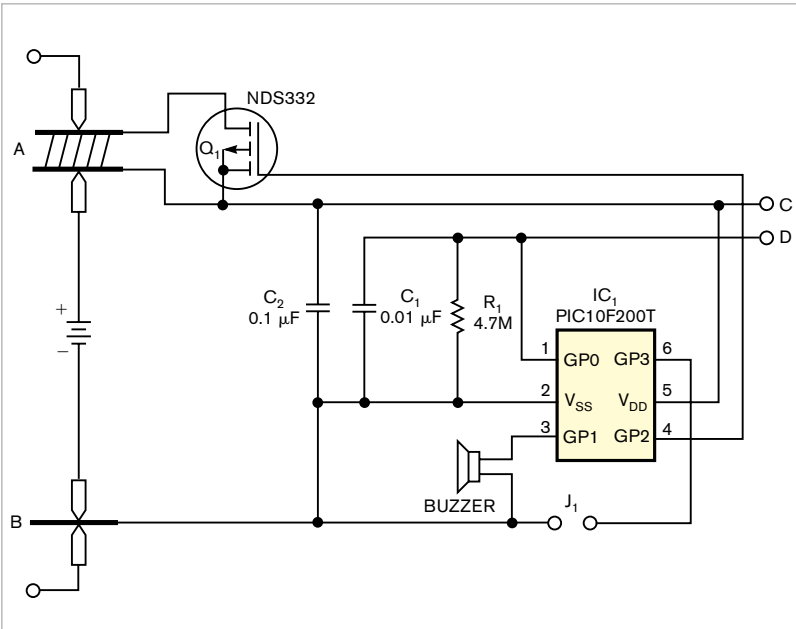

Figure 3 This circuit addresses the problem of a lack of access to the negative contact of the battery holder. It is essentially the same as the circuit in **Figure 2**, except that you place Item A in series with the positive pole and attach B to the negative pole of the battery.