

Driving high-power LEDs in series-parallel arrays

THE LIGHT FROM AN LED IS PROPORTIONAL TO THE CURRENT FLOWING THROUGH IT. THE CHALLENGE FOR THE DRIVE CIRCUITRY FOR APPLICATIONS USING MULTIPLE HIGH-BRIGHTNESS LEDs IS TO GET THE SAME CURRENT FLOWING THROUGH EACH LED AND TO BALANCE THE REQUIREMENTS OF SIZE, POWER EFFICIENCY, LEGAL/SAFETY STANDARDS, AND COST. EVERY BRANCH REQUIRES SOME FORM OF CURRENT REGULATION.

Scarcely a lighting application exists that designers have not considered converting to solid-state lighting, especially as LEDs by leaps and bounds improve both the quantity and the quality of their light output. However, only a few LEDs exist that can emit enough light from a single die to replace a 60W, 900-lm incandescent light bulb. Most applications require multiple LEDs with power ratings of 1 to 5W. When an application crosses the boundary from using just one LED to using two or more, the complexity of the approach increases more than twofold. The more LEDs you add, the more complex the approach becomes. A 900-lm light-bulb retrofit today may need 10 1W LEDs, but a 10,000-lm streetlight of the future may well need 100 LEDs. Binning, or sorting, for luminous flux and dominant wavelength/color temperature ensures that each LED illuminates equally but only as long as an equal current flows through each one.

Placing every LED in a single series chain is ideal from the perspective of equal drive currents (Figure 1a). Even a poorly designed LED driver with a wide tolerance of average current or with a wide or varying amount of ripple current still puts

the same current through each LED in a series configuration. The LED itself may change in brightness or color temperature, but this situation is preferable to variations in LED light output or color due to current variations.

The trouble comes as the number of LEDs in series grows. You can think of LED drivers as variable-voltage regulators that adjust their voltage output until the desired amount of current flows through their load: the LEDs. The dc voltage required to drive long strings of LEDs can quickly eclipse the limits of widely available electronics components, such as the diodes, transistors, and capacitors necessary for LED drivers. For example, Schottky diodes, which are popular in switching converters, are available only in voltages as high as 100V dc.

To further complicate matters, each LED has a typical forward voltage, along with a minimum and maximum forward voltage. The more LEDs you place in series, the wider the variation of the dc-drive voltage will be. Finally, the steady drop in forward voltage as LED-die temperature increases further widens the required range of output voltage. In short, the more LEDs an application needs, the more tempting it becomes to try a series-parallel array.

What if you could place the 100 LEDs for the 10,000-lm streetlight in an array of 10 parallel strings of 10 LEDs each? This approach would keep the maximum output voltage 10 times lower than having all 100 LEDs in series. Assuming a typical forward voltage of 3.5V for white LEDs, 350V dc decreases to 35V dc. This reduction is a definite improvement for safety, but at what price? The answer depends on how the LED-drive system balances the currents in each string. Having 10 LED drivers would guarantee independent control over each string, making current balance as good as the tolerances that each LED driver permits. However, adding 10 LED drivers, especially switching-regulator-based drivers with their attendant noise and relative expense, can increase system noise and BOM (bill-of-materials) costs. In an attempt to manage system cost and component count, many lighting-application designers consider driving a series-parallel array with N parallel strings using a single driver that provides higher current (Figure 1b).

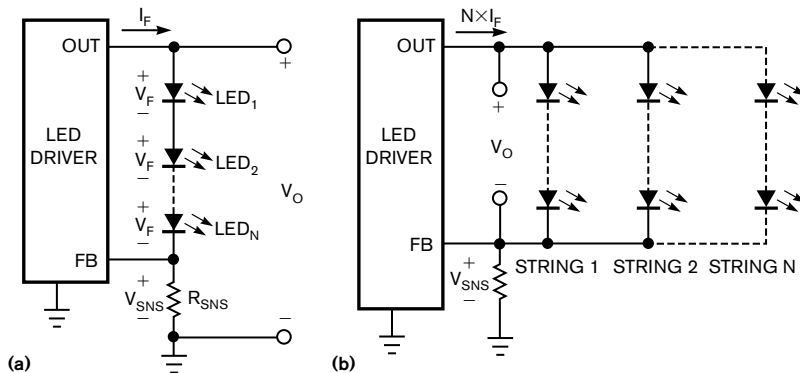

NOTES:
 I_F = FORWARD CURRENT.
 V_F = FORWARD VOLTAGE.

Figure 1 In a series array, the same current flows through all LEDs, equalizing the brightness and color of the string. However, the more LEDs in series, the greater the drive voltage, output voltage, and variation in range (a). One possible LED lighting architecture drives a series-parallel array with N parallel strings using a single driver to reduce the number of driver components (b).

Higher output current means higher output power, which in turn leads to more expense in an LED driver. The higher the output power, the more likely it is that you must use a switching regulator in place of a linear regulator because of the switcher's higher efficiency. The size of the components, especially inductors and transformers, increases with the current they carry. Even so, one high-power regulator is often more affordable than 10 smaller ones. The problem is that LEDs in parallel are notoriously poor at sharing current. Small mismatches in the dynamic resistance can result in large imbalances in current from string to string. The LED driver can increase the output voltage only until N times the forward current flows. Beyond that figure, such a driver circuit has no way of ensuring equal current in the LED strings.

Figure 2 shows a test of forward-voltage difference between four LEDs of the same part number but from different bins. The same benchtop dc-power supply drove each LED to ensure the same current, at an ambient temperature of 25°C. The testers took measurements

within 5 seconds of applying power to minimize the shift in forward voltage due to self-heating of the LED dice. A lighting-application designer could measure the same differing forward-voltage values from these four LEDs if they were in a single series chain. In a second test, the same four paralleled LEDs receive power from a 4A current source (Figure 3). Again, testers took measurements at 25°C ambient temperature and within 5 seconds of applying power. Once the LEDs are in parallel, the voltage across each one is equal; however, their varying dynamic resistances draw different currents. LED₂ has the lowest forward voltage at 1A and the lowest dynamic resistance of the group (Table 1). This result stands in contrast to LED₁, with the highest forward voltage and highest dynamic resistance. A seemingly small difference of 0.42V translates to more than three times the current flowing through LED₂.

Manufacturers bin LEDs for their luminous flux, color or color temperature, and forward voltage. Most LED manufacturers supply LEDs from only one bin on any given reel. For example, a typical forward-voltage bin might contain LEDs

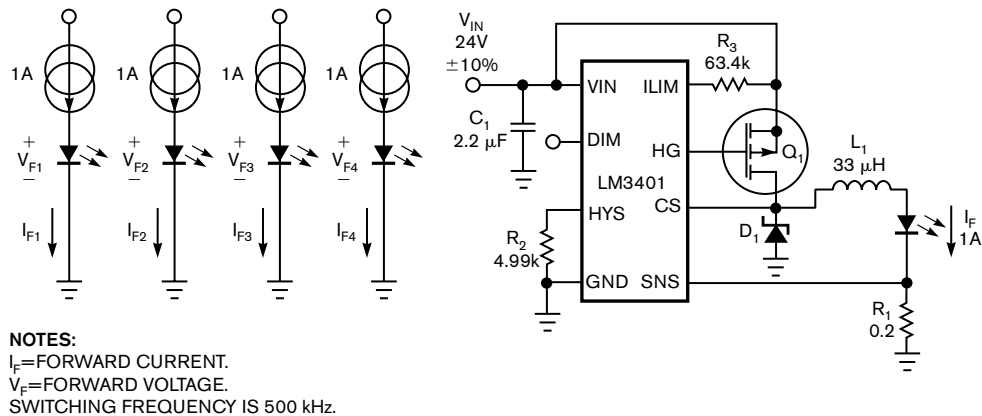

Figure 2 This test circuit measured the difference in forward voltage between four LEDs with the same part number but from different bins. The test circuit on the left used the same benchtop dc-power supply to power each LED at an ambient temperature of 25°C. The circuit on the right represents a practical 1A LED driver based on a buck regulator. Measuring forward voltage within 5 seconds of applying power minimized the shift in forward voltage due to self-heating.

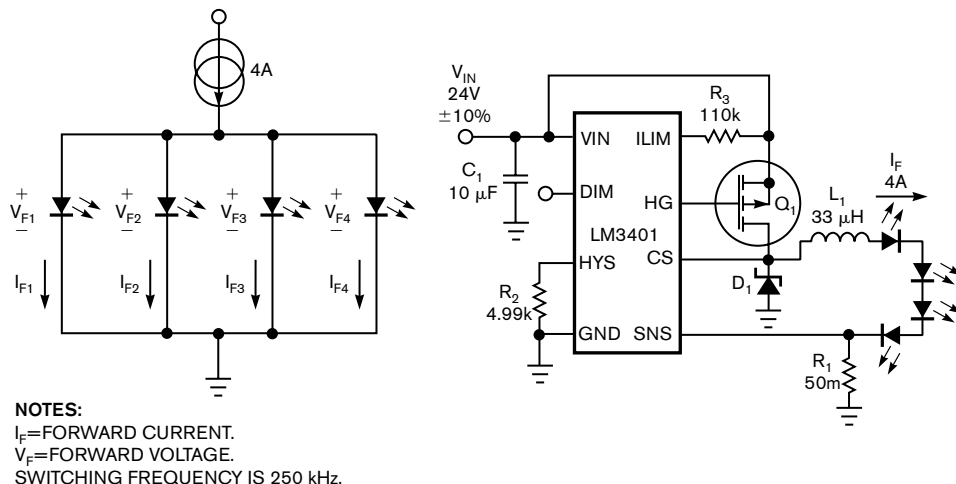

Figure 3 In this test, a 4A current source powered the same four LEDs in parallel.

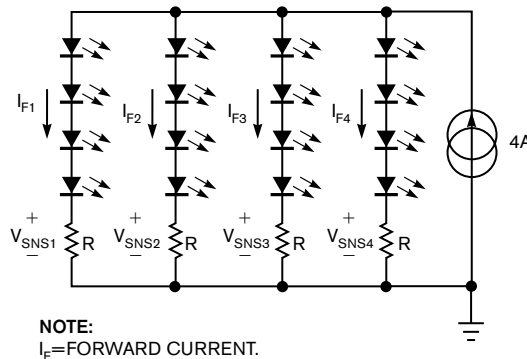

Figure 4 To gauge the current matching from string to string in a 4×4 series-parallel array, this test circuit uses 16 LEDs from the same forward-voltage bin, which a 4A benchtop power supply drives. Experimenters repeated the test with randomly selected LEDs from four forward-voltage bins.

TABLE 1 TEST RESULTS**Holding forward current constant for an individual 1A current source for each LED**

LED no.	Forward current (A)	Forward voltage (V)
1	1	3.83
2	1	3.41
3	1	3.59
4	1	3.52

Holding forward current constant for a single 4A current source powering all four LEDs in parallel

LED no.	Forward current (A)	Forward voltage (V)
1	0.45	3.56
2	1.53	3.56
3	0.91	3.56
4	1.1	3.56

with forward voltages of 3.27 to 3.51V at 25°C when the entire product ranges from 2.8 to 4.2V. The more tightly matched the forward voltages of the LEDs, the better the tolerance in current from string to string when using a series-parallel array. Unfortunately, buying every LED from the same bin is impractical and, in many cases, impossible. LED manufacturers would quickly find themselves drowning in the unpopular-LED bins if they guaranteed a specific bin to each customer. In practice, the manufacturers sell a distribution of devices across

TABLE 2 SERIES-PARALLEL-ARRAY TEST RESULTS**No forward-voltage binning**

String no.	Forward current at 25°C (A)	PCB temperature at thermal steady state (°C)	Forward current at thermal steady state (A)
1	1.48	114	1.38
2	0.68	95	0.76
3	1.24	113	1.26
4	0.66	80.8	0.58

Forward-voltage-binned LEDs

String no.	Forward current at 25°C (A)	PCB temperature at thermal steady state (°C)	Forward current at thermal steady state (A)
1	1.08	93.4	0.92
2	1.06	128	1.34
3	1.02	112	0.96
4	0.84	94	0.8

many bins, with the possible exception of very large orders.

Even if LEDs did share current equally, putting 100 LEDs in parallel would be just as impractical as having all 100 in series. A second experiment gauges the current matching from string to string in a more practical 4×4 series-parallel array. The experimenters arranged 16 LEDs from the same forward-voltage bin and powered them from a benchtop power supply with 4A.

High-precision-current, 5-mΩ sensing resistors in series with each string allowed individual current measurements and added a minimum amount of resistive ballasting. The experimenters then repeated the test with randomly selected LEDs from four forward-voltage bins. In each case, they took the 25°C measurements within 5 seconds of powering the array. They took thermal steady-state measurements with a handheld IR probe after leaving the array powered for one-half hour. **Figure 4** shows the circuit; **Table 2** details the results.

The results of **Table 2** show that matching the forward voltage of the LEDs in a series-parallel array does improve the current balance at 25°C from a worst-case string-to-string delta of 820 mA in the unmatched array to 240 mA in the matched array. However, even LEDs with forward voltages matched as tightly as the manufacturer can offer allow almost 25% of the 1A target dc current between strings. What's more, as soon as self-heating begins, the current sharing in the matched array becomes almost as poor as that in the unmatched array.

To combat potential mismatch in brightness or color lighting, designers can mix LEDs from different strings and employ blending optics; however, this approach does not address the positive-feedback loop that the drop in forward voltage creates as the LED-die temperature increases. Even when every LED comes from the same forward-voltage bin, one string will inevitably have the lowest forward voltage, and this string will draw more current than the rest. Higher current leads to higher power dissipation, and because this string is hotter than the others, its forward voltage will drop further. To further complicate matters, no binning exists for the rate at which forward voltage drops with die temperature, giving each LED a different slope. You can clearly see this effect by comparing the change in current balance in **Table 2** between 25°C and thermal steady state. In a large array with blending optics, the difference in light output from the hottest string might not be noticeable, yet the lifetime and lumen maintenance of the hottest LEDs decrease.

Manufacturers could bin LEDs for forward voltage to within 1 mV of one another, which would greatly improve their 25°C current sharing but would greatly increase their cost. Yet, even these extremely tightly binned LEDs, once they heated up, would not share current equally because of their differing forward-voltage/temperature slopes. Even if you take great care to ensure equal heat-sinking for each LED, the current mismatch in se-

ries-parallel arrays once they reach thermal steady state makes them impractical. You should include a current regulator in every parallel branch. A ballast resistor may suffice for some applications, and you can use a linear-regulator-current sink/source for others, but a switching regulator is the best choice for greatest power efficiency and flexibility. **EDN**

AUTHOR'S BIOGRAPHY

Chris Richardson is an applications engineer at National Semiconductor. He has a bachelor's degree in electrical engineering from Virginia Polytechnic Institute and State University (Blacksburg, VA).
