



HARDWARE AND SOFTWARE APPROACHES IMPLEMENT MULTIPLE RADIOS

BY RICK NELSON • EDITOR-IN-CHIEF

MINIATURIZATION AND EMERGING FLEXIBLE SOFTWARE ARCHITECTURES WILL ENABLE COMPACT, LOW-POWER WIRELESS DEVICES TO SUPPORT COMMUNICATIONS STANDARDS RANGING FROM BLUETOOTH TO WIMAX.

Today's on-the-go consumers may think they are carrying a single cell phone, but they're actually carrying seven or more radios that handle multiband-cellular operation, Wi-Fi networking, Bluetooth connectivity, assisted-GPS (global-positioning-system) functions, and more. In the future, they might have radios that implement ad hoc device-to-device communications, in which one device takes advantage of a nearby device that has better coverage (see sidebar "Ad hoc sharing could mean more radios"). To fit all the necessary radio functions into a portable wireless device, researchers throughout 2008 have been developing miniature multifunction modules and exploring flexible, low-power SDR (software-defined-radio) architectures.

The traditional way of implementing multiple radios in a single product is simply to design in multiple discrete radios—a transmit/receive function for each communications standard your product aims to support. That approach can take up a lot of real estate, a problem that Epcos addresses with its miniature front-end LTCC (low-temperature-cofired-ceramic)-radio modules. "We ship ... a fully tested RF system in a single package," says Patric Heide, PhD, the company's director of product development for modules. "In a mobile phone, you have the CMOS-based radio IC built in on one side, and, on the other side, you have the antenna. We provide a fully featured front-end module that goes between the two." To shrink multiple-radio implementations, Epcos offers multiradio modules, such as a Wi-Fi/WiMax (worldwide-interoperability-for-microwave-access) module (Figure 1). See Reference 1 for a discussion on how to test the modules.

Modules such as the Epcos LTCCs can accommodate semiconductor components such as GaAs (gallium-arsenide) power amplifiers, but the CMOS-radio chips that accompany the front-end

modules in the transmitter/receiver-signal chain embody many of the radio functions. You can use multiple CMOS chips to implement multiple radio standards. A more elegant approach involves using one flexible CMOS chip to implement multiple radio standards.

Justin R Rattner, vice president and chief technology officer of Intel, addressed that topic last June at the Design Automation Conference in Anaheim, CA (Reference 2). In a keynote speech, “EDA for digital, programmable multi-radios,” he noted that consumers want to “carry small yet live large”—that is, they expect compact designs to have multiple advanced features. To support this carry-small/live-large lifestyle, consumer devices must support “anywhere/anytime” collaboration, with the device able to communicate no matter what air interface—3G (third-generation) cellular, Wi-Fi, or WiMax, for example—is available.

Rattner acknowledged that we live in an analog world. “Analog is how we interact with the real world, but the technology favors digital,” he said. “So, we have to bridge the gap between the

AT A GLANCE

▣ Consumers want to “carry small yet live large”—that is, they expect compact designs to have multiple advanced features.

▣ “Digitally assisted analog” turns an analog problem into a digital one by relying on digital gates to improve analog performance.

▣ A cognitive radio can autonomously change its parameters based on interaction with the environment in which it operates, and it coexists with and uses the same spectrum.

▣ Industry watchers predict that radios’ ADCs will move ever closer to their antennas, yielding an intuitive, flexible full cognitive radio by approximately 2030.

analog world and the digital world.” Bridging this gap will be important for the carry-small/live-large lifestyle. He further acknowledged that the amount of analog circuitry is increasing: In 2006, more than 70% of SOCs (systems on chips) had analog elements. Unfortunately, however, traditional

analog development is not getting any easier in the face of transistor scaling. The reasons for this difficulty are increased mask costs; leakage and process-variation effects; output impedance; increased flicker noise; and reduced supply voltages, which decrease dynamic range.

His inclination is to employ “digitally assisted analog”—turning an analog problem into a digital one by relying on digital gates to improve analog performance. The technique exploits the computational nature of radio, which information theory embodies, to dramatically simplify radio architectures; to allow one radio to simultaneously act as many to, for example, facilitate seamless handoff between 3G and Wi-Fi networks; and to investigate the radio environment to see whether higher-performance networks are available.

In Rattner’s version of a digital-multiradio implementation, the traditional analog-receiver-signal chain, comprising a front-end module, a mixer, and a channel-select filter, for example, gives way to a simplified digital approach. Single chips can now implement a Wi-Fi or 3G radio. Tomorrow will bring integrated, programmable multiradio implementations to deal with any air interface they encounter. According to Rattner, Intel will probably need a year or so to produce commercial versions of such a digital radio, but the company has built a digital power amplifier in 65-nm CMOS and a fractional-N synthesizer in 90-nm CMOS.

An organization that’s far along in this effort is IMEC, which, at its Annual Research Review Meeting on Oct 14, 2008, in Brussels, Belgium, demonstrated an SDR platform. Liesbet Van der Perre, scientific director of

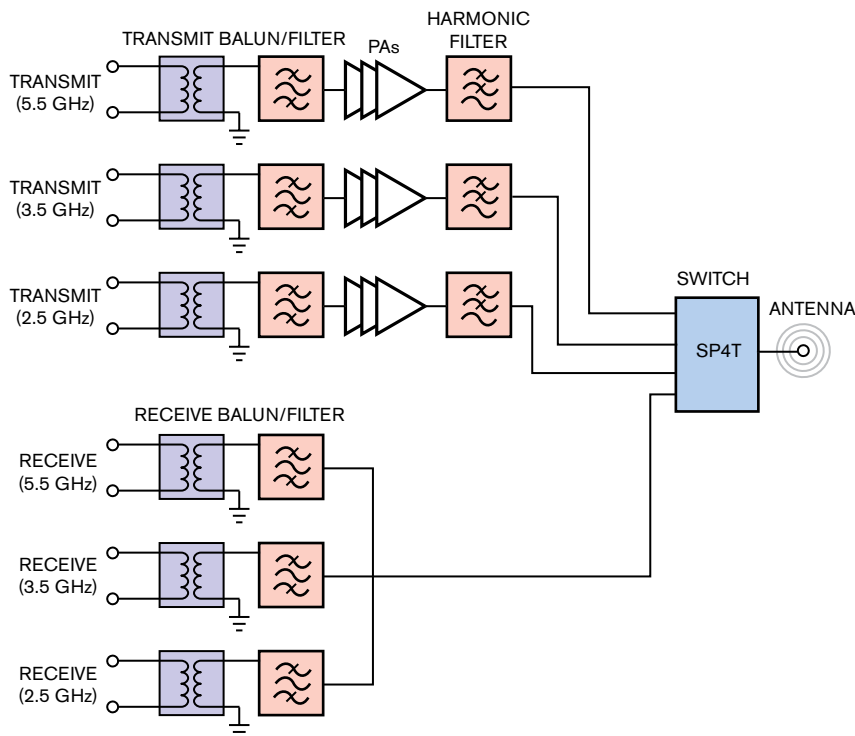

Figure 1 An Epcos triband front-end module, implementing 2.5- and 3.5-GHz WiMax as well as 2.5- and 5.5-GHz Wi-Fi, includes baluns, filters, power amplifiers, and an SP4T (single-pole/four-throw) switch on the RF-tested LTCC substrate.

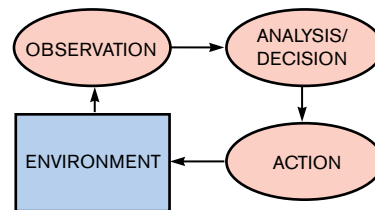
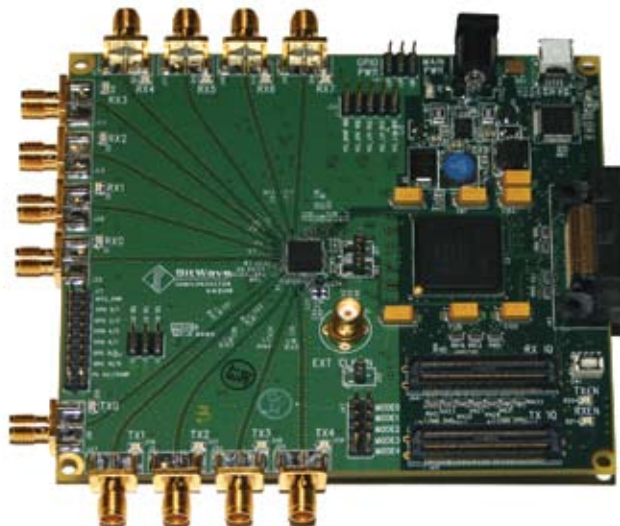

Figure 2 A cognitive radio can autonomously change its parameters based on interaction with the environment in which it operates.

wireless research at IMEC, says that the organization's SDR prototype integrates key components for next-generation flexible mobile terminals. The prototype incorporates an RF-transceiver and programmable-baseband platform, enabling the measurement of the performance and power consumption in real-life conditions and for different operating modes, she says.

Van der Perre reports that IMEC's flexible RF transceiver front end, SCALDIO (scalable radio chip), operates with all current and future cellular, WLAN (wireless-local-area-network), WPAN (wireless-personal-area-network), broadcast, and positioning standards in the 174-MHz to 6-GHz frequency range. IMEC's programmable-

Figure 3 An evaluation board provides access to the RF and digital sections of the BitWave RFIC so engineers can evaluate them in preparation for commercial release.



AD HOC SHARING COULD MEAN MORE RADIOS

If you have a mobile wireless consumer device, you probably know what radios it contains based on the functions you purchased. It might support multiband-cellular operation, for example, as well as Bluetooth, GPS (global-positioning-system), and Wi-Fi connectivity. In the future, however, you might carry a handset that includes stealth radios whose only function is to piggyback other neighboring devices to provide access to, for example, a clear GSM (global-system-for-mobile-communications) signal.

The US military has championed this technique, ad hoc networking, as a way to enhance communications in hostile environments, according to John Irza, technical-marketing manager at The MathWorks. Irza cites, for example, a first responder entering a damaged subway tunnel. The responder would quickly lose contact with the terrestrial-radio infrastructure but would maintain contact with the responders behind him, whose devices, in turn, can appropriately relay his signal.

Researchers at the NIST (National Institute of Standards and Technology) successfully demonstrated a prototype approach to maintaining two-way communications with first responders as they make their way in building fires and mine and tunnel collapses. These disasters and others in enclosed environments are often rife with radio dead spots and conditions that can severely weaken signals.

NIST researchers demonstrated an ad hoc system in August in conjunction with the 2008 Workshop on Precision Indoor Personnel Location and Tracking for Emergency Responders at Worcester Polytechnic Institute in Worcester, MA. At the workshop, they demonstrated a "breadcrumb-communication system" that advises first responders where to place relay devices that can extend the communications range. The NIST system makes decisions based on signal strength and eliminates the drawbacks of static approaches that require the

deployment of the relays—or "breadcrumbs"—at specific distance increments without regard to environmental factors.

The ad hoc technique may also find consumer applications. Speaking at the June IEEE MTT-S International Microwave Symposium in Atlanta, Mike Farmwald, director of Skymoon Ventures, suggested an approach in which communication moves from a cell phone to a tower model to a cell phone to a cell phone to a tower to an access-point model (Reference A). Cell phones could cooperate using a side channel, allowing one phone with a poor connection because of in-building loss, for example, to get help from a phone near a window 20 feet away. Two phones cooperating would experience a 3-dB improvement in SNR (signal-to-noise ratio), he said, and an ac-operated station without a user interface and near a window could yield a 15-dB improvement. Further, such a system could significantly reduce transmitting power.

Farmwald believes that the concept could be a win for all concerned: Consumer cell phones would have better connections, fewer dropped calls, and longer battery life, and carriers could double their bits-per-second-per-hertz performance with no changes to their infrastructures. Farmwald warned, however, that, even though the technology is not complex, the politics are. Wireless carriers, he noted, would need to drive a new generation of cell phones with side-channel capability—such as 1.9-GHz DECT (digital-enhanced-cordless telecommunication)—and carriers would need to adopt a universal standard for communication and authentication to address billing issues, for example.

REFERENCE

A Nelson, Rick, "Cell phones helping cell phones," *Test & Measurement World*, June 30, 2008, www.tmworld.com/blog/64000064/post/1160029116.html.

baseband platform—BEAR (baseband engine for adaptive radio)—supports standards such as 802.11n, 802.16e, and mobile TV, and it is forward-compatible with the upcoming 3GPP-LTE (Third Generation Partnership Project/Long-Term Evolution communication) standard.

The connectivity-centric SDR platform makes flexible and efficient use of network and spectrum resources across heterogeneous environments. SDR also serves as an enabling technology for spectrum-centric, opportunistic, cognitive-radio applications. A cognitive radio (**Figure 2**) can autonomously change its parameters based on interaction with the environment in which it operates, and it coexists with and uses the same spectrum resources as other wireless systems without introducing significant levels of interference. Full cognitive radio won't be available until 2025 or 2030, Van der Perre estimates, but evolutionary cognitive-radio features—that SDR implementations enable—will become available in the interim.

As for SDRs, companies dedicated to the concept include Vanu, which applies the technology to base stations to enable them to simultaneously operate GSM (global-system-for-mobile) communications, CDMA (code division/multiple access), and Motorola's IDEN (integrated digital enhanced network), for example. Another is BitWave Semiconductor, whose engineers have developed an SDR IC that can morph itself to work with at least 16 wireless-network interfaces, including GSM, WCDMA (wide CDMA), Wi-Fi, WiMax, and UMTS (universal-mobile-telecommunication-system) LTE. BitWave in early 2007 released the first prototypes of the device, the Softransceiver RFIC (radio-frequency integrated circuit). The IC is now nearing commercial release, with engineers testing the devices (**Figure 3**) and characterizing them in production volumes (**Reference 3**).

IMEC announced in October that Toshiba had licensed IMEC technology applicable to SDRs. And IMEC and Panasonic last month signed a joint-research contract concerning technologies in the semiconductor, networks, wireless, and biomedical fields. Under the terms of the contract, research will

take place at IMEC's Leuven, Belgium, facilities and research unit at Holst Centre in Eindhoven, the Netherlands. Part of the research will focus on dynamically reconfigurable SDRs.

John Irza, technical-marketing manager at The MathWorks, speaks from his company's vantage point as a supplier of baseband- and RF-simulation tools for chip and system vendors. He estimates that bandwidth users employ only 15

to 20% of available spectrum at once, leaving plenty of room for a cognitive radio to operate. Cognitive radio must, however, be agile enough to defer to the primary user of the spectrum when that user wants access to the spectrum that cognitive radio has appropriated. Irza notes that cognitive radio's challenges are both political and technical, requiring the approval of regulating bodies such as the Federal Communications

Commission in the United States. Thus far, the FCC has supported the cognitive-radio concept.

As for the future, Irza sees a trend toward integrated baseband/upband devices that support Bluetooth, Wi-Fi, GPS, and LTE communications standards as vendors overcome the challenges of moving digital-signal-processing functions closer to the antenna. IMEC's Van der Perre cites figures from

researcher ARCchart, which optimistically predicts that manufacturers will ship 157 million SDR-enabled handsets—or 11% of all handsets—in 2011. The researcher's pessimistic forecast is 74 million SDR-enabled handsets for the same year.

Van der Perre doesn't cite figures for SDRs or cognitive radios beyond 2011, but she does predict that radios' ADCs will move ever closer to their anten-

FOR MORE INFORMATION

ARCchart
www.arcchart.com

BitWave Semiconductor
www.bitwave-semiconductor.com

Epcos
www.epcos.com

IEEE Asian Solid-State Circuit Conference
www.a-sscc.org

IEEE MTT-S International Microwave Symposium
www.ims2008.org

IMEC
www.imec.be

Intel
www.intel.com

The MathWorks
www.mathworks.com

Motorola
www.motorola.com

National Institute of Standards and Technology
www.nist.gov

Panasonic
www.panasonic.com

Skymoon Ventures
www.skymoonventures.com

Toshiba
www.toshiba.com

Vanu
www.vanu.com

nas, yielding an intuitive, flexible full cognitive radio by approximately 2030. As a step toward that goal, IMEC presented at the IEEE Asian Solid-State Circuit Conference in November in Fukuoka, Japan, a 2.4-GHz sigma-delta ADC it fabricated in 90-nm CMOS. Research at IMEC continues on a scalable energy-efficient spectrum-sensing engine that could bring cognitive radio yet another step closer. **EDN**

REFERENCES

- 1 Nelson, Rick, "RF modules pose tough test challenges," *Test & Measurement World*, Oct 1, 2008, pg 29, www.tmworld.com/article/CA6599743.
- 2 Nelson, Rick, "Analog—that computes," *Test & Measurement World*, June 11, 2008, www.tmworld.com/article/CA6569252.
- 3 Rowe, Martin, "An RFIC for the world," *Test & Measurement World*, Sept 1, 2008, pg 36, www.tmworld.com/article/CA6589683.

⊕ Go to www.edn.com/081215df2 and click on Feedback Loop to post a comment on this article.

⊕ For more technical articles, go to www.edn.com/features.

You can reach
Editor-in-Chief
Rick Nelson
at 1-781-734-8418
and rnelson@reedbusiness.com.

