

designideas

READERS SOLVE DESIGN PROBLEMS

CMOS-NAND gates control sump pump

V Gopalakrishnan, Indira Gandhi Center for Atomic Research, Kalpakkam, India

With just a few NAND gates, you can control sump pumps and other pumps that keep your basement from flooding and maintain water levels in tanks. The circuit in **Figure 1** receives 12V signals from L_1 , the lower water level, and L_2 , the upper level, of an underground tank. You adjust the gap between these two levels to avoid short cycling of the pump. When the water level touches the maximum level of L_2 , the pump switches on to fill up the overhead tank. When the water level falls below the low level of L_1 , the pump switches off.

When the tank is empty, sensors L_1 and L_2 and Gate D are at low levels because the outputs of gates B and A are high. When the water level rises and shorts 12V through L_1 , the gate outputs remain the same. When the water level further rises and shorts 12V with L_2 , then the output of Gate A becomes low, which forces Gate D to a high level. That action, in turn, latches Gate B's output low. A low output on Gate B pulls down the SSR (solid-state relay), which turns on the sump pump (**Reference 1**). Simultaneously, the high output of Gate D turns on the gated oscillator and

DIs Inside

32 Use an LED to sense and emit light

34 Two instrumentation amps make accurate voltage-to-current source

36 Simple circuit indicates health of lithium-ion batteries

▶ To see all of EDN's Design Ideas, visit www.edn.com/designideas.

sounds the piezoelectric buzzer.

When the water level lowers below level L_2 , the pump remains on because of the latched B and D gates. If the water level falls below sensor level L_1 , the output of Gate B becomes high, which turns off the pump. This action

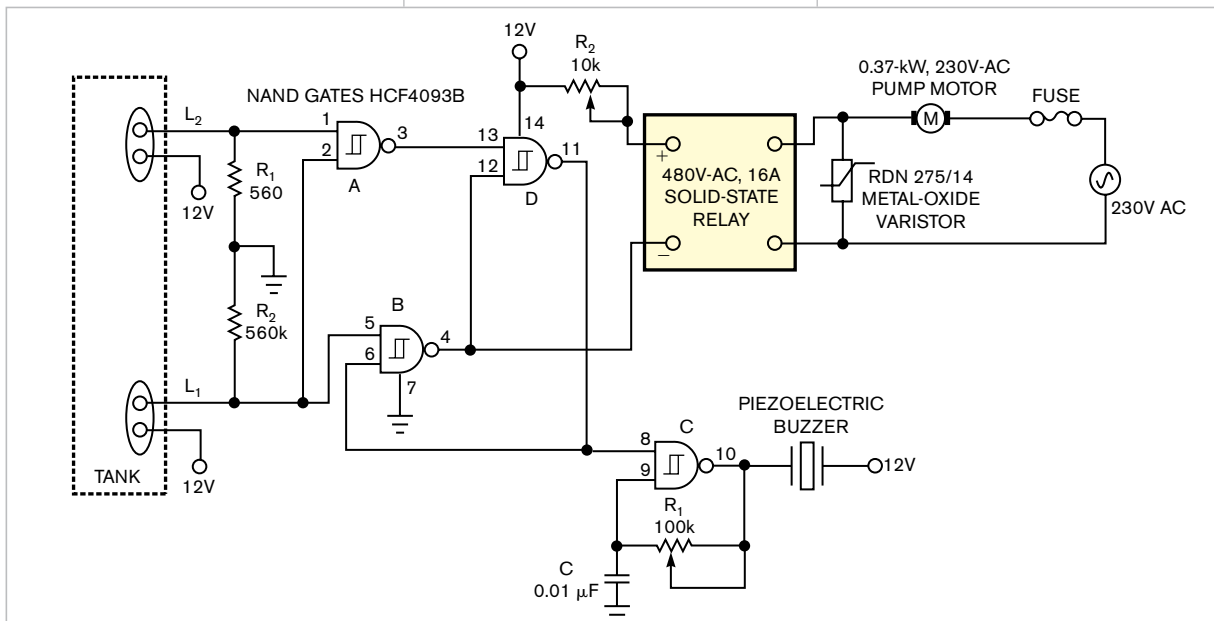

Figure 1 A sump-pump controller uses a quad-NAND gate to drive a solid-state relay.

makes the output of Gate D go to a low level, which stops the oscillator and thus the piezoelectric buzzer.

The circuit uses HCF4093B Schmitt-trigger-input NAND gates to square the slow signals. The input resistor, R_1 , has a value of 560 k Ω . Checking the circuit with a glass of filtered water shows an improved conductivity for ground water. Raising the value of the input resistor to a higher value is also not objectionable after you account for pickup and the voltage drop across the resistor due to the input leakage current.

The solid-state relay may have back-to-back connected SCRs (silicon-controlled rectifiers), random turn-on, and snubber circuitry to handle the motor load (Reference 2). Choose an SSR with a voltage rating that is double the working voltage and five to 10 times the current rating of the motor for withstanding dV/dt and the surge current. You should also use fast-blow fuses or semiconductor fuses with less than the I^2t rating of the SSR, where I is the current and t is the duration of current flow in seconds. Choose appropriate SSRs for different ratings of pump motors.

THE PARALLEL SENSOR WIRES AVOID THE CHANCE OF A MOISTURE INTERFACE BETWEEN THE WIRES WHEN THE WATER LEVEL FALLS BELOW THE SENSORS.

This circuit uses sheathed, single-strand, thick-gauge, edge-stripped copper wires as sensors. You can connect the sensor wires in two-way porcelain connectors, which you house in a box and place at the top of the tank. The parallel sensor wires avoid the chance of a moisture interface between the wires when the water level falls below the sensors. You can also use any other high-conductivity and noncorrosive wire material in some configurations. The power supply is floating.

With few modifications, the circuit in Figure 2 can perform a slightly different function. Assume that you have a

tank in which you want to maintain a level of water or any conductive liquid. Mount sensors L_1 and L_2 in the tank the same as those in Figure 1. Switching on the power supply causes the pump to begin to fill up the liquid in the tank. When the level reaches L_2 , the pump turns off. The pump remains off until the level falls to L_1 . When the level falls below L_1 , the pump again starts filling the tank until it reaches L_2 . The piezoelectric buzzer announces that the pump is running.

You can also control pumps with three-phase motors using a three-phase SSR or adding one appropriately rated single-phase SSR to this circuit. In this case, you can connect the inputs of the two SSRs in series. One SSR on each phase controls two of the phases, and you directly connect the third phase. **EDN**

REFERENCES

- 1 "Solid-state relay applications," Western Reserve Controls, www.wrcakron.com/applications/SSR_applications.pdf.
- 2 "Single-phase SSRs," ERI Solid State Relays, 2007, www.electronicrelaysindia.com/prod_001sjk_3.html.

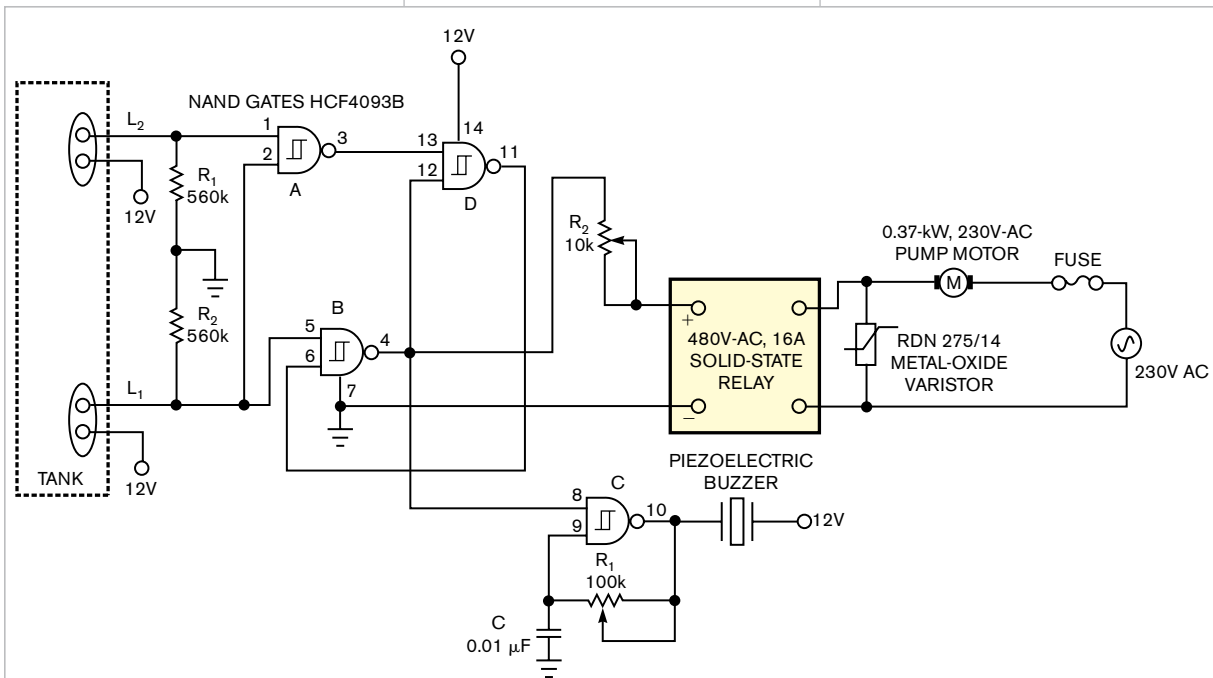

Figure 2 Connecting the potentiometer to NAND Gate B creates a water-level controller.

Use an LED to sense and emit light

Rafael Camarota, Altera Corp, San Jose, CA

LEDs in portable devices often show power status, battery status, or Bluetooth-connection activity. LEDs can be major factors in determining battery life because their intensity is directly proportional to power drain. Using a simple circuit, the MAX IIZ CPLD from Altera (www.altera.com) can measure the analog-light level of its environment and then drive an LED at a proportional analog intensity level. A single LED can both sense and emit light with the same LED and bias resistor. The circuit in **Figure 1** requires only 45 logic elements, and the

programmability of the CPLD makes it easy to quickly adjust the parameters of the circuit to the characteristics of any LED.

You can reduce the power consumption of a flashing LED by increasing the flash period, decreasing the flash pulse width, or decreasing intensity. Controlling the LED intensity based on ambient light reduces LED energy usage by more than 47% without affecting appearance. **Figure 1** shows a circuit that uses an Altera EMP240ZM100C7N CPLD, LED, resistor, and clock source to blink an LED with an intensity pro-

portional to ambient light. The circuit comprises a PWM (pulse-width modulator) for driving the LED, a light-intensity-measurement block, and a controlling state machine and timer.

The state machine includes one hot state comprising an 8-bit shift register initialized to the 00000001 binary. The carryout of Count 12, a 12-bit counter, generates an 8-Hz enable signal for state machine Shift 8. Thus, each of the eight states of the state machine is active for 125 msec. In State 0, the reset state, PWM Count 4 block and light-measurement block Count 8 are reset. State 1 is the light-intensity-measurement state, which enables a frequency counter, Count 8. Enabled for 125 msec, Count 8 counts the cy-

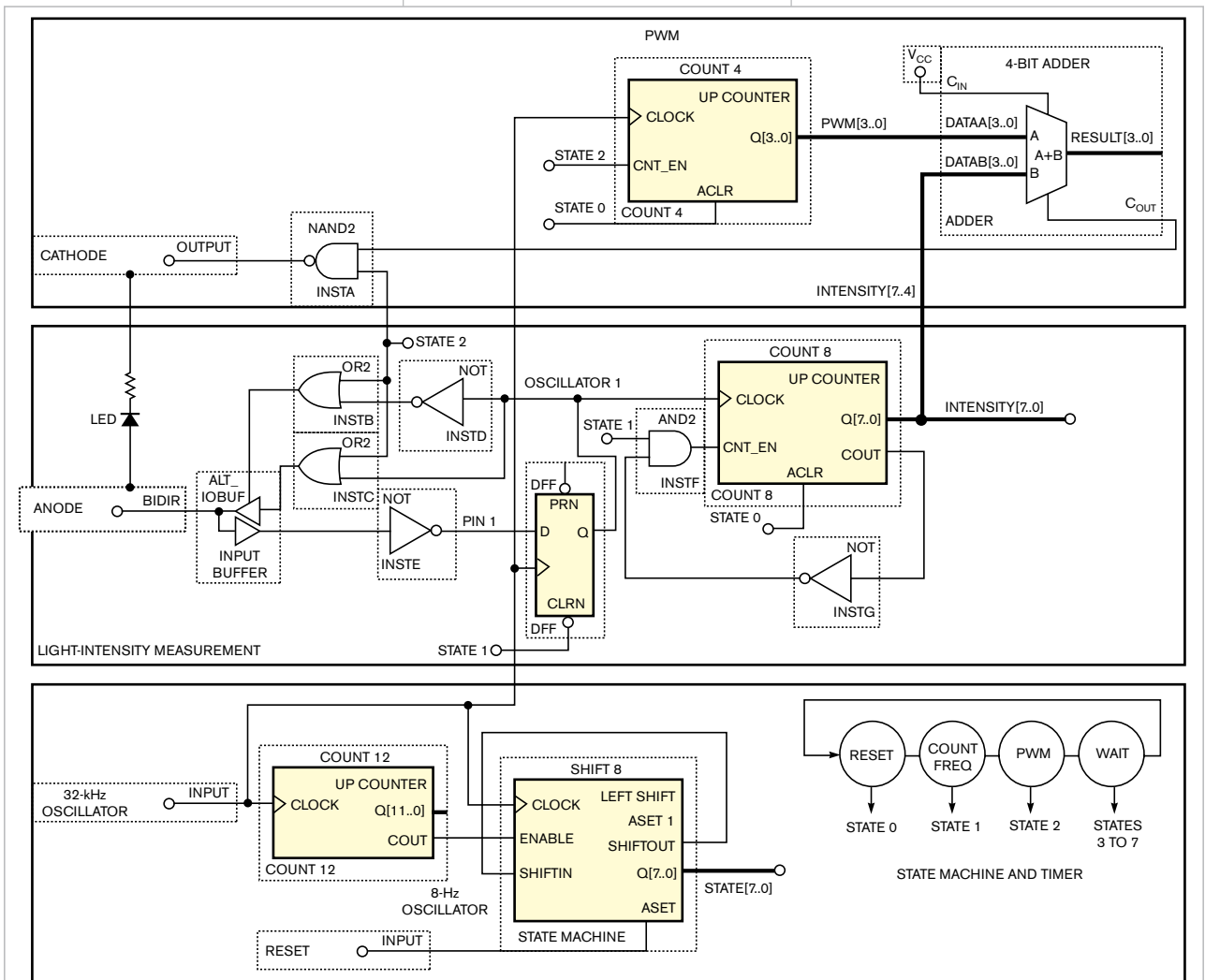

Figure 1 This simple MAX IIZ circuit uses an LED as an emitter and a sensor.

cles exiting the light sensor. The circuit senses the light by biasing the LED and current-limiting resistor such that the cathode lead of the LED is at logic one. The anode connects to a relaxation oscillator that starts with anode at logic zero. The LED pulls up the anode in proportion to the amount of light hitting the LED. The reverse-biased LED acts as a solar cell with output current proportional to light. Once the slow-rising anode signal reaches the threshold of the input buffer, the Pin 1 signal becomes a zero, and the D flip-flop, DFF, toggles to zero and drives the anode signal to zero, making Pin 1 a logic one and tristating the input buffer on the next clock cycle, allowing the anode signal to rise again.

The frequency of Oscillator 1 is proportional to light intensity, with typical frequency for bright light of approximately 2000 Hz. The Oscillator 1 signal drives the clock of Count 8. Count 8 resets in State 0 and then is enabled in State 1 for 125 msec. In bright light, Count 8 might count to 250 at the end of the measurement, and, in low light, it might count to only 16. The counter's C_{OUT} signal feeds back to the enable so that the count will saturate at a count of 255 and prevent high-intensity light from wrapping the counter back to zero and taking a false measurement.

State 2 is the LED's blinking state. This state blinks the LED for 125 msec at an intensity that a PWM controls. In State 2, the cathode and anode pins are bias to the emitter mode. The emitter mode forces the anode signal to V_{CC} . The cathode node connects to the PWM output. A logic zero on the cathode node lights the LED, and a logic one turns it off. The cathode signal is the inverted form of the PWM output.

In this example, the PWM is a 4-bit-resolution PWM, but you can use more or fewer bits. The PWM comprises binary counter Count 4 and a binary, 4-bit adder. The Count 4 counter is enabled in State 2, and the cycling output connects to the A input of the 4-bit adder. The B input of the adder connects to the four MSBs (most significant bits) of the light-sensor-frequency counter. The carryout of the adder is the PWM output. The carry-in of the adder is a constant logic one.

The following examples show how the PWM works:

- A logic zero from the intensity measurement results in a logic zero at carryout when Count 4 is zero through 14 and a logic one when Count 4 is 15. This 6.25% duty cycle is a very low-intensity level.
- A value of seven from the intensity measurement results in a logic zero

at carryout when Count 4 is zero to seven and a logic one when Count 4 is eight to 15. This 50% duty cycle is a medium-intensity level.

- A 15 from the intensity measurement results in no logic zero at carryout for any Count 4 value and a logic one when Count 4 is zero through 15. This 100% duty cycle is a full-intensity level.

The only function of states 3 to 7 is to wait for the next LED-flash cycle. You can add or remove states to change the flash rate. **EDN**

REFERENCES

- 1 Nicholls, Geoff, "Red LEDs function as light sensors," *EDN*, March 20, 2008, pg 90, www.edn.com/article/CA6541376.
- 2 Myers, Howard, "Stealth-mode LED controls itself," *EDN*, May 25, 2006, pg 98, www.edn.com/article/CA6335303.
- 3 Gadre, Dhananjay V, and Sheetal Vashist, "LED senses and displays ambient-light intensity," *EDN*, Nov 9, 2006, pg 125, www.edn.com/article/CA6387024.
- 4 Dietz, Paul, William Yerazunis, and Darren Leigh, "Very Low-Cost Sensing and Communication Using Bidirectional LEDs," Mitsubishi Research Laboratories, July 2003, www.merl.com/reports/docs/TR2003-35.pdf.

Two instrumentation amps make accurate voltage-to-current source

Frank Ciarlone, Analog Devices, Wilmington, MA

Many designs require precise voltage-controlled current sources, especially in the presence of variable loads. Common approaches, which use a few op amps and a handful of passive components, have inherent errors due to nonideal component characteristics, such as finite open-loop gain, common-mode rejection, bias current, and offset voltage. Designs using operational amplifiers may require precision resistors to set gain and additional capacitors for stability. In addition, some circuit designs

provide currents that are not directly proportional to the input voltage. The voltage-to-current converter in **Figure 1**, for example, relies on the fact that the collector current is approximately equal to the emitter current and provides current in only one direction.

With two instrumentation amplifiers and two transistors, you can build a 0.01%-accurate voltage-controlled current source (**Figure 2**). This current source features a $\pm 10V$ input-voltage swing that is directly proportional to the output current. It maintains high

accuracy, even while delivering as much as 90 mA of output current. The AD620 low-power, low-drift instrumentation amplifiers from Analog Devices (www.analog.com) provide circuit control and error correction but are not part of the output circuit. Thus, you can substitute higher-power transistors for Q_1 and Q_2 to achieve higher output currents. You can configure the instrumentation amplifiers for any gain of one to 10,000 to accommodate input signals lower than 1 mV. Simply connect a resistor across the inputs of both IC_1 and IC_2 to achieve the desired gain.

The first instrumentation amplifier, IC_1 , controls the base voltage of the push-pull output stage. The resistors

and diodes provide bias to Q_1 and Q_2 to eliminate crossover distortion. IC_2 provides error correction and accounts for deltas in the base-to-emitter voltage. The error voltage, which you measure differentially from the D_1/D_2 junction to the output voltage, feeds into the reference pin of IC_1 , summing it with the input voltage. The result is an output current that is directly proportional to the input voltage. This circuit achieves a 0.01% typical dc accuracy across a $\pm 10V$ input span and 1.5% typical ac accuracy at 1 kHz with an output voltage of $\pm 5V$ p-p.

The equations for calculating the output current are:

$$V_{OUT_{IC1}} = \left[(V_{IC1}^+ - V_{IC1}^-) A_{IC1} + V_{REF_{IC1}} \right]$$

$$V_{REF_{IC1}} = V_{OUT_{IC2}} =$$

$$(V_{IC2}^+ - V_{IC2}^-) A_{IC2} + V_{REF_{IC2}}$$

$$V_{OUT} = V_{OUT_{IC1}} = (V_{IC1}^+ - V_{IC1}^-) A_{IC1} + (V_{IC2}^+ - V_{IC2}^-) A_{IC2} + V_{REF_{IC2}}$$

where

$$V_{IC1}^+ = V_{IN}, V_{IC1}^- = 0; A_{IC1} = A_{IC2} = 1; V_{REF_{IC2}} = 0.$$

Therefore,

$$V_{OUT} = V_{IC1}^+ + (V_{IC2}^+ - V_{IC2}^-),$$

or

$$I_{OUT} = \frac{V_{IN}}{R_L}$$

This circuit provides a wide output range, as well as output current that is directly proportional to the input voltage and high linearity and precision (Figure 3). **EDN**

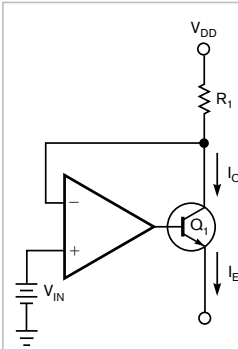

Figure 1 The voltage-to-current converter relies on the fact that the collector current is approximately equal to the emitter current and provides current in only one direction.

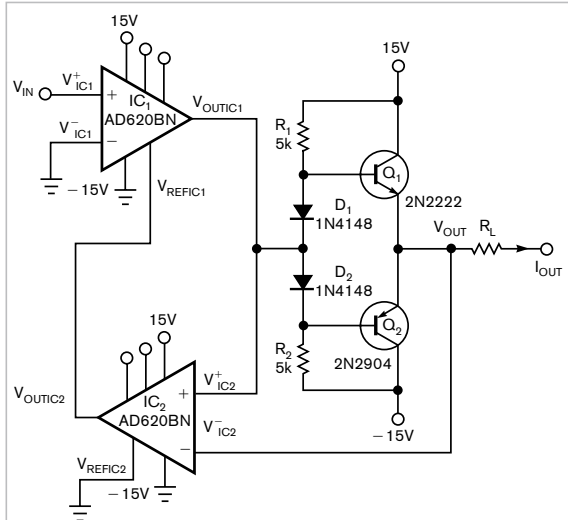

Figure 2 This handy voltage-to-current converter delivers high accuracy over a range of conditions.

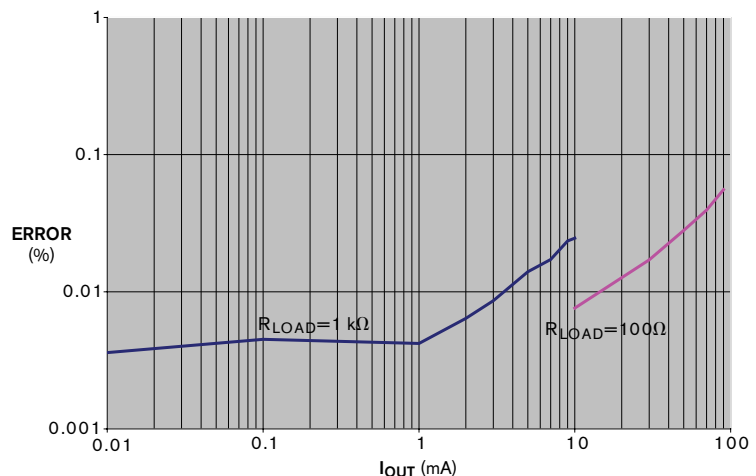



Figure 3 The circuit in Figure 2 provides a wide output range, output current that is directly proportional to the input voltage, and high linearity and precision.

Simple circuit indicates health of lithium-ion batteries

Fritz Weld, Friedberg, Germany

 Lithium-ion batteries are sensitive to bad treatment. Fire, explosions, and other hazardous conditions may occur when you charge the

cell below the margin that the manufacturer defines. Modern battery chargers can manage the hazardous conditions and deny operation when illegal

situations occur. This fact doesn't mean, however, that all cells are bad. In most cases, you can replace the discharged battery and increase your device's lifetime. **Figure 1** shows the circuit for testing battery packs.

When the supply voltage is lower than 2.6V, no current drives the base of the transistor. LED₁ lights up, and

LED₂ is off. When the voltage exceeds 2.6V, the transistor begins to short LED₁, turning it off and lighting LED₂. This condition indicates that the battery is below the allowed limit for recharging. The voltage margins highly depend on the type or color of the chosen LEDs. A standard red LED has a forward voltage of 1.7V; a green LED, about 2.1 or 2.2V. The circuit in this design uses red LEDs with forward voltages of approximately 1.6V at 2

mA. Other LEDs may require a simple redesign, mostly resulting in the requirement for a Schottky diode instead of the 1N4148 in this circuit. Even white or blue LEDs with 3V or more forward voltage make sense for certain applications.

Lower-value resistors increase the brightness of the LEDs but increase the supply current, as well. **Table 1** shows how this indicator provides three states

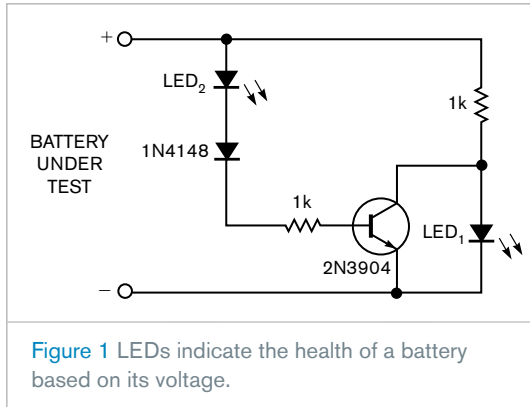

Figure 1 LEDs indicate the health of a battery based on its voltage.

of operation. Although this simple device draws little current, you cannot expect a long battery life if you use the

device as a permanent display, especially when it is in storage. Although a fully charged 32-Ahr cell will expire after about a year, an empty battery of the same size but slightly higher than the allowed margin for charging will expire after one or two days.

You can build an array of indicators in one test module. By connecting to the measuring/balancing port of the pack, you can easily inspect a whole pack with one view. Adding zener diodes in series to the LEDs also makes this circuit a simple indicator for higher voltage levels.**EDN**

TABLE 1 POSSIBLE LED CONDITIONS FOR BATTERY VOLTAGES

LED ₁	LED ₂	Indication	Condition
Off	Off	0 to 1.6V	Battery is empty, defective, or unusable.
On	Off	1.7 to 2.5V	Battery is below allowed limit for recharging.
Off	On	More than 2.6V	Battery is OK and can be charged.