



BY BONNIE BAKER



The non-negotiable single-supply operational amplifier

Fundamental analog devices that serve applications such as high-resolution delta-sigma or SAR (successive-approximation-register) converter systems are feeling the crunch from amplifiers that have difficulty with achieving good rail-to-rail input performance. The simple rail-to-rail operational amplifier must have a transistor design that spans the power supply with minimal distortion.

The trend toward designing single-supply op amps started in the 1970s with a single differential-input stage that spanned a portion of the common-mode input range. Later, designers added a second, or complementary, differential-input stage. The two stages shared, with some distortion, the rail-to-rail input operation across the complete amplifier's rail-to-rail common-mode range (Reference 1). Neither of

these approaches produced an amplifier adequate for the high-precision systems to span the amplifier's full common-mode input range.

Eventually, IC designers borrowed a technology from other devices to solve this problem. They began to use the all-too-common charge pump to push a single differential-input stage of the amplifier above the positive-power supply (Figure 1). Amplifier designers place the switching mechanism's frequency above the amplifier's bandwidth and keep the switching noise lower than the amplifier's thermal noise floor.

The single differential-input stage with a charge pump buys you a 20- to 30-dB increase in the amplifier's CMMR (common-mode-rejection ratio). This increase has a positive effect on amplifiers in buffer configurations. You can also expect almost a tenfold decrease in the amplifier's THD (total-harmonic-distortion) performance. So, if you use an amplifier that has a charge pump in its input stage to drive high-precision SAR or delta-sigma converters, your system's performance will improve.

For example, the THD of an ADC driven by an op amp in a buffer con-

figuration is the root-sum square of distortion contributions of the ADC and op amp. In this configuration, the system THD is:

$$THD_{SYSTEM} = 20 \log \sqrt{10^{(THD_{ADC}/10)} + 10^{(THD_{OPA}/10)}}$$

where $THD_{OPA} = 20 \log(THD_{OPA-\%} \times 100)$ and $THD_{OPA-\%}$ is the THD specification in the operational amplifier's data sheet in units of percentage.

Using these equations, if an operational amplifier with a complementary input stage has a THD specification of 0.004%, with an input voltage of 4V p-p, and the 16-bit SAR ADC has a THD specification of -99 dB, the system THD is -88 dB. Alternatively, if the op amp's input stage has a charge pump with a THD specification that is 0.0004%, the system THD becomes -98 dB.

Single-supply amplifiers continue to keep pace with high-resolution converters because engineers implement innovative amplifier-circuit topologies, such as an input stage with a charge pump. The charge pump is a good stopgap; however, engineers continue to demand lower system power supplies and insist on better signal integrity. **EDN**

REFERENCES

- 1 Baker, Bonnie, "Where did all the racket come from?" *EDN*, April 23, 2009, pg 18, www.edn.com/article/CA6651590.
- 2 "OPA365, OPA2365 2.2V, 50MHz, Low-Noise, Single-Supply Rail-to-Rail Operational Amplifiers," Texas Instruments, June 2006, www.ti.com/opa365-ca.
- 3 "OPA333, OPA2333 1.8V, micro-Power CMOS Operational Amplifiers, Zero-Drift Series," Texas Instruments, March 2006, www.ti.com/opa333-ca.

Bonnie Baker is a senior applications engineer at Texas Instruments and author of *A Baker's Dozen: Real Analog Solutions for Digital Designers*. You can reach her at bonnie@ti.com.

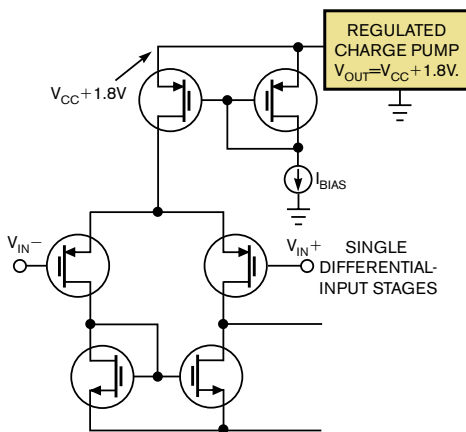

Figure 1 In this configuration, a charge pump pushes a single differential-input stage of the amplifier above the positive-power supply.