

# designideas

READERS SOLVE DESIGN PROBLEMS

## Quasiresonant flyback converter easily charges energy-storage capacitors

Todor Arsenov, Toronto, ON, Canada

Designers often use chargers with flyback topologies to quickly charge energy-storage capacitors (references 1 and 2). In a flyback topology, the energy transfer takes place only when the charger's power MOSFET is off, which effectively isolates the power switch from the load, comprising high-energy storage-capacitor banks. Thus, the voltage levels on the circuit transformer's secondary can vary from zero to a predetermined value and corresponding energy level without any significant stress on the components on the primary side of the transformer.

The classical flyback capacitor charger operates in CCM (continuous-conduction mode). Flat-topped, short-duration current pulses on the transformer's secondary charge the storage capacitors (Reference 3). Unfortunately, this charging strategy requires complex control circuitry to limit both the secondary current and the capacitor voltage. Most circuits use a specialized PWM (pulse-width-modulation)-controller IC, which increases the overall cost of the charger. Another disadvantage of the CCM is the small portion of energy that accumulates during the on-time of MOSFET conduction:

### DIs Inside

42 First-event detector has automatic-reset function

43 Signal-powered linear optocoupler provides isolated control signal

45 Dark-activated switch needs only three components

▶ To see all of EDN's Design Ideas, visit [www.edn.com/designideas](http://www.edn.com/designideas).

$$\Delta W = \frac{1}{2} \times (L_P \times I_{P_{PK}}^2 - L_P \times I_{P_{OFFSET}}^2),$$

where  $I_{P_{OFFSET}}$  signifies the initial non-zero primary current at the beginning

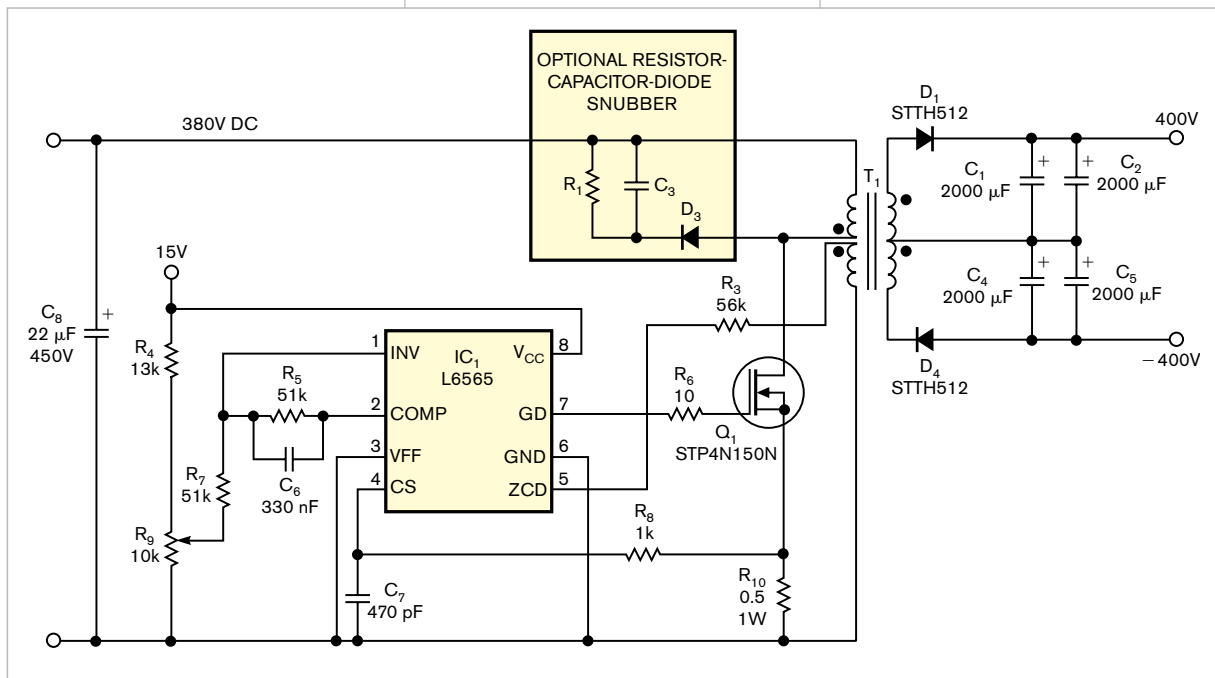

Figure 1 A flyback capacitor charger uses BCM operation.

of the on-time interval.

Only this limited portion of energy transfers from the primary to the secondary sides and enters the storage capacitor. Therefore, you can considerably increase the amount of energy transferable to the capacitive load if the converter can operate in BCM (boundary-conduction mode). The secondary current becomes zero, and the power MOSFET turns on, and the primary current builds from zero. Thus, a bigger portion of energy accumulates during every consecutive on-time interval:

$$\Delta W = \frac{1}{2} \times L_p \times I_{p_{pk}}^2.$$

With all other conditions equal, BCM operation ensures faster accumulation of a predetermined amount of energy because of the bigger stored portions of energy during the on-time intervals. Many converter circuits that operate using BCM incorporate PWM controllers that implement BCM operation for capacitor charging. These circuits often use Maxim (www.maxim-ic.com) MAX8622 or Linear Technology (www.linear.com) LT3468 ICs. These ICs are specialized devices to accommodate BCM operation.

You can, however, implement flyback BCM operation without these specialized parts. Manufacturers implement BCM in the variable-frequency versions of flyback converters, which are quasiresonant, ZVS (zero-voltage-switching) converters that commonly find use in TV SMPS (switched-mode-power supplies). For example, you can use the STMicroelectronics (www.st.com) quasiresonant-SMPS-controller L6565 to build a flyback capacitor charger working in BCM (**Reference 4**). Doing so eliminates the need for using a specialized chip for capacitor chargers.

**Figure 1** shows the power stage of a charger using the ST L6565. It achieves the BCM using a second primary winding on  $T_1$  that feeds the transformer-sensing input at the ZCD pin of the L6565. The voltage of this winding is a scaled-down replica of the drain-to-source voltage of power MOSFET

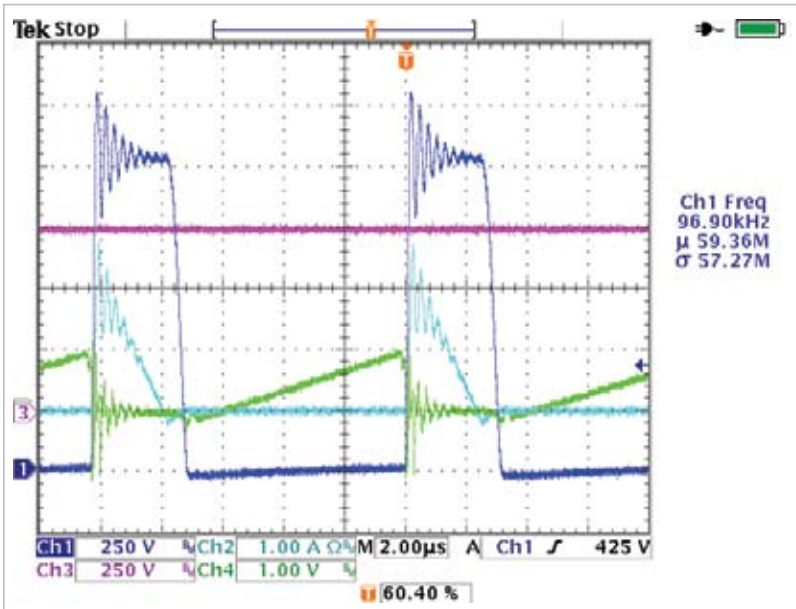

**Figure 2** When the secondary current reaches 0A, the MOSFET turns on, and the primary current increases from 0A.

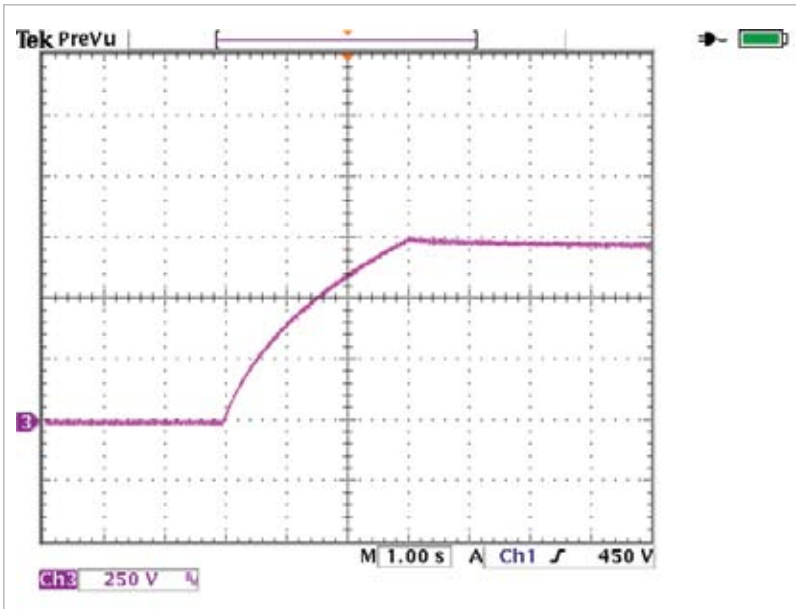

**Figure 3** The output-capacitor voltage reaches its full level in about 3 seconds.

$Q_1$ . When the circuit interrupts the secondary current—indicating full demagnetization of  $T_1$ —it detects the minimum of the first valley of ringing, and the L6565 turns on the MOSFET. This action eliminates the idling and zero-phase-time intervals, thus establishing BCM. The elimination of the zero-phase-time intervals greatly re-

duces the charging time of the storage capacitors.

At the beginning of the charging sequence, the output voltage is low because of the large capacitance values. The secondary current decreases slowly. The reflected voltage on the primary side is too low to trigger the ZCD pin of the L6565. Thus, the L6565's

initial starting timer sets the switching frequency to 2.5 kHz at the start of charging. The output voltage across the storage capacitors increases to a point at which the switching frequency becomes variable because of the demagnetization of the transformer core. **Figure 2** shows that, as soon as the secondary current (Channel 2) becomes 0A, the power MOSFET turns on, and the drain-to-source voltage decreases (Channel 1). At that time, the primary current again increases (Channel 4). At the output voltage close to full charge, the switching frequency is approximately 100 kHz. **Figure 3** shows the total voltage of 750V across  $C_1$ ,  $C_2$ ,  $C_4$ , and  $C_5$  within a 3-second charging time.

The waveforms in **figures 2** and

**3** are evaluation measurements of a prototype capacitive charger using the L6565 and power MOSFET STP4N150. A low-power PFC (power-factor-correction) stage, using transition-mode-PFC controller L6562, delivers the input-bus voltage of 380V dc. This configuration ensures not only the dc-voltage bus for the power stage of the charger, but also a high power factor during the charging phase. **EDN**

## REFERENCES

- 1 Lan, Rayleigh, and Hunter Chen, "Flyback Charge Xenon Flash Capacitors," *Power Electronics Technology*, March 2007, <http://powerelectronics.com/mag/703PET24.pdf>.
- 2 Creel, Kirby, "Expedite Transformer

Calculations for Flybacks," *Power Electronics Technology*, January 2008, [http://powerelectronics.com/passive\\_components\\_packaging\\_interconnects/magnetics/transformer-calculations-defibrillator-capacitors-0108](http://powerelectronics.com/passive_components_packaging_interconnects/magnetics/transformer-calculations-defibrillator-capacitors-0108).

- 3 Sokal, NO, and R Redl, "Control algorithms and circuit designs for optimally flyback-charging of an energy storage capacitor (e.g., for flash lamp or defibrillator)," *IEEE Transactions on Power Electronics*, Volume 12, Issue 5, September 1997, [http://ieeexplore.ieee.org/xpl/freeabs\\_all.jsp?tp=&number=623007&isnumber=13547](http://ieeexplore.ieee.org/xpl/freeabs_all.jsp?tp=&number=623007&isnumber=13547).
- 4 "L6565 Quasi-Resonant SMPS Controller," STMicroelectronics, <http://eu.st.com/stonline/products/literature/ds/7587/l6565.pdf>.

## First-event detector has automatic-reset function

Vasil Borodai, Zaporozhje, Ukraine

The circuit in **Figure 1** lets you indicate which game player presses a button first. Each button has a corresponding LED that indicates the pressing of the button. All other LEDs remain locked out until someone presses a reset button. When a player presses a pushbutton, the corresponding optoisolator turns on, which illuminates the appropriate indicator

LED. The LED remains on after the player releases the pushbutton. The voltage at Point A pulls down to nearly 3.7V, which you determine by adding the forward voltage of the optoisolator's internal LED, the phototransistor's voltage, and the LED's voltage:  $1.3 + 0.6 + 1.8V = 3.7V$ . The green LED then turns off.

Beginning at time  $T_1$  (**Figure 2**),

no other player can change the situation by pressing a pushbutton because switching on any other optoisolator requires a voltage exceeding 3.9V. Resistor  $R_1$  depends on  $V_{PS}$  such that  $R_1 = (V_{PS} - V_{D1}) / I_{OPTOLED}$ , where  $V_{PS}$  is the power-supply voltage,  $V_{D1}$  is the voltage of diode  $D_1$ , and  $I_{OPTOLED}$  is the current of the optoisolator LED. Thus, for a 9V power supply,  $R_1$  has a value of 1.5 k $\Omega$ . When a player presses the reset button, the player LEDs turn off, and the green LED illuminates. The voltage at Point A returns to 9.2V (time  $T_2$  in **Figure 2**).

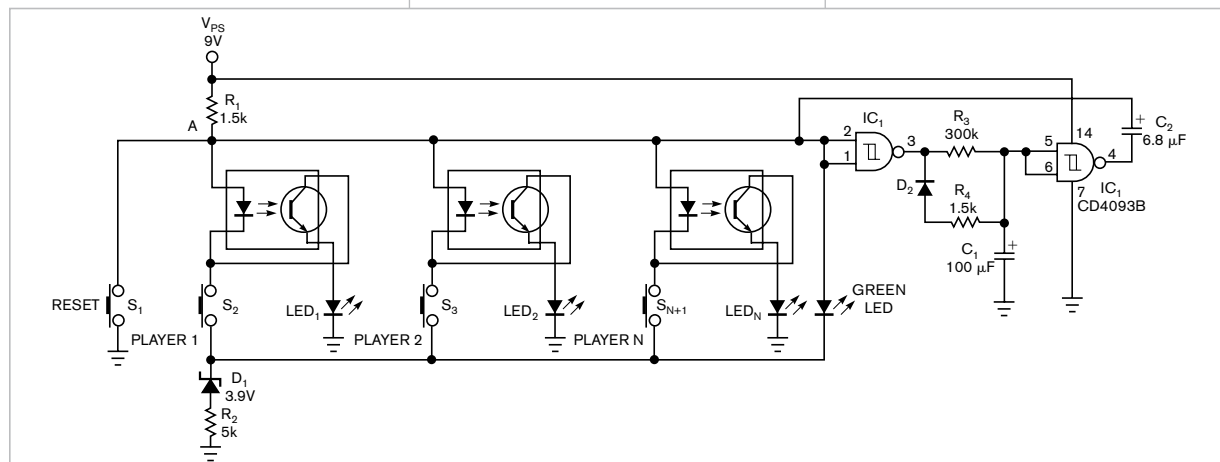

**Figure 1** This circuit lets you indicate which game player presses a button first.

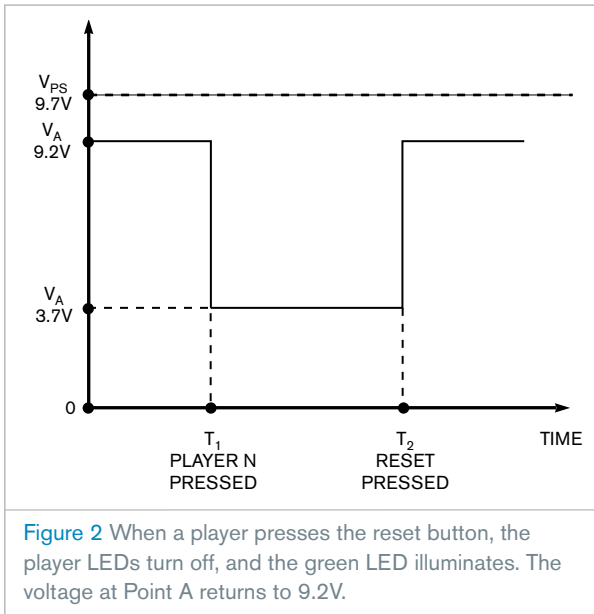

**Figure 2** When a player presses the reset button, the player LEDs turn off, and the green LED illuminates. The voltage at Point A returns to 9.2V.

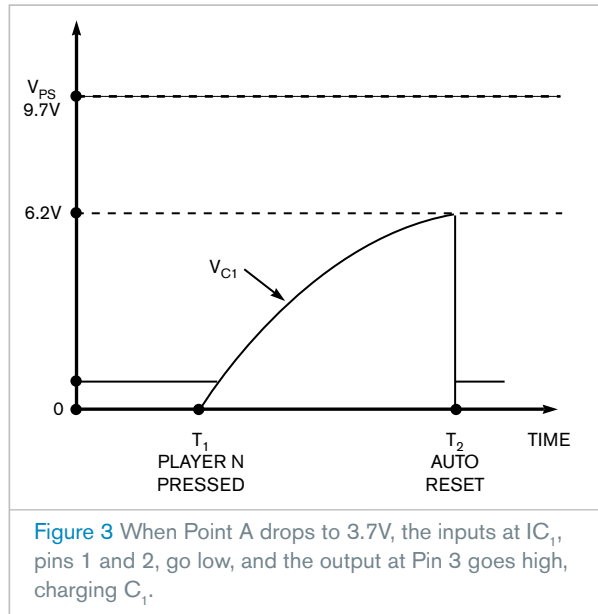

**Figure 3** When Point A drops to 3.7V, the inputs at IC<sub>1</sub>, pins 1 and 2, go low, and the output at Pin 3 goes high, charging C<sub>1</sub>.

You can also add an auto-reset feature to the circuit. When Point A drops to 3.7V (time T<sub>1</sub> in **Figure 3**), the inputs at IC<sub>1</sub>, pins 1 and 2, go low, and the output at Pin 3 goes high, charging C<sub>1</sub>. After about 30 seconds (time T<sub>2</sub> in **Fig-**

**ure 3**), C<sub>1</sub> has enough voltage to force IC<sub>1</sub>'s Pin 4 low. R<sub>3</sub> and C<sub>1</sub> determine the charging time. A pulse of current flows through C<sub>2</sub>, which forces the voltage at Point A to nearly 2V. That action momentarily interrupts the cur-

rent in any optoisolator LED. As a result, the circuit automatically resets, and the green LED lights. IC<sub>1</sub>'s Pin 3 goes low, which discharges C<sub>2</sub> through R<sub>2</sub>, resetting the circuit to its original state.**EDN**

## Signal-powered linear optocoupler provides isolated control signal

Mitja Rihtarsic, Škofja Loka, Slovenia

The circuit in **Figure 1** provides an isolated control voltage, such as 0 to 10V. In the low part of the range, 0V to approximately 2V, the controlled device is off. Therefore, the upper part of the range must be as linear as possible. You can meet this requirement using a linear optocoupler, such as Vishay's ([www.vishay.com](http://www.vishay.com)) IL300 or Avago Technologies' ([www.avagotech.com](http://www.avagotech.com)) HCNR200 or HCNR201.

These optocouplers each comprise an LED and a photodiode on the transmitting side and an identical photodiode on the receiving side. Because of this construction, the emitted light from the LED should cause the same current to flow in both photodiodes. The current through the photodiode on the receiving side, feedforward cur-

rent I<sub>FF</sub>, is the output current, and you must set this current in proportion to the transmitted signal voltage, V<sub>1</sub>. This current equals the feedback current, I<sub>FB</sub>, through the transmitter-side

photodiode. A feedback loop around the emitting side of the optocoupler keeps the feedback current in proportion to the transmitted signal. When the feedforward current and the feedback current are equal, the output current is proportional to the transmitted signal.

The hidden cost, however, is a power supply. You need some power on both

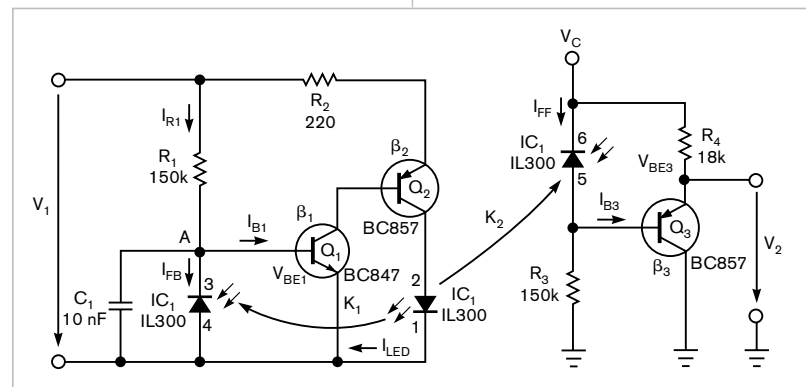

**Figure 1** Optocoupler IC<sub>1</sub> isolates the control circuit's input and output.

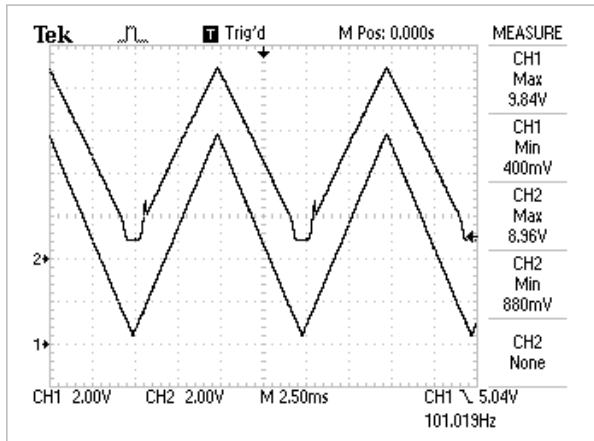

**Figure 2** The output voltage (upper trace) turns off when the input voltage (lower trace) gets too low.

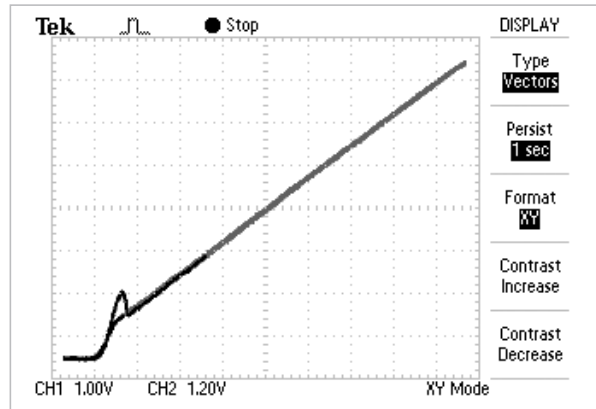

**Figure 3** An XY plot of the circuit's input and output voltages shows linearity once the input voltage is high enough to power the circuit.

sides of the signal path. The circuit in this Design Idea uses power from signal voltage  $V_1$  to supply a feedback loop in the transmitting side similar to the way some circuits in a 4- to 20-mA loop get power from the loop current. Both photodiodes operate in reverse-biased, photoconductive mode. The currents through them are proportional to incident-light flux, which feedback gain  $K_1$  and forward gain  $K_2$  describe.

$$K_1 = \frac{I_{FB}}{I_{LED}}, \quad (1)$$

where  $I_{LED}$  is the LED's current, and

$$K_2 = \frac{I_{FF}}{I_{LED}}. \quad (2)$$

A description of the circuit begins with a sum of the dc currents at Node A.

$$\frac{V_1 - V_{BE1}}{R_1} = I_{FB} + I_{B1}. \quad (3)$$

The gains of both transistors amplify current  $I_{B1}$  into the base of  $Q_1$ . The amplified current then flows through the LED.

$$I_{LED} = \beta_1 \beta_2 \times I_{B1}. \quad (4)$$

**Equations 1** through **4** yield the output feedforward current:

$$I_{FF} = (V_1 - V_{BE1}) \times \frac{1}{R_1} \times \frac{K_2 \beta_1 \beta_2}{K_1 \beta_1 \beta_2 + 1}. \quad (5)$$

When the product of feedback gain  $K_1$  and transistor gains  $\beta_1$  and  $\beta_2$  is much greater than one, you can cancel out the transistors' gains, yielding a characteristic that is linear:

$$I_{FF} = (V_1 - V_{BE1}) \times \frac{1}{R_1} \times \frac{K_2}{K_1}; K_2 \beta_1 \beta_2 \gg 1. \quad (6)$$

The ratio of feedback gain  $K_1$  and forward gain  $K_2$  is transfer gain  $K_3$ . Because  $K_1$  and  $K_2$  are similar,  $K_3$  is approximately one. In reality,  $K_3$  may deviate, but it changes less than  $K_1$  or  $K_2$  alone:

$$K_3 = \frac{K_2}{K_1}. \quad (7)$$

**Equation 6** subtracts the base-to-emitter voltage from the input voltage. Although the base-to-emitter voltage is not constant, it is desirable to remove it. You accomplish this task using the emitter follower in the receiving circuit. The output voltage,  $V_2$ , is a sum of voltage across  $R_3$  and the base-to-emitter voltage of  $Q_3$ .

$$V_2 = (I_{FF} + I_{B3}) \times R_3 + V_{BE3}. \quad (8)$$

You can use a different **equation** to yield the feedforward output current:

$$I_{FF} = \left( (V_1 - V_{BE1}) \times \frac{1}{R_1} - I_{B1} \right) \times K_3. \quad (9)$$

You can rearrange **equations 8** and **9** as:

$$V_2 = V_1 \frac{R_3}{R_1} K_3 + \left( V_{BE3} - V_{BE1} \frac{R_3}{R_1} K_3 \right) + R_3 (I_{B3} - I_{B1} K_3). \quad (10)$$

In the first term in **Equation 10**, the ratio of resistors  $R_3$  and  $R_1$  is approximately 1-to-1. You must be careful with the transfer gain,  $K_3$ , which is the reason that  $K_3$  remains in **Equation 11**.

$$V_2 \approx K_3 \times V_1. \quad (11)$$

When  $K_3$  is one, voltages  $V_{BE1}$  and  $V_{BE3}$  cancel each other to some degree. Therefore, **Equation 11** omits the second term in **Equation 10**. Base current  $I_{B3}$  depends on resistor  $R_4$  and the output load. When you can set both base currents to be equal, the last term would cancel out, too. The values of resistor  $R_2$  and capacitor  $C_1$  must be small enough so that transistors  $Q_1$  and  $Q_2$  don't saturate.  $C_1$  enhances stability.

**Figure 2** shows the necessary voltage for the circuit to begin operation. The output voltage (upper trace) has flatness at its lowest voltages as opposed to the input voltage (lower trace). **Figure 3** shows the two signals' linearity. Dividing the measured maximum of voltages  $V_1$  and  $V_2$  yields 0.91V. A test circuit uses an IL300, which has a gain of 0.851 to 0.955. The measurement meets the requirements of **Equation 11** despite the **equation's** simplifications. **EDN**

# Dark-activated switch needs only three components

Abel Raynus, Armitron International, Malden, MA

Assume that you have a device that receives its power from the main 120 or 220V-ac line and you need to add a switch between the ac line and the device so that the device works only when it is dark. Although you may think this task would be trivial, it is difficult to find a workable approach because most of the published schematics need 6 to 12V-dc power supplies and relays. Several off-the-shelf dark-activated switches, such as devices from Suns International ([www.suns-usa.com](http://www.suns-usa.com)), are available, but they're expensive for a consumer product. After looking at products from dozens of Web sites, you may decide to make your own. The solution is simple and inexpensive.

The circuit in **Figure 1** employs an internally triggered triac, which Teccor

Electronics ([www.teccor.com](http://www.teccor.com)) originally developed. The primary purpose of any triac is bidirectional-ac switching. The Quadrac triac has a built-in triggering device with the threshold-

voltage level of approximately 40V. To achieve this level, the circuit uses a voltage divider comprising a photocell and resistor  $R_1$ . When you light the photocell, its voltage drop is lower than the triggering level of the threshold voltage, and  $Q_1$  is locked, so the load disconnects from the ac line. When it becomes dark, the peak voltage amplitude on the photocell increases to 40V, opening  $Q_1$  and making the load connect to the power line.

The choice of  $Q_1$  depends on the load current and ac-line voltage. This circuit uses the Q4004LT from Littelfuse ([www.littelfuse.com](http://www.littelfuse.com)) with a maximum current of 4A rms and a voltage of 400V. You can use any photocell, but this circuit uses an off-the-shelf model and accordingly uses a value of 47 k $\Omega$  for  $R_1$  to achieve reliable switching. For an inductive load, add a 100 $\Omega$  resistor in series with a 0.1- $\mu$ F capacitor between pins 1 and 2 of  $Q_1$ . **EDN**

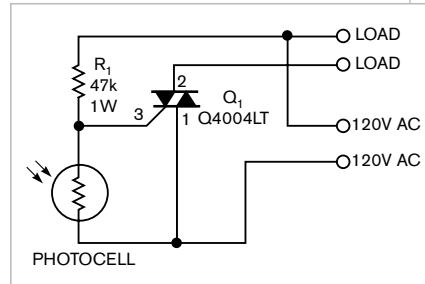

**Figure 1** This dark-activated switch needs only a photocell, a resistor, and a triac to switch between the ac line and the device.