

design ideas

Edited by Bill Travis and Anne Watson Swager

DDS device provides amplitude modulation

Mary McCarthy, Analog Devices, Limerick, Ireland

MANY APPLICATIONS REQUIRE an analog output to assume different amplitudes, but many direct-digital-synthesis (DDS) devices do not accommodate amplitude variations. Test equipment uses DDS devices to generate signals of different frequencies. However, the amplitude of these signals often must be variable, too. In communication systems, such as base stations, it is essential that the system does not deliver signals until data is ready to transmit. Between transmissions, the amplitude of the DDS-device output must decrease to near zero. In addition, many applications require AM. Some DDS devices have onboard amplitude registers that allow you to vary the magnitude of the analog output. However, you can also use DDS devices that do not have AM registers (**Figure 1**). The method involves varying the onboard DAC's current.

The onboard DAC for many DDS devices is a current-source type. The reference current to the DAC is a function of the reference voltage, V_{REF} , and an external resistor, which you normally tie from

the DAC to ground. The reference current is V_{REF}/R_{SET} . The full-scale current from the DAC is a multiple of the reference current; the multiple is a function of the size of the transistors in the DAC. For example, the full-scale current of an AD9830 is $16 \times V_{REF}/R_{SET}$. If you do not tie R_{SET} to ground but tie it instead to some varying voltage, V , the full-scale current is $16 \times (V_{REF} - V)/R_{SET}$. Varying V

varies the full-scale current and, therefore, the voltage output from the DDS device. You can provide the varying voltage by using a voltage-output DAC.

In **Figure 1**, an AD5310 provides a variable voltage to the AD9830. With the DAC output at 0V, the DDS device has maximum full-scale current. Increasing the voltage output from the AD5310 reduces the full-scale current of the AD-

Figure 1

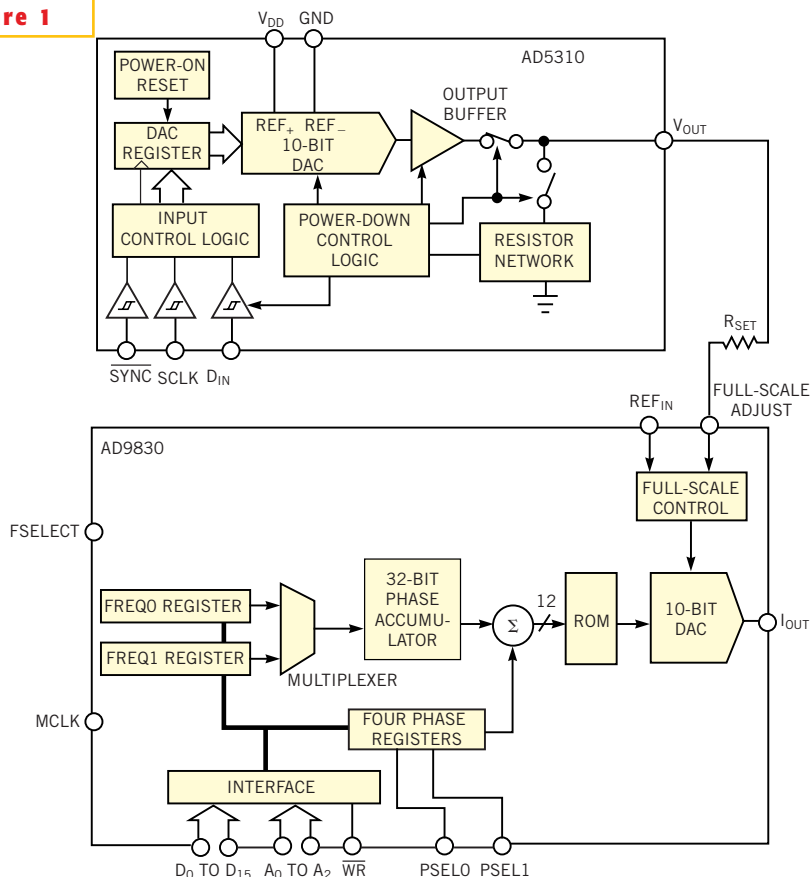

By using a voltage-output DAC, you can obtain amplitude modulation in a DDS device that does not provide for variable output voltages.

DDS device provides amplitude modulation.....	133
Charge pump converts V_{in} to $\pm V_{out}$	134
Electronic SPDT controls two PCs.....	136
GMR sensors manage batteries.....	138
Driver thermally compensates LED.....	140
Program turns PC sound card into a function generator.....	142
Li-ion battery charger adapts to different chemistries.....	146

9830. The AD9830 uses a 1-k Ω R_{SET} and a nominal V_{REF} of 1.21V, yielding a 19.36-mA full-scale current. **Figure 2** shows the output spectrum of the DDS device with this full-scale current. The master clock to the DDS device runs at 50 MHz, and the DDS device produces a 1-MHz output signal. The spurious-free dynamic range (SFDR) is typically 60 dB. Loading code 223 into the DAC generates a 1.089V output voltage. This voltage results in 1.936-mA full-scale current (reduced by a factor of 10) from the AD9830. With this full-scale current and the same clock and frequency conditions as above, the SFDR remains unchanged.

Figure 2

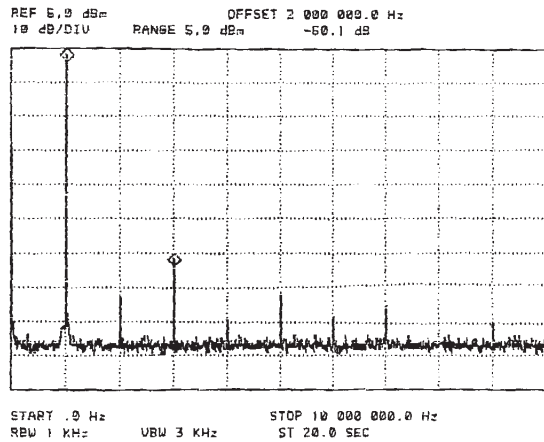

The spurious-free dynamic range for the amplitude-modulation system is 60 dB.

The AD5310 is a 10-bit DAC with integral nonlinearity of ± 2 LSB. It is suitable for use with the AD9830 in test equipment or for amplitude-ramping applications. If you need high-resolution amplitude modulation of the DDS device's output, you need a more accurate

DAC. The AD8300, for example, is a 12-bit DAC with integral nonlinearity of ± 2 LSB, representing a fourfold improvement over the AD5310. The increased accuracy makes this DAC more suitable for systems in which you need finer control

over the amplitude variations. Both DACs have a serial interface, so you need only three connections to talk to the DAC. (DI #2396).

TO VOTE FOR THIS DESIGN,
CIRCLE NO. 336

Charge pump converts V_{IN} to $\pm V_{OUT}$

Ioan Ciasci, Rei Data, Cluj-Napoca, Romania

A CHARGE-PUMP IC's ability to produce both V_{IN} and -V_{IN} outputs allows the circuit in

Figure 1

Figure 1 to generate separate positive and negative outputs from a single input voltage, regardless of the input-voltage polarity. For example, the circuit allows an RS-232C interface to generate a dual supply for low-power data-acquisition systems (if you use TxD as V_{IN}, and you limit V_{IN} to the ± 6 V maximum that IC₁ can accommodate). Consider a positive V_{IN}: The positive V_{OUT} appears via D₁ and supplies power to the IC via Pin 8. D₂ and R₁ pull Pin 7 high, which is a condition (along with other connections) for setting the chip in its inverter mode. As a result, the circuit produces -V_{OUT} at Pin 5.

For a negative V_{IN}, -V_{OUT} appears via D₃, D₂ and R₁ pull Pin 7 to ground, which, along with the Pin-5-to-Pin-6 connection, is a condition for setting the chip to its doubler mode. Thus, doubling -V_{IN} produces V_{OUT} at Pin 8. The MAX860 (or MAX861) operates at its minimum fre-

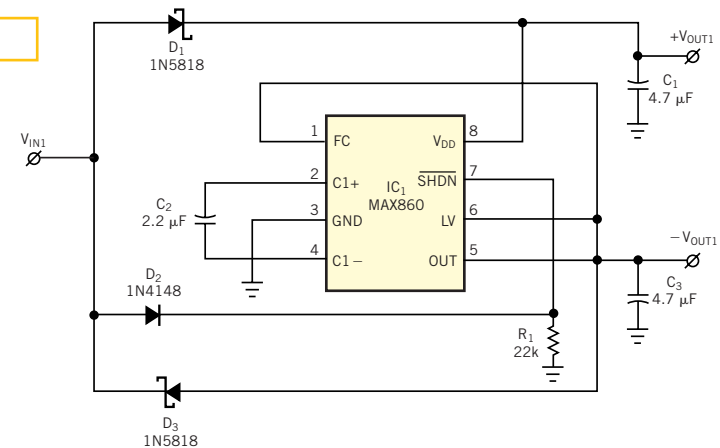

A charge-pump circuit produces simultaneous V_{OUT} and -V_{OUT} outputs when you drive it with either polarity of V_{IN}.

quency of 6 kHz (13 kHz for the MAX861) with Pin 1 unconnected and at its maximum frequency of 130 kHz (250 kHz for the MAX861) with Pin 1 connected to Pin 5. To reduce the voltage drops associated with D₁ and D₃, you can

replace the two Schottky diodes with MOSFETs. (DI #2402).

TO VOTE FOR THIS DESIGN,
CIRCLE NO. 337

Electronic SPDT controls two PCs

Luis Angulo, Barakaldo, Spain

THE CIRCUIT IN **Figure 1** is a switch that allows you to use one VGA monitor, one mouse, and one keyboard with two PCs. The switch has four pushbuttons. One switches the monitor between the two PCs, a second switches the mouse, a third switches the keyboard, and a fourth connects all devices to the PC that's inactive at the moment. The active portion of the circuit uses a PIC16F84 μC , IC₁, from Microchip Technology (www.microchip.com) and MAX395 (IC₂, IC₃, and IC₄) and MAX392 (IC₅) electronic switches from Maxim Integrated Systems (www.maxim.com). The μC is the core of the system; with a simple program, it checks the pushbuttons and selects the proper switches to implement the desired connection. You can download the program from EDN's Web site, www.ednmag.com. Click on "Search Databases/Links Page" and then enter the Software Center to download the file for Design Idea #2375. The μC also drives three LEDs that indicate the PC each peripheral connects to.

The circuit derives its power from the keyboard connector. If both PCs are initially off, and one switches on, the circuit connects all devices to that one. R₁ detects the switched-on PC and communicates the switched-on status to the RB2 input of IC₁. The circuit receives its power through D₁ and D₂. These diodes decrease the 5V supply by approximately 0.7V. The MAX682 step-up regulator, IC₆, restores the 5V for the more critical parts of the circuit. The MAX238, IC₇, provides TTL-to-RS-232C conversion and vice versa for the serial ports. The program initializes the μC 's registers and connects the devices to one of the computers, depending on the level at the RB2 input. It then executes a loop, which ends when you press a push-button.

The system detects the newly pressed key and changes the corresponding bit or bits of a register,

PC_SEL (PC Select) in the μC (**Table 1**). The routine then changes the signals, if necessary, to the MAX392, IC₅, for the

keyboard selection, and issues a group of bits to configure the MAX395s for the monitor and mouse control. Finally, be-

Figure 1

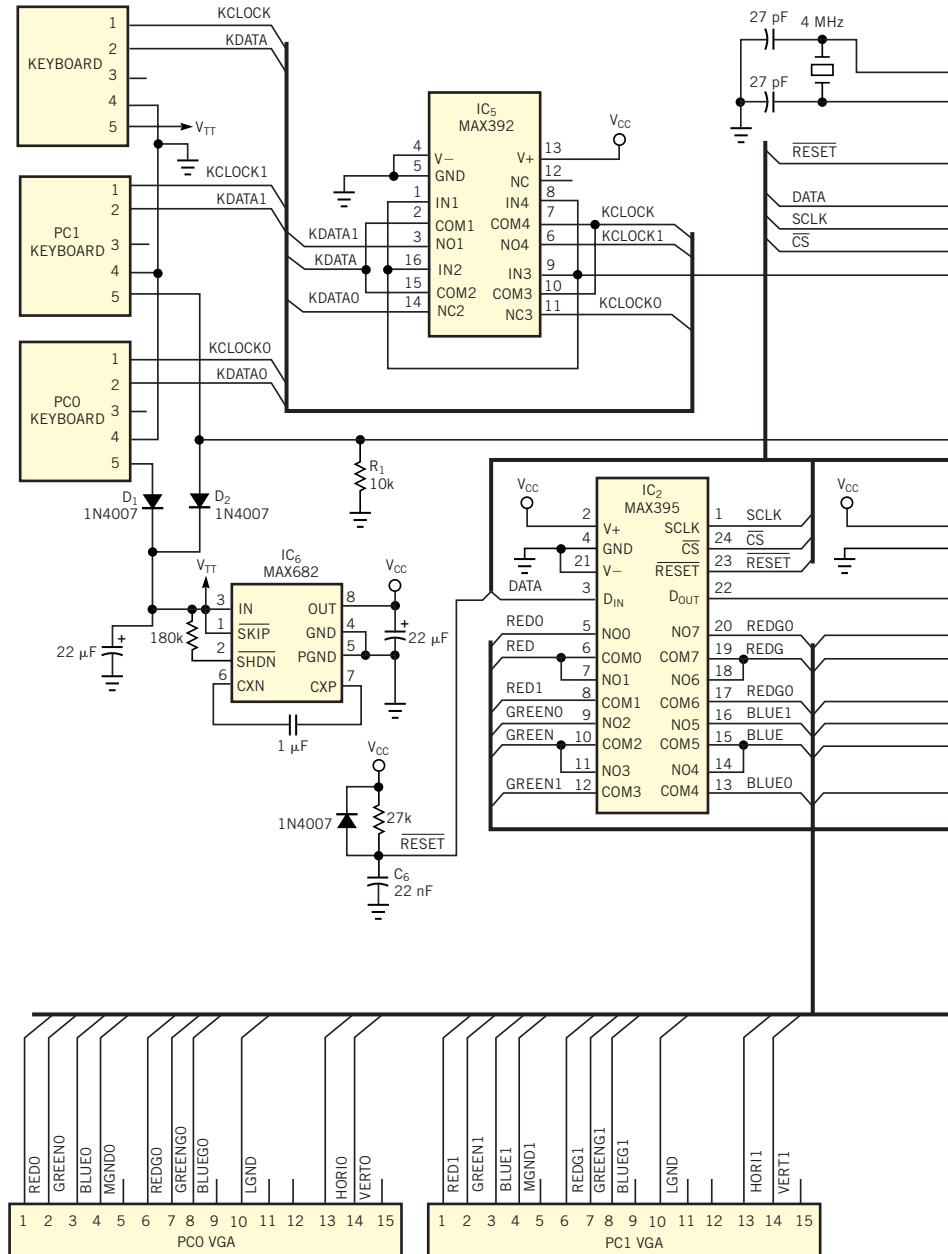

An electronic switch allows you to use a single monitor, mouse, and keyboard to control two PCs.

TABLE 1—PC_SEL REGISTER

Bit 7	Bit 6	Bit 5	Bit 4	Bit 3	Bit 2	Bit 1	Bit 0
Mouse	Keyboard						Monitor

fore returning to the main program loop, the software updates the LEDs, which in-

dicates which PC each device connects to. (DI #2375).

To VOTE FOR THIS DESIGN, CIRCLE NO. 338

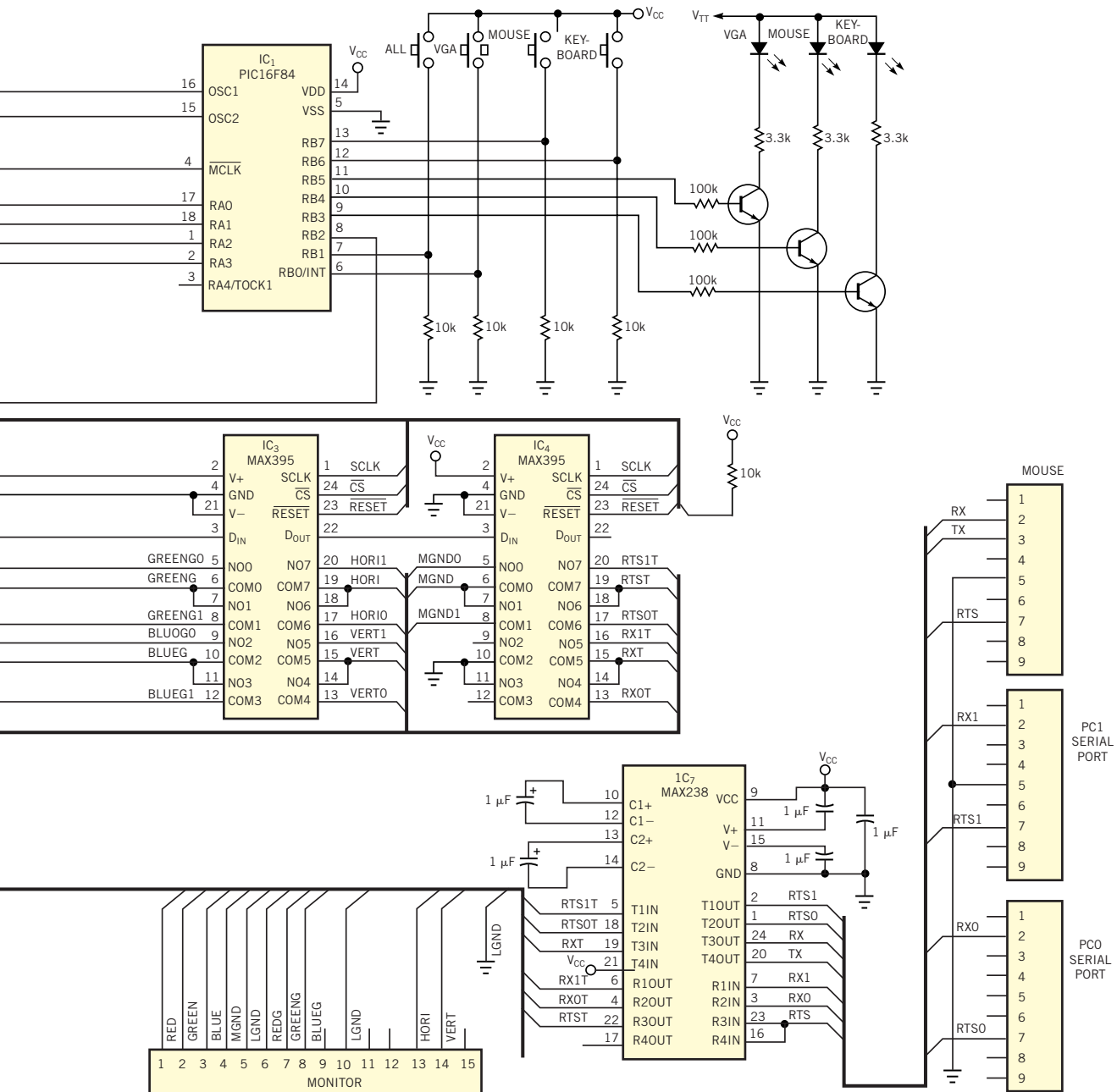

GMR sensors manage batteries

D Ramirez and J Pelegri, University of Valencia, Spain

THE PAST FEW decades have seen remarkable progress in magnetic-sensor technology. Early and current sensors exploit the Hall effect; more recent devices use an effect called giant magnetoresistance (GMR). GMR sensors use semiconductor processing of materials such as indium-antimony. The GMR sensor in **Figure 1** comprises four GMR resistors in a Wheatstone-bridge configuration. Two arms of the bridge have active resistors; the other two resistors are shielded against magnetic fields. When a magnetic field impinges on the sensor, the GMR effect decreases the resistance of the active pair of resistors, and the values of the shielded pair remain constant. GMR-based semiconductors are suitable for current measurement because they respond to the magnetic field rising from the current. However, in this application, the Wheatstone-bridge topology allows you to measure and control power.

All you need to do is connect the power pins of the GMR sensor to the voltage terminal, V+, and place the cable or trace the battery current traverses near the sensor. The output voltage of the bridge then relates to the power, which is the product of V+ and the current. The circuit in **Figure 1** provides a way to check a battery's condition. Measuring a battery's voltage is not the best way to check its condition; it's better to measure the power that the battery delivers in a discharge process to evaluate the battery's energy capacity and life. The circuit in **Figure 1** discharges a battery in a constant-power mode. You can select the level of discharge power. The GMR sensor's output signal is related to the discharge power. The power stage uses a bipolar Darlington transistor, which draws little power from its op-amp driver. You place the GMR sensor over the pc-board trace that connects the Darlington's emitter to ground.

Using the GMR sensor in a negative-feedback closed loop, the circuit controls the battery discharge in constant-power

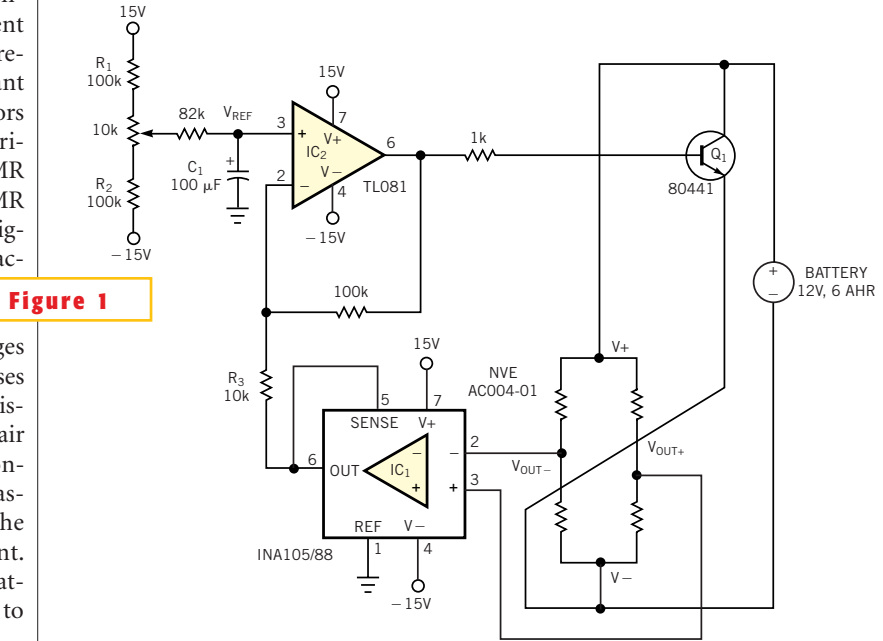
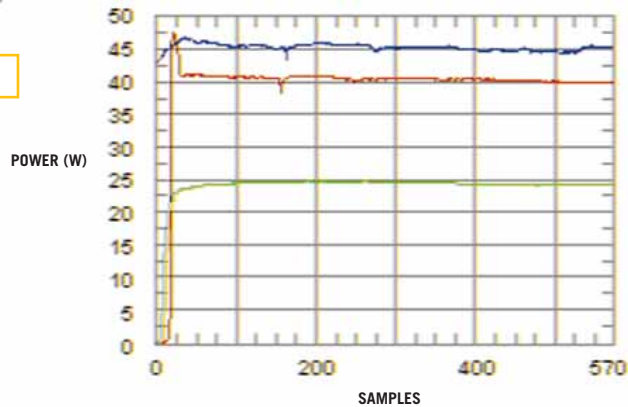

Figure 1

A GMR sensor and a closed-loop regulation circuit provide a constant-power discharge process for measuring a battery's energy capacity and life.

Figure 2



Sampling shows constant-power discharge profiles at 25, 40, and 45W for Figure 1's battery-management circuit.

mode. The difference amplifier (IC₁) converts the sensor's differential output signal to a unipolar signal; the op amp,

IC₂, supplies the appropriate loop gain and compares the difference-amplifier output with the externally selected ref-

reference voltage. IC₂ provides the base current for the Darlington transistor, which discharges the battery at a constant-power rate. **Figure 2** shows profiles of the constant-power battery discharge. **Figure 3** shows current, voltage, and power profiles of the constant-power discharge process. When the battery voltage decreases, the current discharge increases, and the power remains constant. (DI #2394).

Figure 3

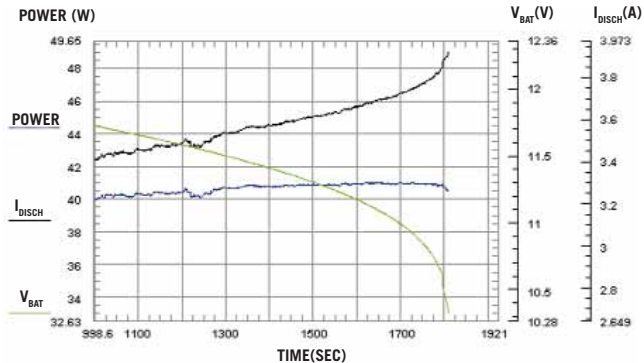

To provide constant-power discharge, the battery's voltage and current profiles have reciprocal, mirror-image slopes.

TO VOTE FOR THIS DESIGN,
CIRCLE NO. 339

Driver thermally compensates LED

Andrzej Wolczko, University of Mining and Metallurgy, Krakow, Poland

OPTICAL POWER OF popular types of LEDs decreases with temperature. Optical-power measurements into a typical multimode fiber at 62.5/125 μm for a GCA 1A194 LED indicate a temperature coefficient of approximately -0.4%/°C. In bipolar analog drivers for short- and medium-distance fiber links with a dc component, you frequently place an LED in the collector of a differential pair. For zero-input signals, the LED emits half its maximum power (zero reference), and the bipolar input signal modulates that power from zero to maximum. Temperature changes cause decreased power of zero reference and decreased slope efficiency of optical power versus input voltage.

The circuit in **Figure 1** allows you to compensate for both of these temperature-dependent problems, using only the TSF-102 sensor from Texas Instruments (www.ti.com). The device is a temperature-dependent positive-temperature-coefficient resistor with a linear temperature coefficient of approximately 0.7%/°C at 25°C. For the circuit in **Figure 1**, you must thermally couple the sensor with the LED. IC₂ is a summing amplifier for the input voltage and the reference voltage from IC₃. The gain is

Figure 1

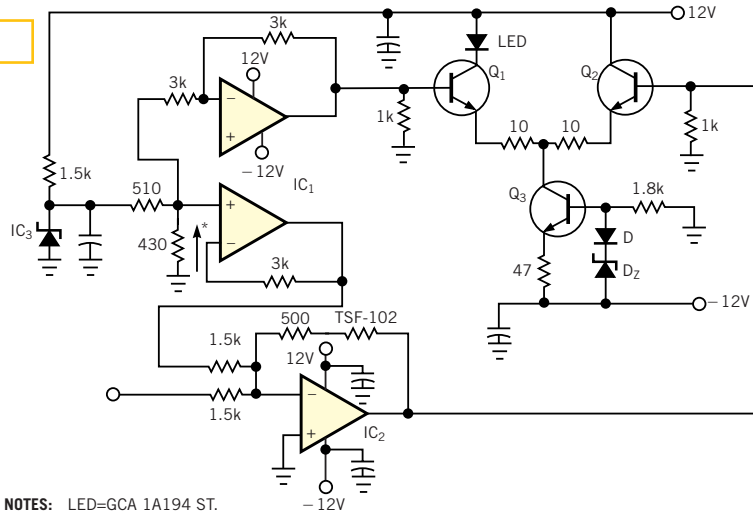

NOTES: LED=GCA 1A194 ST.
TSF-102=TI PTC SILICON SENSOR.
Q₁ THROUGH Q₃=BSX95.
IC₁=LM 158.
IC₂=HA 5020.
IC₃=TL431.
* REFERENCE VOLTAGE.
D=SI DIODE.
D_Z=5.6V ZENER.

A positive-temperature-coefficient sensor and a closed-loop amplifier circuit allow a LED to deliver constant optical power over temperature.

-1 and increases with temperature. The temperature-independent $-V_{REF}$ drives the base of transistor Q₂. The thermally stable current source, Q₃, via the differential pair Q₁-Q₂, supplies the LED. Note

that you should mount Q₃, D, and D_Z on a common heat sink.

With $V_{IN}=0V$, temperature changes unbalance the Q₁-Q₂ pair, such that the optical power remains constant. Empir-

ical measurements show that the compensation is optimal with $V_{REF} = 1.1V$. IC₂ amplifies the input signal by a temperature-dependent factor. You obtain matching of the temperature coefficient of the sensor to the coefficient of the LED by inserting the additional 500Ω resistor

in the feedback loop of IC₂. **Figure 2** shows the LED current (**Figure 2a**) and the optical power (**Figure 2b**) in the fiber-versus-input voltage for 10 and 50° C. The circuit provides an approximate tenfold decrease in the thermal coefficient. The improvement comes at the

cost of a limited input-signal range for linear operation. The circuit has a bandwidth of 0 Hz to more than 10 MHz. (DI #2398).

TO VOTE FOR THIS DESIGN,
CIRCLE NO. 340

Figure 2

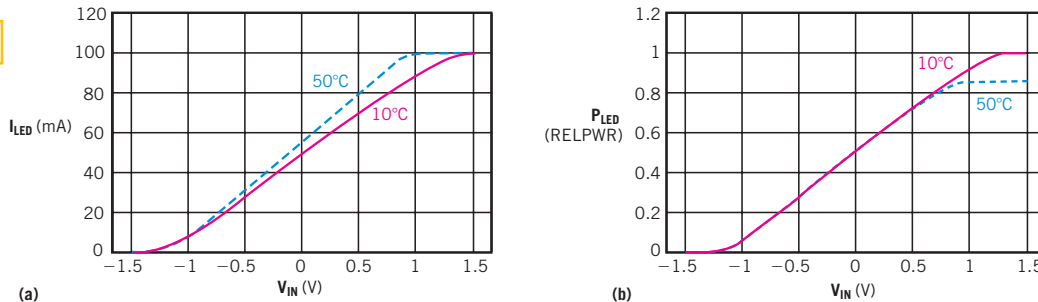

Using the circuit in Figure 1, an LED uses temperature-dependent operating current (a) to produce nearly constant optical power (b) at 10 and 50°C.

Program turns PC sound card into a function generator

David Sherman, David Sherman Engineering Co, Everett, WA

YOU CAN USE a low-cost PC sound card as an analog-function generator by controlling the PC with the program “SoundArb.” The program generates standard waveforms, noise, and arbitrary waveforms. The program reads arbitrary waveforms from simple ASCII text files consisting of white-space-separated numbers. You can use a program such as Mathcad to create such files. SoundArb provides common triggering modes, such as continuous, one-shot, burst, and toggled. An on-screen “button” serves as the trigger input. The program’s user interface is a dialogue-box-style control-panel window. (You can download the self-extracting installation program from EDN’s Web site, www.ednmag.com. Click on “Search Databases” and then enter the Software Center to download the file for Design Idea #2409.)

The main advantages of using a

sound card as a standard and arbitrary waveform generator is its low cost and ready availability. The typical 16-bit resolution is better than many arbitrary-waveform generators, the output drive capability is generally good, and you can’t

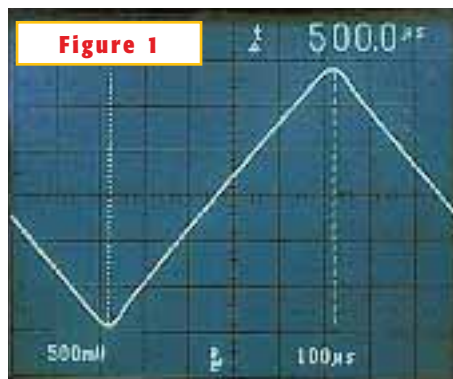

Using a cheap sound card, the SoundArb program produces a 1-kHz triangle wave. Limited high-frequency bandwidth produces the rounding at the points of the triangle wave.

beat the price: as low as \$10.

The disadvantages include poor waveform quality, including distortion, noise, and ringing; ac-coupled output only; limited triggering modes, including no external trigger; imprecise amplitude adjustment; and the possibility of interruptions in the waveform due to other system demands. All in all, the quality of the generated waveforms depends directly on the quality of the sound card, and the cheapest cards generate the worst waveforms. An oscilloscope photo (**Figure 1**) shows a 1-kHz triangle wave such as those generated by cheap sound cards. The photo shows rounding of the points of the triangle wave due to limited high-frequency bandwidth.

SoundArb is a 32-bit application that runs under 32-bit Windows. The program communicates with the sound card through the Windows multimedia application-program-

ming interface, so it should work with most sound cards. SoundArb places relatively light demands on the system, so a fast CPU and large amounts of memory are usually unnecessary. Long arbitrary waveforms may require more memory. Low-cost sound cards rely on the computer's main memory for waveform storage, which means that, if the system is slow or busy, the waveform may be interrupted. The sound card must support the pulse-code-modulation, audio-wave format; must have 16 bits of resolution; and must have a maximum sample rate of at least 44.1 kHz. Although standard sample rates are 10.25, 20.5, and 44.1 kHz, many sound cards support any integer sample rate within a much wider range. Such a card is a more versatile function generator than one that supports only the standard sample rates.

The resolution and full-scale range of the amplitude adjustment depend on the design of the sound card. Unfortunately, no way exists to set the amplitude to a known voltage other than by observing the waveform on an oscilloscope. Many sound cards have relatively few amplitude levels, and these levels do not necessarily follow either linear or logarithmic curves. One card tested provided 16 amplitude steps, including "zero." The remaining 15 steps followed a two-part piecewise-logarithmic curve.

If you have a stereo sound card, SoundArb allows you to use the "right" channel as a "sync" output to mark the start of the analog waveform. Note that a sound card reproduces only audio frequencies. Most provide no dc-coupled output. The output bandwidth typically approximates the 20 Hz to 20 kHz audio band. A good first test of your sound card is to generate square waves of various frequencies and lengths while monitoring the output with an oscilloscope. Low-frequency square waves may show a pronounced droop due to an ac-coupled output, and ringing on the edges may be severe. The amplitude and frequency of the ringing may depend more on the sample rate than on the waveform repetition rate. Much of this depends upon the analog-to-digital-conversion technique that the sound card uses. Take the

time to familiarize yourself with the analog limitations of your sound card before relying upon it for important work. For more information on this, search the online help index for the keyword "Distortion."

To use the sound card for electronic testing, you probably need to make an adapter cable (**Figure 2**). A convenient way to make the cable is to obtain two male BNC-to-cable connectors, a stereo miniphone plug, and a short shielded wire. Because of the low frequencies involved, you need no coaxial cable. You then connect your normal BNC-to-clip-lead test cables to the male BNCs. Alternatively, you can make a longer cable by terminating the right channel in a female BNC, which you can connect to the sync input of your oscilloscope. You can terminate the left channel in an alligator clip or a minigrabber. If you don't use the

Grounding may be less than optimum because no good way exists to connect the PC's ground to the ground of the device under test. If glitches from the sync line are a problem, you may be able to disconnect that line's shield from its BNC shell, assuming that the waveform line's shield remains connected to its BNC's shell. If necessary, you can break a bad ground loop by isolating, or floating, the PC and its monitor from the power-line ground. You cannot use a "cheater" plug because it defeats the safety aspects of grounding and can allow the PC chassis and peripherals to become hot. To isolate the PC from the power line and its ground, use a medical-grade isolation transformer that includes a Faraday shield between the primary and secondary windings. This transformer often reduces interference from noisy power lines and may reduce conducted EMI, es-

Figure 2

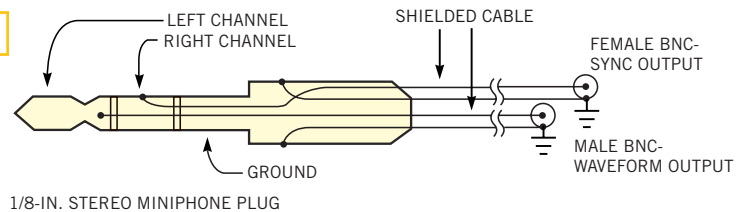

A convenient adapter cable comprises two male BNC-to-cable connectors, a stereo miniphone plug, and a short length of shielded wire.

right-channel sync output, you can get by with one BNC and one piece of cable because the program supports only "right-channel-sync" mode. The tip of the miniphone plug carries the left-channel signal, the first ring carries the right-channel signal, and the main ring provides the ground. Separate shielded cables, rather than a shielded twisted pair, between each BNC and the phone plug are recommended because with the twisted pair the sync pulse edges capacitively couple into the waveform and cause glitches. As an alternative to using a miniphone plug, most sound cards have an internal waveform output comprising a pin header on the card. Some cards also have jumpers that you can use to select between "line out" and "speaker out," the difference being the output impedance or voltage.

pecially if used with an RF-line-filter block.

Never float the PC or any other test equipment as a way to connect the ground to a high voltage, for example, to connect an oscilloscope probe across a current-sensing resistor in a hot ac power line. Doing so could kill you, and you could destroy expensive test equipment whose power supply was not designed for a ground-to-neutral voltage of more than 30V. If you need to connect test equipment to a high voltage, use optical or magnetic isolation in the signal wires, not in the equipment's power supply. Small, modular isolation amplifiers with low distortion are readily available at reasonable prices. (DI #2409)

TO VOTE FOR THIS DESIGN,
CIRCLE No. 341

Li-ion battery charger adapts to different chemistries

Fran Hoffart, Linear Technology Corp, Milpitas, CA

RECHARGEABLE LITHIUM-ION (Li-ion) cells require a precise charging voltage for maximum performance. The battery chemistry, of which there are many, determines the optimum charge voltage. Two of the more common charging voltages are $4.1V \pm 50$ mV and $4.2V \pm 50$ mV per cell.

Consider the following situation: You have thousands of three-cell Li-ion battery chargers with an output voltage of $12.6V \pm 1\%$. However, because of a battery-chemistry change, your chargers now need $12.3V \pm 1\%$. The $12.6V$ output is well-regulated and has current limiting, but the voltage is 300 mV too high, and you cannot easily adjust it.

The circuit in **Figure 1** can solve this problem by providing a constant 300-mV drop between V_{IN} and V_{OUT} at currents as high as 3A. The accuracy of the 300-mV drop is nearly as good as the accuracy of the input voltage, which in this case is approximately 1%. This circuit re-

quires an input voltage that is fixed, regulated, and preferably current-limited. A precision voltage divider across the regulated input derives the 300 mV necessary for the circuit to operate, thus eliminating the need for an external voltage reference. The circuit also includes a logic-level low-quiescent-current shutdown. In shutdown, the series MOSFET, Q_1 , is off, and the total circuit current drops to approximately 8 μ A.

The circuit operates by developing a 300-mV reference voltage across R_1 and applying this voltage to the inverting input of the op amp. The noninverting input connects to the output side of the p-channel MOSFET. The resultant feedback loop forces the voltage across Q_1 to equal the voltage across R_1 , which is 300 mV. In normal operation, the voltage drop across R_1 and Q_1 are equal in value but opposite in polarity, thus forcing the voltage between the two op-amp inputs to be 0V. C_1 provides stability, and

C_2 and C_3 bypass the supply.

Although this circuit was intended to solve a Li-ion-charger problem, you can use the circuit for any application that needs to drop a constant voltage. Changing the appropriate resistor values allows the circuit to accommodate other input voltages or voltage drops. The voltage drop across R_1 determines the voltage drop between V_{IN} and V_{OUT} . For low input voltages of 5V, reduce R_2 to 470 Ω to ensure adequate gate drive for Q_1 . Q_1 has a low $R_{DS(ON)}$ and comes in an SO-8 surface-mount package. Allow a minimum of 1 sq in. of pc-board copper around the eight leads for heat sinking. Higher voltage drops require additional copper area. For even higher power levels or higher currents, select a MOSFET in a TO-220 package and mount it to an appropriate heat sink. (DI #2408)

TO VOTE FOR THIS DESIGN,
CIRCLE NO. 342

Figure 1

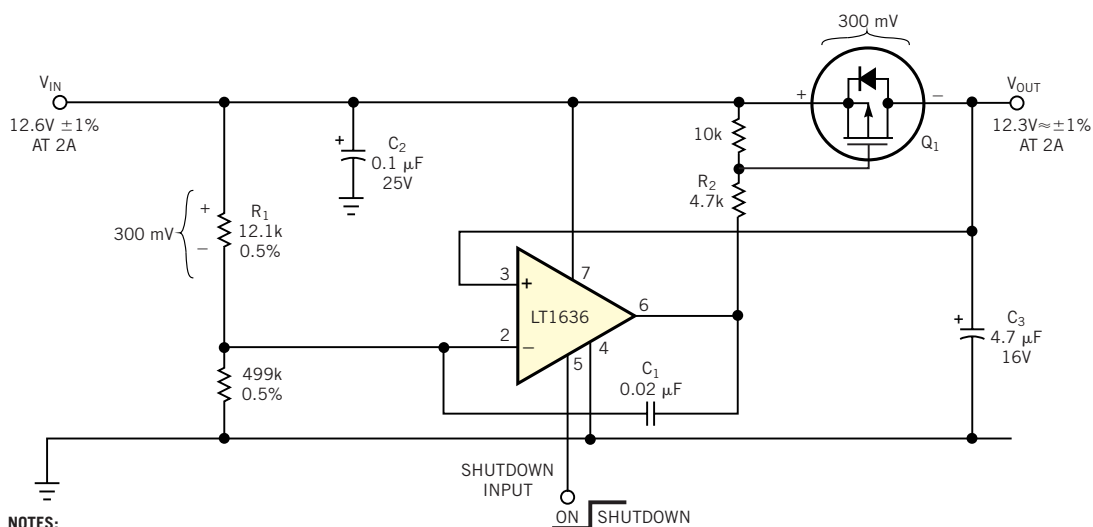

NOTES:
 Q_1 =35-m Ω P-CHANNEL MOSFET, Si4435 (SILICONIX).
SCHEMATIC SHOWS BODY DIODE.

A feedback loop comprising the op amp and Q_1 produces a constant voltage drop between V_{IN} and V_{OUT} , thereby providing a low-voltage, series-zener type of function.

Design Idea Entry Blank

Entry blank must accompany all entries. \$100 Cash Award for all published Design Ideas. An additional \$100 Cash Award for the winning design of each issue, determined by vote of readers. Additional \$1500 Cash Award for annual Grand Prize Design, selected among biweekly winners by vote of editors.

To: Design Ideas Editor, EDN Magazine
275 Washington St, Newton, MA 02158

I hereby submit my Design Ideas entry.

Name _____

Title _____

Phone _____

E-mail _____ Fax _____

Company _____

Address _____

Country _____ ZIP _____

Design Idea Title _____

Social Security Number _____
(US authors only)

Entry blank must accompany all entries. (A separate entry blank for each author must accompany every entry.) Design entered must be submitted exclusively to *EDN*, must not be patented, and must have no patent pending. Design must be original with author(s), must not have been previously published (limited-distribution house organs excepted), and must have been constructed and tested. Fully annotate all circuit diagrams. Please submit software listings and all other computer-readable documentation on a IBM PC disk in plain ASCII.

Exclusive publishing rights remain with Cahners Publishing Co unless entry is returned to author, or editor gives written permission for publication elsewhere.

In submitting my entry, I agree to abide by the rules of the Design Ideas Program.

Signed _____

Date _____

Your vote determines this issue's winner. Vote now, by circling the appropriate number on the reader inquiry card.