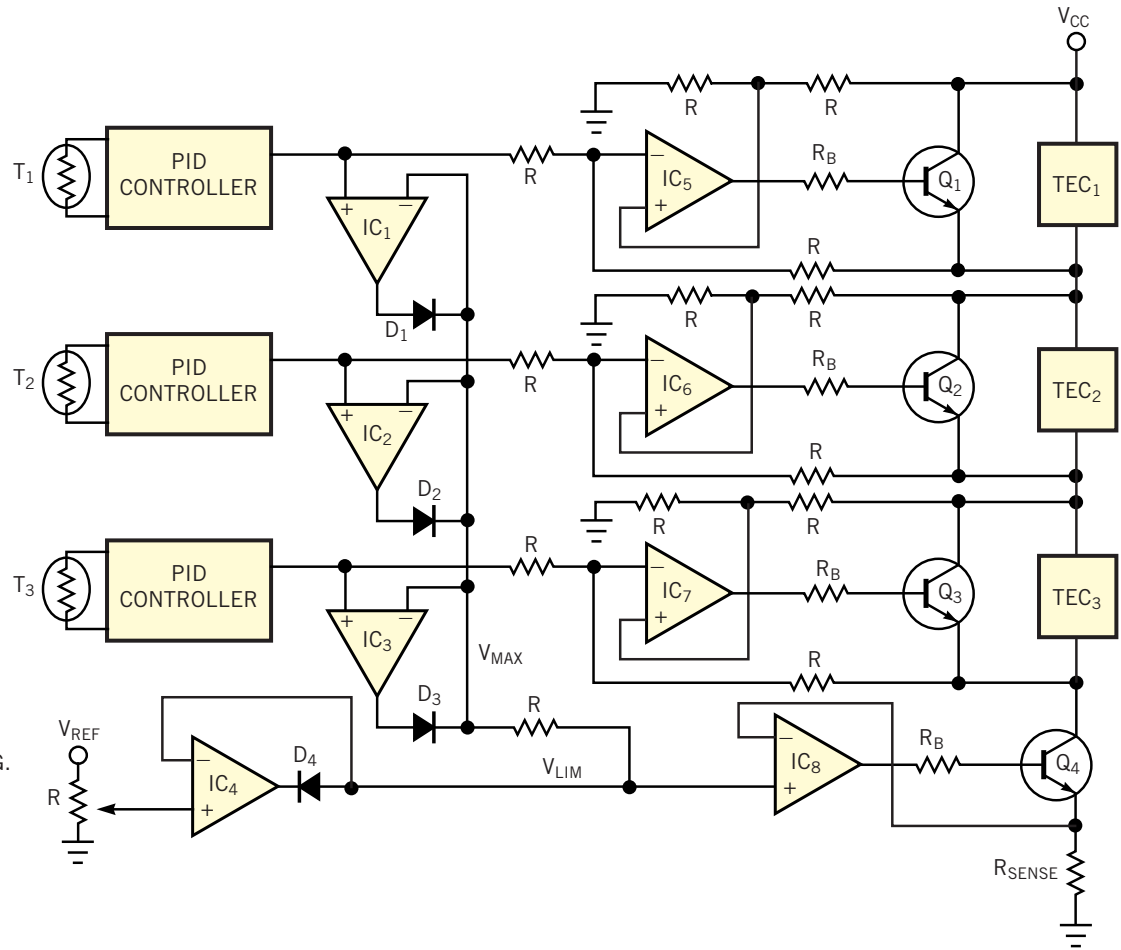

**Figure 1**



**NOTES:**

$R=10\text{ k}\Omega$ ,  $R_B=1\text{ k}\Omega$ ,  $R_{SENSE}=1\Omega$ .

IC<sub>1</sub> THROUGH IC<sub>8</sub>= $\frac{1}{4}$  TLO84 QUAD OP AMP.

Q<sub>1</sub> THROUGH Q<sub>4</sub>=TIP120 DARLINGTON TRANSISTOR.

D<sub>1</sub> THROUGH D<sub>4</sub>=1N914.

T<sub>1</sub> THROUGH T<sub>3</sub>=10k AT 20°C.

TEC<sub>1</sub> THROUGH TEC<sub>3</sub>=1A AT 1V FULL RATING.

PID BLOCK IS A GENERIC RESISTANCE-INPUT AND VOLTAGE-OUTPUT ANALOG CONTROL CIRCUIT.

**A series connection of thermoelectric coolers provides more efficient temperature control and fewer supply-current requirements than circuits using individual cooler controllers.**